

# SURVEYING INSTRUMENTS

---

**Heller & Brightly**  
Philadelphia

# SURVEYING INSTRUMENTS

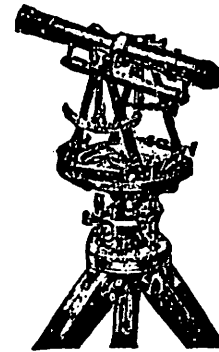

Heller & Brightly

Philadelphia

APR 26 1920

**M**akers of  
Accurate Surveying  
Instruments  
for Nearly  
Half a Century

## Foreword

---

**E**VERY little while the world, for a fleeting moment, stands awed by the wonderful accomplishments of engineering. Its canals, its railroads, its bridges are monuments to success. Monuments to a thousand and one men,—specialists who have added their “mite”—performed their duty.

Manufacturers of surveying instruments, in their way, share in the final reckoning, too. And indeed their part is no small one. Men live and die, perfecting with infinite care the hair-breadth adjustments of these instruments—spending hours to check the ten-thousandth part of an inch—developing machines of unimaginable accuracy to attain such perfection.

And so for nearly fifty years, during which time instrument makers have come and gone, Heller & Brightly have lived up to an ideal—a pride in accuracy and design, well established by the faithful ones who have gone before, well upheld by those who have inherited this legacy.

On such principles H. & B. instruments are built—on such principles their success has been and is, we believe, assured.

**Heller & Brightly**

## TABLE OF CONTENTS.

	PAGE
CHARACTERISTICS OF A GOOD SURVEYING INSTRUMENT.....	5
Transit .....	5
Mining Transit .....	10
Tunnel Transit .....	11
Leveling Instrument .....	12
Telescopes .....	15
Surveyors' Compass .....	17
Solar Transit and Compass.....	25
IMPROVEMENTS IN DESIGN OF TRANSITS:	
J. Peter Lesley's Paper.....	30
Franklin Institute Report.....	35
MINING TRANSIT AND PLUMMET LAMP.....	39
MINE SURVEYING INSTRUMENTS—BENJAMIN SMITH LYMAN.....	43
IMPROVED METHOD OF MEASURING IN MINE SURVEYS.....	47
SUN-FLOWER TUNNEL CROSS-SECTIONER.....	52
HELLER & BRIGHTLY SURVEYING INSTRUMENTS:	
Commentary .....	65
General Characteristics—Constructional Features .....	66
Stock Features .....	68
PARTS OF H. & B. INSTRUMENTS.....	70
TRANSITS:	
Large Complete Combined Transit and Leveling Instrument..	75
Intermediate Complete Combined Transit and Leveling In-	
strument .....	79
Small Mining and Reconnaissance Transit.....	82
Tunnel Transit .....	83
Solar Transit .....	83
SUNFLOWER .....	83
PLANE TABLE .....	83
EXTRAS TO LARGE, INTERMEDIATE AND SMALL TRANSITS.....	85
WYE-LEVELS. IMPROVED 18" LEVELING INSTRUMENT.....	87
Small Mining and Reconnaissance Level.....	87
Parts of H. & B. Levels.....	88
Extras to Wye-Levels.....	89
WEIGHTS OF H. & B. TRANSITS AND LEVELS.....	89
GENERAL SPECIFICATIONS .....	89
REPAIR PARTS LIABLE TO ACCIDENT OR LOSS.....	89
WHAT MANY WELL KNOWN ENGINEERS THINK OF H. & B. IN-	
STRUMENTS .....	93
COLLEGES AND UNIVERSITIES USING H. & B. INSTRUMENTS.....	110
INFORMATION TO PURCHASERS.....	113
TABLE OF EXPRESS CHARGES.....	116
LEVELING RODS AND POLES.....	118
COMPASSES AND CHAINS.....	118
STEEL AND METALLIC TAPES.....	120
DRAWING INSTRUMENTS, SUPPLIES, ETC.....	120

## REMARKS ON ENGINEERS' SURVEYING INSTRUMENTS.

### Characteristics of Good Instruments—and Their Defects.

We are often applied to by Engineers respecting the methods to be employed in testing the accuracy of the various parts of Engineers' Instruments, the errors to which they are liable, and the means of correction. These queries are, however, mostly from those just commencing practice, their elder brethren, as a general rule, knowing how to make an instrument "prove itself."

In the following articles we have endeavored to comply with these requests. It would surprise those who think "one instrument as good as another" to be informed that in perhaps no other branch of mechanism are palpable "errors of omission and commission" more common than in ours—surveys extending over months of time have been rendered almost useless from "instrumental error," and a considerable portion of the business of our courts of law is caused directly and indirectly by imperfections of instruments.

The recent case of the City of Burlington, N. J., is in point. Here the courts were so frequently annoyed by land suits from defective surveys that the Legislature of the State was compelled to pass a law that an entire re-survey, by a competent person and first-class instruments, should be made. A law requiring every instrument to be tested and proved by a competent person (not necessarily a manufacturer) would have a tendency to weed out instruments which, like "Peter Pindar's" razors, are made, "not to use, but to sell."

We will not stop to speak of the ordinary adjustments of instruments, as they are found in every elementary work pertaining to Civil Engineering—if a knowledge of these, however, be required, "Trautwine's Engineers' Pocket-book" will give them in detail. We will mention in their order, the Transit, Level, Telescope, Compass, and Solar Compass.

### The Transit.

A first-class Transit Instrument should possess the following qualities:

I. **Graduations.** These should all be on silver plate, instead of on the plain brass, silver-washed, as is usual. All astronomical instruments are done in this way, as a smoother, truer graduation can be had. The divisions of the horizontal limb should be truly graduated and centred, *i. e.*, the graduations should be *precisely* the same distance from each other—the centre of the graduations and the centre of revolution should be *precisely* at the same point.

2. **Verniers.** The instrument should always have two opposite verniers to the horizontal limb, and these verniers should be equally spaced. In astronomical instruments more than two verniers are absolutely necessary, but we are now speaking of Engineering Instruments. The openings and windows in the upper plate for reading the verniers of the horizontal limb should be as wide as possible, to admit light freely upon the verniers and plate, thus facilitating an accurate reading (this single point as a general rule being overlooked).

3. **Level Tubes.** The interior of the glass level tubes should be ground, in order that their bubbles may act correctly. Very cheap bubbles are made by bending a cylindrical glass tube.

4. **Needle.** The needle should be sensitive enough to coincide with the verniers of the horizontal limb without disagreeing more than 3'.

5. **Centres.** The centre upon which the vernier plate turns, and the common centre upon which the entire instrument revolves (we are now having one of the best class of Transits under consideration—*i. e.*, *one with long compound centres*), should be concentric with each other, and the levels, if adjusted to one centre, should reverse upon either one at will. Both of the centres should be always covered, and not detachable from the main plates. The plates and centres should move smoothly in all temperatures. The spindle of a turning lathe can never be made precisely round, and of course any article turned in a lathe can only be as true as its spindle. Any work that is required to be precisely round and true, such as the journals of the axes of an Astronomical Transit or its centres, is turned on a lathe in which the spindle remains stationary, and the work revolves between centres. In order to insure actual truth of the centres of all of our instruments they are made by this method (termed turning between "dead centres"), although it has heretofore only been used for astronomers' instruments.

6. **Tripod.** The tripod and tripod head should be firm and steady, the centre of gravity of the instrument should be brought as near to the tripod head as possible, and the instrument should not be top-heavy. The tripod should be furnished with an adjustable tripod head for precise centering of the instrument. The adjustable tripod head is intended for precisely centering the instrument, after approximately setting by the legs in the following manner: First set the instrument approximately by the legs to within an inch or less, loosen two of the leveling screws, then move the entire instrument until the plummet is precisely centred. While placing the instrument level by means of the leveling screws it is again clamped.

7. **Leveling Screws.** The leveling screws should have deep threads, good milled finger-heads, and be well fitted to their nuts. The tangent screws should move smoothly and have no "back lash."

8. **Vertical Arc.** The vertical arc or circle (if one is used) should have a diameter of not less than  $4\frac{1}{2}$  inches, to allow single minutes (at least) to be read easily.

9. **Telescope.** The telescope should be balanced in its axis. Its length is made from 10 to 12 inches, to allow of its reversing in its standards, both at eye and object ends; it should have power enough to set an ordinary flagpole at 1000 feet; its object glass slide should move in and out in a perfectly straight line, in order that the line of collimation, when adjusted for a long distance, shall be correct for short distances. This precaution does not always receive the attention it should, and young Engineers are frequently at a loss to account for discrepancies in their observations which are due to this cause. The slide of the object glass should be long enough to be able to focus an object five feet from the instrument.

10. **Adjustments.** The adjustments of the telescope (and in fact of the whole instrument) should be as few as possible, every part admitting of it to be made as permanent as practicable. One end of the axis of the telescope should be adjustable, so as to make the "line of collimation" revolve truly in a vertical plane; and this adjustment should be provided with a jam nut, in order to fasten it securely after adjustment. Remember also that the necessarily experienced frequent adjustment of an instrument, more especially of the cross wires, is due not so much to use as to the common error of supposing that the tighter screws are forced, the firmer and more lasting will be the adjustment. On the contrary, something must be strained, and every change of temperature is then more liable to alter the adjustment. The adjusting levers should be rather short than otherwise (say about  $1\frac{1}{2}$  inches)—inasmuch as by using a long one too much force may be inadvertently applied, and thus either snap a screw or overstrain some more delicate part of the instrument; in fact, a brass wire would perhaps make the best adjusting pin, as it would bend if undue pressure were applied. The mechanical construction should be so arranged that all the parts shall as far as possible brace each other.

**Defects.** Having mentioned the traits a good transit should possess, we will pass in review some of the more common defects; and in this connection will take the opportunity of remarking that all the defects we will enumerate are matters of almost every-day observation in establishments that have a large amount of outside repairing to do. As the Telescope has been termed "the brain; and the graduations the soul of a Transit," we will first take imperfect graduation, as this is the most serious and damaging imperfection, and one of the most difficult to avoid in practice, as any of the following causes may defeat it during the process of construction. This may be due to an imperfect graduating engine, defective centering, or an unstable cutting arrangement; and, even if all these be correct, in the very act of graduating, the plate may shift on the engine, from change of temperature; or the clamps, metal of the plate, or engine, may expand unequally from the same cause. In fact, the manufacturer, with all the care he may take, is not sure himself whether the process of graduating a plate has proceeded correctly until the graduations themselves are proved by means of its own opposite verniers, and until "testing reversions," for the purpose of proving the centre and graduations, have been taken on all parts of

the circle. The "fertile principle of reversion" and its peculiar merit of "doubling the real error, thus making it twice as easy to perceive" here, as in every other adjustment of the instrument, makes each part prove itself. It was mentioned among the points of a good transit that the horizontal limb should have two opposite verniers. Without these even the manufacturer himself cannot (as explained above) be sure of the accuracy of his graduations; however, by taking a mean of two opposite readings, reversing and repeating, an accurate angle can be taken even though there be an imperfect graduation.

**Personal errors.** One very rare cause of observation may be mentioned in speaking of the reading and testing of graduations. We refer to those persons who, probably from some defect of the humors of the eye (not from advancing age), are unable to read a vernier correctly. Extreme cases of this "personal aberration" are fortunately rarely met with; the writer in fifteen years' intercourse with hundreds of Engineers has only met with two; in both of these, if a reading was taken and noted by them, the vernier might be shifted two minutes to the right or left, and these parties could perceive no change in the reading,—and in their field operations close readings of graduations had to be taken by assistants. We do not here refer to the "difference of reading" of two persons, which under the term of "personal equation" is calculated and allowed for in refined astronomical observations. To show that this "personal equation" is inborn and not the result of inexperience, we may mention the cases of the two celebrated astronomical observers Bessel and Struve, between whom at one period of their lives amounted to .8 of a second, and a later period to a full second.

**Use of one or both verniers.** If the Engineer is satisfied that his graduations are correct, he need read but one of his verniers, rendering the window of the opposite one opaque (to prevent mistake by reading the wrong vernier) by dulling it with oil, or pasting a wafer on it. It is a good method, where two verniers are used, to have some mode of designating them apart; our own mode is to engrave the letter A upon one, B upon the other. The numbering of the degrees may be done in several ways; our own method is to place on both the horizontal limb and needle ring two rows, one behind the other, and each row of a different sized figure, to prevent mistakes; one row in quadrants ( $0^{\circ}$  to  $90^{\circ}$  each way), and the other a continuous one or from  $0^{\circ}$  to  $360^{\circ}$ .

**Transit with one vernier.** What are known in the trade as Surveyors' Transits (a form which we never make), and sold cheaper than the regular Engineers' instruments, have but one vernier. The centres, etc., of this class of instrument are not of a construction to admit of, or made as a general rule accurate enough to allow of double verniers, and of course great accuracy cannot be attained with such instruments. Those who purchase an instrument will find it the best policy to procure one accurate enough for the best work they may ever be called upon to do, but only to work up to the full accuracy of their instrument when the character of the work may require it. As to the amount of error of graduation found in the ordinary run of instruments, it ranges from one

to five minutes;\* some exceptional cases going even beyond this; but these latter were evidently caused by some disarrangement of the graduating engine, and could not have been overlooked had the instruments had opposite verniers. As a minute of arc causes an error of over 18 inches in a distance of a mile, in no case should the error of graduation be allowed to reach a minute. It is best in reading the graduations to hold the magnifier as near parallel over the graduations as possible, move the head slightly and notice whether the graduations seem to move; if they do, parallax is the cause; raise or lower the magnifier until no movement is seen. It is best not to use a magnifier with too high a power; one from two to three inches focal length is sufficiently powerful for general use.

**Spacing of the verniers.** This should be exact—that is, in a minute vernier (reading a half degree plate) they should be precisely 2) apart. One common error in verniers is that the lines are not spaced equal, i. e., some are  $28' 30''$ , others  $28' 45''$  apart. One of the easiest methods to prove their freedom from this defect is by setting the half-way line ( $15'$ ) to cut a line on the horizontal limb; then the other three  $15'$  marks must cut—presuming that the verniers are double, and opposite, properly adjusted, and the horizontal limb is truly graduated. Our own practice in adjusting Transits is to test our horizontal limb with powerful microscopes, by opposite readings and "repeating reversions" on every part of the circle.

**Travelling.** It also serves to keep the instrument in better order if the tripod head, with its levelling screws, can be detached and packed away with the instrument proper. In travelling, the tripod should have a cap to its head, and a ring or strap to confine the legs. The adjustments will keep better if four india-rubber washers are screwed at the corners of the bottom of the box, as these washers often absorb shocks and prevent their reaching the instrument with so much force. A common error is to place leather washers under the levelling-screws. This should never be done, especially on a Levelling instrument, the leather being affected both by the weather and by the pressure of the ends of the screws. It is almost impossible for an instrument with such leathers to retain precisely the same line of sight even for a few moments.

**Metal used.** The brass of which the instrument is made should not be ordinary yellow brass, for several reasons—first, because the brass as it comes from the melting-pot is too soft for use, and requires to be condensed with a hammer; and this hammering can never be so equally done but that some parts will be more condensed than others, and unequal expansion and contraction, and hence derangements of adjustment at every change of temperature, are the results; second, the zinc which is a prominent part of the alloy of yellow brass will in time by mere atmospheric exposure change the texture of the metal, so as to

\* Much dissatisfaction with these instruments (Engineers' Transits) was expressed by the assistants; their objections were these,—first, an eccentricity or imperfection of graduation of two minutes, more rarely three minutes, was frequently found in the reading of the verniers of the horizontal limbs, etc.—Extract from Report of Chief of Engineers, U. S. A., to the Sec. of War H. use of Rep.

make it lose a certain percentage of its cohesion. Lockmakers and those who use thin brass of this kind for springs well know that if it is exposed to the weather for some time it loses its cohesion, and breaks at the slightest pressure like pie-crust—in their phrase becomes “rotten.” Of course this is almost an imperceptible change, but some unaccountable variations of the adjustments of instruments (the heavier, the more liable) can only be explained on this hypothesis. The proper metal for instruments is an alloy with little or no zinc, and in density at least as close as the best hammered brass; hard “bell-metal” being the best.

A variation plate is also sometimes added to the ordinary transit in the manner of the variation plate of the ordinary Surveyors' Compass, and for the same purpose. This adds, however, to the weight of the instrument. Any contrivance for taking sights at a right angle to the telescope will be found useful for offsetting. We always add one to our complete transits.

The ordinary Plummetts that are used with the transit to centre it over a stake or point will also require examination, inasmuch as some of these, from cavities in their interior (from defective casting), although apparently solid on the outside, will not hang plumb; and in nice operations may be an unsuspected cause of error. The best method of testing these is while holding the string of the plummet in the hand, to twist the string somewhat, and while the string is untwisting, to lower the point of the plummet into a basin of water; if the weight is not truly distributed, and consequently the plummet not true, the eccentric motion of the steel point will scatter the water.

As the defects of the telescope will be treated under that head, and those of the magnetic needle under “Surveyor's Compass,” the reader is referred to those articles.

We here close the “errors of workmanship” of the transit instrument; as to the defects of the plan of their construction, and the methods devised for their remedy, the reader will find this subject treated in detail in the paper from the American Philosophical Journal, and the exhaustive report of the Committee of Civil Engineers, a little further on.

### Mining Transit.

A full description of our new Transit, intended for mining purposes, will be found in Prof. R. W. Raymond's paper further on. Since that paper has been written we have made several changes which render them more complete for the purposes intended. Instead of a prism to the eye-piece, an extra telescope is placed on the top of the axis of the regular telescope. This top telescope swings clear of the plates, and allows a vertical sight to be taken directly up or down a shaft; or any angle of elevation or depression to be taken too steep for the central telescope to measure. This telescope makes the instrument similar to the “eccentric or German Mining Transit,” with this advantage over that form—that when a steep slope is not required to be measured it can be removed in a moment and packed away in the box, and the cen-

tral telescope used as usual. This top telescope is adjusted so as to be parallel with the central one. It is also so arranged that the long level and vertical circle of the centre telescope can be used by the side one.

**Illumination.** As the proper reading of the graduations is one of the greatest troubles the Mining Engineer has to encounter, we have devised two articles to facilitate it. One is a small reflector that weighs  $1\frac{1}{2}$  ounces. It is metallic, in shape the quadrant of a cylinder, and it has a base or support which doubles up with the cylinder when not in use. It is placed just behind the vernier opening, and the light is reflected down upon the vernier, thus avoiding the soiling of the instrument with grease and smut, which occurs when holding the light over it, and the reflector can be removed when not in use. The other is a small attachment to the transit tripod for placing a lamp on; this consists of a small table, on which by a “Cugnot's joint” and double centre arrangement a lamp can be placed in any position or angle that may be necessary. This arrangement is strong, compact and effective, only weighing 24 ounces, and can be packed away in the transit box.

We also make a lamp weighing about 5 ounces, which is more compact than the one ordinarily used; it is crescent shaped on the interior to fit the curve of the observer's hat, and a simple arrangement secures it there. It can be quickly detached and used either in the hand or on the table above mentioned.

Copper should always be the material of the Mining Engineer's lamp, and this copper should be tested as to its freedom from magnetic attraction. We now furnish with our Plummet Lamps cases large enough to enclose a pair; a strap on the outside of this case allows it to be carried over the shoulder. The ordinary coal-oil such as is used for lamps is used; the wick to be adjusted for use so that the flame is about  $1\frac{1}{4}$  inches high. These last three (*i. e.*, the Reflector for the cross-wires, the Reflector for the graduations, and the Table) are also useful in taking astronomical observations with the ordinary Transit, such as, determining the magnetic variation, the true meridian, etc.

### Tunnel Transit.

The long tunnels which have been built of late years, and the numerous others that are contemplated or in the course of construction, have created a demand for an entirely new class of Transits, which are called Tunnel Transits. These heretofore have been nothing more than the bar and centre of an ordinary Levelling Instrument, with standards high enough to allow of the reversing of the Telescope, which generally has been the ordinary 17-inch Level Telescope. Our attention having been called to the defects of this mode of construction, we have devised one that possesses all the accuracy of the Astronomical Transit. In a Tunnel Transit, the principal adjustment being that of making the “line of collimation” revolve in a truly vertical plane, the same means employed in adjusting and testing the Astronomical Transit are also employed. The ends of the axis of the Telescope are cylindrical and resting on small Y's, to allow of its being taken out and reversed end

for end. A sensitive striding level is attached to the axis at right angles to the line of sight.

The Telescope should be as powerful as possible, as very long sights are necessary in this class of work.

### Leveling Instrument.

A first class Leveling Instrument should possess the following qualities:

(1). The Telescope should be powerful enough to read the face of a leveling rod direct (*i. e.*, without the aid of a target) at a distance of at least 800 feet.

(2). The object slide of the Telescope (like that of the Transit) should slide in and out in a perfectly straight line, so that the "line of collimation," when in adjustment for a long distance, shall be correct for a short one. The tests for proving the optical performance of the Telescope will be treated under the head of Telescope.

3. Level Tube. The interior of the glass level tube should be ground to a regular curve, so as to secure both accuracy and sensitiveness in the bubble; if the bubble, instead of being cylindrical in bore, should be slightly funnel-shaped (which is very apt to be the case without great care), it will be quite impossible to either adjust or level with accuracy. This serious but common defect is no doubt the unsuspected cause of much inaccurate leveling.

4. Tripod. The tripod and head should be very firm, and the centre of gravity of the level as near to the tripod head as possible. The centre of the instrument should be long, firm and well fitted to its socket, and *not detachable* from the instrument proper.

5. Adjusting the Telescope in the Wyes. Inasmuch as it is difficult, on steep sideling ground, for either the rodman or leveller to know whether the rod is held vertical, we always place marks on the collar of the Telescope and inside of the Y's; by observing if these are in contact, the leveller will be certain that when his instrument is leveled his vertical hair is truly vertical, and this enables him to keep the rod vertical, unless the rodman has a plummet or some contrivance similar to our "rod level."

6. Limit of Error in Leveling. We were much struck, in our correspondence with Mr. Morris and others, to learn what a diversity of opinion existed even among experts as to what could be called "close leveling,"—Mr. Morris in one of his letters asserting, "I have long ago made up my mind that no man can be considered a 'proficient leveller' who cannot run a line of levels in a circuit of 100 miles without differing more than one-tenth of a foot upon his closing bench-mark." On mentioning this test of proficiency in leveling to another practical engineer, he retorts in this wise,—"I have just, with my new level that you furnished me, run one line of levels about ten miles, and when I closed back on my bench to test my work found an error of 0.07 ft.,—this is

close work, but it would not be close enough for your friend (Mr. Morris). If any one should close on his bench with an error so small as he would expect (1-10 in 100 miles), I would say it was simply an accident, and the several errors (rod errors and distance errors) had in the aggregate balanced each other, and led him to suppose himself an expert."

A third thinks that even Mr. Morris's error is too large, and that the leveling rods that read to 1-1000 of a foot do not read close enough, and that for his own use he has had a rod divided so as to read by vernier to 1-10000 of a foot,—but as the Leveling Instrument of this last expert, which he declared was in perfect order and adjustment, was found, on trial by us, to be out of adjustment 3-10 of a foot in 300 feet, perhaps his opinion may not carry much weight.

The result of four series of test levels in France, of from 45 to 140 miles, averaged a difference of 1-10 of a foot in 43 miles, and the greatest error was 1-3 of a foot in 56 miles; another series of test levels in Scotland of two sets of levels of 26 miles was 0.02 of a foot. Mathematical analysis shows that for the same grade of work throughout, the error should be expected to accumulate as the square-root of the distance increases. The limiting error permitted on high grade levelling work on various government surveys is as follows:

	Formula (or its equivalent)	Permissible error in	
		10 miles	100 miles
U. S. Coast & Geod. Survey	$E=0.029 \sqrt{(\text{distance in miles})}$	0.092 foot	0.29 foot
U. S. Geod. Survey	$E=0.06 \sqrt{(\text{distance in miles})}$	0.158 foot	0.50 foot
New York State Survey	$E=0.020 \sqrt{(\text{distance in miles})}$	0.063 foot	0.20 foot
	$E=0.016 \sqrt{(\text{distance in miles})}$	0.051 foot	0.16 foot

7. Errors in Leveling. If the instrument is a good one, and in perfect adjustment, and used by a competent person, the only two causes of error in leveling that can occur (except by carelessness) are from what are called "rod errors" and "distance errors"—the "rod error" being caused by the assistant not holding the rod precisely vertical,—the "distance error" by the curvature of the earth affecting the result, when the "back" and "fore" sights are of very unequal length.

8. Rod Level. To counteract as much as possible these two causes of error, we have devised for the first a "rod level"—this "rod-level" is also intended for setting transit "flag-poles" vertical, as well as "leveling rods." It is an ordinary disk-level attached to an L-shaped piece of brass, a limb of the L extending downward, and at a right angle with the level. By placing this limb against the side of the rod or flag-staff and clasping it there, the rodman is enabled to know when his rod is vertical!



9. **Distance Wires.** For the distance errors, we place on the "diaphragm," or ring carrying the ordinary cross-wires, two extra hairs,—see article on Stadia measurements. These we adjust so as to precisely take in 1 foot of a rod placed at 100 feet distance from the instrument. After taking the level reading, the space on the rod enclosed by these hairs is also noted, and the rod sent in the opposite direction until the hairs enclose the same space. For example, if the hairs inclose 3 5-10 feet on the rod, the rod is 350 feet away from the instrument. To avoid taking the wrong hair in the "level sight" the "Stadia hairs" are placed vertical, and the telescope after taking the level sight must be turned quarter around in the Y's to read them. These Stadia hairs will also be found useful as a means of measuring distances quickly when "flying levels" are taken.

In a recess on the inner edge of the "clips" that confine the telescope in the Y's, there is generally placed a piece of cork, or a spring to bind the telescope. When this cork, etc., fails to bind, either a new piece of cork must be substituted or paper placed between to clamp. We have arranged our clips so that by slightly turning a milled head screw on their top the cork is forced out sufficiently to again bind the telescope.

**Defects.** One form of Level (one which we never use) that is liable to constantly lose its adjustments unless great care is used is that in which the cone of the socket enclosing the centre fits into a recess in the tripod head. If any flying dust settles on this socket (which it is almost impossible to avoid), it will cause it to stick so fast that to take the instrument from off the tripod requires a sudden shock upward to release it from the recess; this shock of course cannot but be detrimental to the adjustments. The best plan, when this form of instrument is used, is to be careful before setting the instrument on the tripod to be sure that both the outside of the socket and its recess are scrupulously clean; all the above causes of instrumental error in levelling are well known to those who make levelling a specialty, especially to the "Canal Engineer." The sudden death of the late Ellwood Morris, Esq., prevented the completion of a work for which he was peculiarly adapted, and for which he had been accumulating material for many years, on "Leveling and Leveling Instruments." After serving as a member of the Committee of Civil Engineers appointed by the Franklin Institute to examine our "Improved Transit," Mr. Morris entered into a long correspondence with us in reference to the defects of the ordinary Level, and the removal of them, in which he alluded to all the above defects. In referring to the above-mentioned defect of the object slide not moving in a straight line, he remarks: "One trouble I have frequently had—in the aberration caused by moving the tubes for short and long sights. I once had a Level which I never could make agree with itself in a transfer across a river, though I knew it was in good adjustment at all points. . . . I have realized these defects from long experience and much anxiety, but am not enough of a mechanic to give the true remedies. . . . I have said that good work has been done with modern Levels, defective as they are, but it has been with a world of care and trouble on the part of Assistant Engineers, who are very far from being stupid men."

In some level telescopes, it will be observed, while turning the telescope in the Y's, for the purpose of adjusting the cross-wires to the "line of collimation," that the object appears to move with the telescope. The cause of this is that the object glass is not well centered (*i. e.*, the optical axis of the object glass does not lie in the same line as the axis of the telescope tube); this is a serious defect that can only be cured by substituting a new glass or tube, according to the precise nature of the defect. This "error of centering" must not be confounded with the error of the line of collimation not being the same "for long and short distances," the first being caused by a "defective object glass," the second by a defective "object slide or tube."

### Telescopes.

**Requisites.** A good Telescope should possess **power, definition and light**; and every part should be made with the greatest care, so as to have as few adjustments as possible.

As to the method by which we have doubled the power of our Telescopes without increasing their length, the reader is referred to the articles on pages 62 and 63.

**Comparisons.** If two Telescopes are to be compared, as to their power, definition and light, they should be placed side by side, and looked through at the same time, in order that any atmospheric or local influence should affect both equally. The best time for telescopic observations is not when the sun is shining, as is generally supposed; on the contrary, a clear cloudy day, or when the sun is slightly obscured. Recollect also that the best sight is always in a direction opposite to the sun (*i. e.*, sighting to the west in the morning, to the east in the afternoon). A good background to the object will facilitate the view (the sky is a very good one if it can be obtained); if none can be had naturally, improvise one of some neutral tint behind the object. This is specially useful in long ranges. An optician's test, a watch dial, should be used; the difference of magnifying power between the two instruments can be seen by the apparent size of the dial; and if in one Telescope the dial appears twice as *large* as in the other, this Telescope has twice the magnifying power. In the telescope through which the dial appears *brightest*, the light is most abundant; and the sharpness of outline of the figures and minute lines will give a good test of the definition.

**Definition.** If the face of the dial appears sharp black and white, with no tinge of color, and the image as sharp at the edge as at the centre of the field of view, the chromatic and spherical aberrations are well corrected.

**Light.** To test the amount of light passing through the Telescope, let the two Telescopes stand side by side until twilight comes on; the one which will show objects the latest has practically the most light.

**Adequate magnifying power** is the first requisite in a Telescope, not only for viewing objects at a distance, but for the purpose of doing

more accurate work at comparatively short distances, as the ease with which sights can be taken and judged adds to the facility of the field work. Besides the above tests, after precisely focussing an object, the slightest pushing in or drawing out of the object glass (by means of its milled head pinion) from the point of distinct vision should render the image confused and indistinct, "for a Telescope that will admit of much motion in the sliding tube without affecting sensibly the distinctness of vision will not define well at any point, for its object glass has spherical aberration."

**Achromatism.** The following test will show whether the glass is perfectly achromatic (or without color): "focus on a bright object, such as a star, etc.; alternately push in and draw out the eye piece from the point of distinct vision. If in the former case a ring of purple is formed around the edge, and in the latter a light green (which is the central color of the prismatic spectrum), the glass is achromatic, for these colors show that the extreme colors red and violet are corrected." The placing of diaphragms or stops within the object slide or body tube, so as practically to reduce the diameter of the object glass from  $\frac{1}{2}$  to  $\frac{1}{4}$ , is a common but reprehensible practice, inasmuch as such diaphragms exclude light, so that operations cannot be continued to as late an hour in the afternoon.

On examining the object glass head of our Telescopes, an index mark will be found across the cell of the glass and the head of the slide. The object of this is, in case the object glass cell is ever taken out, that by seeing if these marks coincide when it is again screwed in, we may know that it is at the same place; or that the glass has not gotten loose by transportation.

**Defective centring of the object glass, and of the lenses of the eye piece, and crooked tubes** are by no means uncommon. These last defects, however, may be concealed (except from experts) by screw adjustments (in the manner of the web diaphragm) of the eye piece and object glass. If the glasses and tubes are true such adjustments are unnecessary; for if the object glass and the lenses of the eye piece of a Telescope are properly made and mounted, the tubes perfectly straight, the slides properly fitted, the line of collimation (when adjusted) must come in the centre of the field of view, and if it does not, something must be wrong in some part of the Telescope, and any means of adjustment only conceals the evil.

One error of judgment is also sometimes made, and that is that the bore of the Telescope tube itself is so small as to cut off considerable of the light from the object glass. Some Engineers prefer a small hole in the eye cap to sight through, others a large one; they must recollect that the size of this hole, as well as the size of the Telescope tube, is fixed by rule.

The eye-cap hole should always have a slide to cover it. Both this and the cap on the object glass should always be kept on when not in use. This is a point that is almost universally neglected; the cap as a general rule being lost within a few weeks' time; but if it is recollected that the fine polish of the object glass gives in a great measure the

sharpness and brilliancy to the object,—which if this polish is destroyed is also in a measure destroyed—more attention would be bestowed on it. Any one who has looked through an old ship's Telescope in which the polish has been destroyed by constant wiping of the glasses may have observed this.

**Cleaning the object glass.** If the object glass becomes dusty, brush it off with a fine camel's-hair brush, or a piece of soft, clean buckskin, linen or silk, taking care to use a fresh place on the buckskin at every rub. If the glasses become very dirty, wash them with alcohol.

### Surveyor's Compass.

**Requisites.** In a good surveyor's compass the slits of the sights should be precisely in a line with the two zero lines of the ring, and these sights should be at right angles to the main plate. It should be as light as is consistent with strength and steadiness. The magnetic needle is, however, the main point, and any one of the following defects will prevent its free working—bad steel, too great heat in forging, improper tempering or defective magnetism.

**Making the Needle.** We sometimes receive communications from parties wishing to make magnetic needles,—the following will give them the information sought for.

The steel should be either of shear or the best cast steel, converted from Swedish Dannemora iron (shear steel being the best, however). If the needle is forged into shape, care should be taken not to overheat it during that process. After filing and finishing into shape and length, it is to be hardened and tempered, and it is this operation that is most liable to be improperly performed, the needle being so thin that it is apt to get too hot in places, and burnt steel never magnetizes properly.

Our own method is to heat a crucible of lead to a cherry red color, and to heat the needle therein, and when it is to the proper heat plunge it into water,—the beauty of this method being that, even though the needle be allowed to remain a considerable time therein, it can never attain a greater heat than the lead itself has.

After hardening, the needle should be tempered. A good rule for the degree of hardness to which the steel is to be reduced is this: when the length exceeds thirty times the thickness, temper to dark red, or red blue; when the length is less than this, leave them untempered.

In magnetizing, two methods can be employed; first, by passing over each end the opposite poles of a fixed magnet; second, by a magnetic coil. If the first method be the one employed, a thin film of oil on the needle during magnetizing will greatly increase the power; but the method that is most certain of thoroughly magnetizing to "saturation," and with no possibility of "different polarities" being developed, is by passing the needle through a magnetic current.

To any one who wishes to make a coil for this purpose, the following hints may be useful. A cylindrical coil of copper wire as thick as it is long,—this cylinder to have a bore equal to its thickness. The copper wire should be rather thick. Our own coil is of  $\frac{1}{8}$  inch thick wire. The

exciting power should be a voltaic apparatus on "Groves'" principle (platina and zinc). The needle to be magnetized should be passed up and down the interior of the copper cylinder.

After being magnetized it is necessary to know if this has been done properly, *i. e.*, if the latent magnetism of the needle has been fully developed, and if this magnetism is permanent. To prove the first, the needle should lift a certain amount of soft iron; our own needles lift ten times their weight. Second, after noting the amount raised on first magnetizing, it should be tried, after say a week's time, and it should then have lost but little of its power. It must be recollected that a soft, untempered needle loses almost all its magnetism within a comparatively short time, though at first it will develop as much, if not more than a tempered one. If the reader wishes to investigate thoroughly the subject of magnetism and magnetic needles, he will find ample material in the works of Scoresby, Sabine, Brewster, or the *Encyc. Britannica*, art. Magnetism.

**Needle Cap and Pin.** The pin and the cap on which the pin works, require peculiar shapes—the centre of the cap to be at as obtuse an angle as possible, consistent with having a proper centre, and this centre perfectly smooth;—the centre pin to have a hard, round, smooth point; and this point with not too obtuse an angle. Defects of these two last (cap and pin) are in eight cases out of ten the cause of the dull working of the needle.

**Care of Needle.** To preserve the fine point of the centre pin from unnecessary wear or from being accidentally broken off, never jolt nor carry the compass without being sure that the needle is screwed off the pin. In using the needle, lower it carefully, so that it gently rests, and does not fall upon the centre pin.

To prevent unnecessary wear of the centre pin, check the needle on first letting it down at the mean of its swing. If the needle swings from say  $0^{\circ}$  to  $30^{\circ}$ , check it by raising it off the pin by means of its screw at  $15^{\circ}$ ; gently let it down again, and it will be within a few minutes of its proper settling place.

Never allow the needle to be played with by a knife or a piece of iron or steel, for two reasons;—first, the instrument should never be made a plaything; second, every near passing of a piece of iron or steel removes a portion of the magnetism of the needle (almost the entire magnetism can be removed by a series of such passings). A needle should never (excepting for special purposes) be more than six inches long, it being very difficult to magnetize properly beyond this length without developing different polarities on the same side of the needle. A five inch length is very good.

**Local Attraction.** Be sure that nothing to attract the needle is carried on the person in the shape of penknives, watch-chains, buttons, or iron rivets in the magnifier used to read the graduations. Of late years new causes of error from this have arisen. The new watches in which the movements are made of nickel are almost as powerful in attracting the needle as if these movements were made of iron. The felt hat-makers' modern fashion of stiffening the rims of their hats by in-

serting around the edge a small iron wire (the extra broad brimmed, termed the military or Burnside hat, should especially be tabooed) should make the Surveyor examine both his hat and watch.

**Iron in the Brass.** There is one source of error which even the manufacturer must have a special apparatus to detect; and this apparatus is as essential a part of his equipment as a lathe. This is a sensitive, mounted magnetic needle; and every piece of brass, even of the smallest size, is tested by being brought near to this needle, in order to see whether any magnetic attraction is concealed. The brass-founder is the one here in fault, as impure copper or the smallest piece of iron, such as a tack, core wire, or stirring his metal crucible with an iron rod will engender this cause. These impurities, melting and diffusing throughout the brass, although imperceptible to the eye, are brought to notice by the searching influence of the test needle. All the surveyors' Compasses made before the last 80 years are especially liable to error from this cause (those made by Rittenhouse are, however, notably free from it); and those who own any such should have them tried by some maker's "test needle" to prove their freedom from it.

It would be a matter of surprise to some to know how many needle instruments are defective from this cause, and we will give one instance that occurred lately. An **English Compass**, venerable with age and associations connected with it, had been constantly used by a Surveyor for over 50 years, and by his father before him. This Compass was held in such repute that all the farm lines in a radius of 100 miles had been established by it. In fact, the Surveyor and his Compass were held in such veneration as to be called in to settle every land dispute in the neighborhood, and the judgment of the two was considered final. At last the old Surveyor died, and such was the desire of the surrounding land Surveyors to possess this Compass that at the auction sale of his effects it was sold for treble the price a new one could have been bought for. The fortunate possessor brought it to us for cleaning and adjusting; and some vagaries that took place in the adjusting induced us to give the instrument a thorough examination; and we found that this defect of "impure metal" was present in such a marked degree that in turning the instrument on its centre it was sufficient to draw the needle from its proper position from 10 minutes to  $4^{\circ}$  (in some spots  $5^{\circ}$ ). This unequal attraction is one of the worst features in this imperfection; if the iron were equally distributed throughout the metal, the attraction being equal, the needle would still point true. We are not surprised to hear, since the old Surveyor's death, that several lawsuits are in progress in this locality from land disputes.

**Weight of needle.** One common error of Surveyors is to choose a heavy needle; this is a mistake. A heavy needle soon wears out the fine point of the centre pin. The superficial surface, and not the weight of the needle, determines the amount of magnetism it is capable of receiving.

**Static electricity.** One simple effect has sometimes bothered the young Surveyor. His needle will sometimes not traverse, but will per-

sistently stick to the under side of the glass; or one end at the lightest provocation would fly up to the glass and remain there. This is caused by the glass becoming charged with electricity, from rubbing against the clothing, or being rubbed by a silk handkerchief. Touching the upper part of the glass in several places with the moistened finger tip, or breathing on the glass, will remove the electricity. See also "an unsuspected source of error in magnetic needle readings of surveying instruments on page 25.

### How to Carry Transit and Compass Needles on Trolley Cars So as Not to Lose Their Magnetism.

#### Curious Freaks of Trolley Cars With Compass Needles.

##### EDITOR ENGINEERING NEWS:

Traveling in trolley cars has brought to notice a new danger to the compass needles of surveying instruments. Surveyors have naturally taken to riding on the trolley lines; they have just as naturally set their instruments on the floor of the car, forgetting that under the floor of each car are two powerful electro-magnets furnishing the magnetic field which produces motion in the armature, or revolving part of the motor. The field of a magnet extends far beyond it, but of course is most intense between and near the poles, but the magnets on a trolley car are so strong that they have an appreciable effect at some distance, and these huge magnets either entirely or partially discharge the magnetism from the needle, the amount taken from the needle varying according to the distance of the needle from the motor and the length of time it is subject to the motor's influence. During the last four months at least forty transits and compasses have been sent to us with the remark:

"Compass-needle don't work properly; on letting the needle down on pin the north end sticks up against the glass—don't know why. Monday needle worked all right; Tuesday it took this fit."

On investigating, found that on Monday after the survey the trolley car was taken to go home, instrument box placed on the floor immediately over the motor, and by the end of the ride the silent action of the motor on the needle had discharged all, or almost all, the magnetism. Under some conditions of trolley travel, not only has all the magnetism been removed from the needle (demagnetized), but it has been remagnetized and the polarity of the ends has been changed (*i. e.*, the north end has become the south end, and *vice versa*).

In the course of its manufacture a compass needle is a simple bar of steel, unmagnetized, nicely balanced on a centre pin. Then when it is magnetized, the north end becomes heavier and "dips," and to counterbalance the dip a little counterweight (generally a few coils of wire) is placed on the south end. It is evident, therefore, that if the needle should lose its magnetism, the counterweight on the south end having

no "dip" to counteract, would throw the needle out of balance and make the north end touch the glass.

It will be asked, "How can the surveyor discover whether a trolley ride has affected his needle, and how can he guard against the above trouble if he must ride in trolley cars?" As to the first, the surveyor has merely to see if his needle is balanced when it rests on centre pin. If it is balanced, no harm has been done. If, however, instead of this, the south end sinks and north end bobs up and remains fixed against the covering glass of compass box, it shows that magnetism has been taken from the needle, and it should be sent to the maker. For such remagnetizing it is not necessary to send the entire instrument to the maker for repairs; it will be sufficient to send the needle itself by registered mail. Surveyors in traveling on trolley cars, should enter and leave by the rear, and keep their instrument as far as possible from the motors, say, on the back platform. Under no circumstances should the instrument be put on the floor of the car; it would be better to put it on the seat or carry it in one's lap. Neither rubber nor glass will insulate magnetism. Rubber covers, however, serve to insulate against electricity, and so, also, do the rubber bumpers placed under all boxes. Needle instruments that are kept in modern, sky-scraping office buildings are also liable to be affected in the way described, owing to the presence not only of currents of electricity, but also of powerful magnets. It would be well to remind the surveyor that this clinging of the needle to the glass, caused by loss of magnetism, may be produced in another way by static electricity. If the glass be rubbed against the clothes or with a silk handkerchief it becomes electrified, and attracts the end of the needle to it; but this fault can be detected and easily remedied. Touching the moistened finger to the glass, the electricity is discharged, and the needle resumes its normal position. If it should not do so, then the needle itself has lost its magnetism, as heretofore explained.

Appended are some letters and extracts bearing on the subject.

CHAS. S. HELLER,  
(Heller & Brightly).

CITY OF BUFFALO,  
DEPARTMENT OF PUBLIC WORKS.

BUFFALO, N. Y.

Heller & Brightly:

I send by this mail needle of your transit to be magnetized and balanced. I had a peculiar experience with this needle, which is quite strange, as you will observe, yet. It worked to a charm up to last fall, when I took it home in the box on an electric car. When I attempted to use it again I found the polarity of the needle completely changed (north end pointed to the south), and accompanied with vagaries I could not account for. I tried to shift the balancing wire, but have made no success of it.

CHAS. H. TUTTON,  
Asst. Eng. Dept. Public Works.

SYRACUSE  
STREET RAILWAY COMPANY.

SYRACUSE, N. Y.

*Heller & Brightly:*

The day before yesterday I had occasion, in using my transit, to drop the needle in order to ascertain approximately the course of a particular line. The needle dropped, but, instead of settling or showing anywhere near the approximate course of the line, the north end of the needle persisted in clinging to the glass covering the compass box. I thought the glass had become charged with electricity, and took what means within my power to neutralize the action of the current. That evening I took the cover from off the compass box, and found that the needle would not balance properly under any condition, and that the north point of the needle would persist in not balancing, but would scrape against the glass, and, of course, this makes the needle practically useless.

C. LOOMIS ALLEN,

*Engineer Syracuse Street R. R. Co.*

(From Philadelphia Record.)

In making up their calculations regarding the formation of the country, the United States Geological Survey had need of the variation of the magnetic needle at various points, and they desired to have the magnetic variation of Philadelphia recorded. Chief Engineer Webster ordered the variation to be noted, but the city is so permeated with electric apparatus that the needle behaved in a most crazy manner. If a conduit happened to be directly beneath the needle, it pointed straight down, and, influenced by local conditions, it performed all sorts of extraordinary tricks. Finally the needle was taken to an isolated point in the Thirty-fifth Ward, far from any electrical influence, and the variation there noted.

### Trolley Cars and Surveying Instruments.

(From the editorial columns of the Engineering News.)

We have received several letters from Mr. Charles S. Heller, of the firm of Heller & Brightly, instrument manufacturers of Philadelphia, calling the attention of engineers to a new danger to the compass needles of surveying instruments due to carrying such instruments in electric cars.

Engineers frequently set down the cases containing compasses or transits upon the floors of cars, forgetful of the fact that beneath this floor are two powerful electro-magnets, which may either partially or entirely demagnetize the compass needle, the damage done bearing a strict relation to the distance of the needle from the magnets and the length of time this needle is exposed to their influence. During the past four months, says Mr. Heller, at least forty transits and compasses have been sent to his firm accompanied with the remark that trouble with the

needle had followed the transportation of the instrument in a trolley car. The north end of the needle would stick to the glass, and under some circumstances the polarity of the needle had been entirely changed by demagnetizing and re-charging, so that the north end pointed to the south.

As Mr. Heller explains, a compass needle is originally a simple bar of unmagnetized steel nicely balanced on a centre pin. When it is magnetized the north end, of course, "dips," and to counteract this dip a few coils of wire are usually wrapped about the south end of the needle. It is evident then, that if the needle is demagnetized the effect of the magnetic "dip" is lost, and the needle is thrown out of balance, with the north end touching the glass.

To detect whether a trolley ride has affected the needle of his compass, the surveyor has only to try the balance of the needle upon the centre pin. If it is balanced no harm has been done. If the south end sinks, however, and the north end strikes the glass covering the compass, the needle has been affected, and it should be sent to the maker for repair. For this purpose it will be sufficient to send the needle only, by registered mail.

Surveyors are advised to enter and leave trolley cars by the rear door, and to keep their instruments as far as possible from the motors, say, on the rear platform. Under no circumstances should the instrument be set on the floor of the car. If it must be carried inside the car it is better to put the box on a seat, or on the owner's lap. Neither rubber nor glass will protect from the magnetic effect, though rubber covers do insulate against electric currents, as do the rubber "bumpers" placed under all boxes. Needle instruments that are kept in modern very high office buildings are also liable to be affected injuriously, owing to the presence of electric currents and powerful magnets.

It is also well to remind the engineer that the needle may be made to stick to the glass by static electricity, produced by rubbing the glass against the clothes, or with a silk handkerchief. This effect is easily removed by discharging the electricity by the touch of a moistened finger to the glass. This experiment should be first tried in the case referred to, and if the trouble is not remedied by the needle at once resuming its normal position, then the needle has been demagnetized, as heretofore explained.

(From the Engineering and Mining Journal, New York.)

### An Unsuspected Source of Error in Magnetic Needle Readings of Surveying Instruments.

While engaged in taking some delicate bearings with a surveyor's compass, the writer was puzzled by the magnetic needle not giving the bearing of the same object twice alike; this sudden vagary of the needle was the more unaccountable from the fact that the compass was an exceptionally good one, with extra sensitive needle, and had heretofore always given very good results. An investigation was had as to the cause of the inaccuracies, and from the nature of them it was thought

that "magnetic attraction," in the shape of iron in the metal of the instrument itself, might be the cause; but an examination with a "test needle" proved this not to be the fact. The clothes of the observer were then carefully searched for anything that might have a tendency to draw the needle from its proper settling-place; but no pen-knife, steel watch-chain, nickel-plated sleeve-buttons, etc., could be found. It was, however, noticed while reading the needle that it never quite settled, but was in a constant tremor and vibration, and an examination of the magnifying glass used in reading the needle was made. The magnifier was similar to those now so universally used to read the verniers and needle-bearings of field instruments, having a black hard rubber or vulcanite frame, and this frame polished to a high gloss; and the whole cause of the trouble lay in this case or frame. It was found that this frame was peculiarly liable to become electrified; that the slightest friction, even the mere carrying in the pocket, was sufficient to charge it; and that when thus electrified, if brought near the needle of a compass, it had almost the effect of a loadstone in drawing it (sometimes as much as half a degree of arc) from its true settling-place. On discarding this magnifier, and using an ordinary glass lens without a frame, no further trouble was found in the field-work done with the compass. As all the instrument makers of this country furnish these hard rubber frame magnifiers with their field instruments, the liability of these frames to become thus electrified should be made known. Any surveyor having one of this class of magnifiers can convince himself of this fact in the following manner: Tear tissue paper or newspaper into small shreds; rub the frame of his magnifier briskly on the coat sleeve for a few moments; this friction will so charge the frame with electricity that, if held above the paper, the paper will fly up and attach itself tightly to the frame, or if held near to the "test magnetic needle" (which all instrument-makers use to prove their metal's freedom from iron) the needle will instantly be drawn to the frame, and stick there as if it were made of iron. This electrical trouble was found to be at its greatest in clear cold weather, and when the rubber cases were new and highly polished; greasing the cases was found to somewhat diminish the evil, and touching with the damp finger also discharged the electricity somewhat. Examination was also made of other magnifiers, those with brass, German silver and horn frames, such as are sold in optical stores, and on testing with the "test needle," the majority were found to be afflicted with "magnetic attraction," arising from impure metal in their cases, rivets, etc.

In consequence of these examinations one firm (Heller & Brightly, of Philadelphia,\*) have ceased furnishing these rubber magnifiers with their instruments, and have substituted other frames that will stand the test of the "test needle." In connection with this subject the following

\* These "non-magnetic attraction frame magnifiers" furnished by us are precisely similar in appearance to the hard-rubber frames mentioned above (the glass itself is, however, sharper defining than the ordinary store glasses), but with the important exception, that these horn frames cannot be excited electrically, as is the case with the rubber. Care is also taken that no magnetic attraction enters into the composition of the various pins and rivets, and that, when fully completed, they shall stand the severe test of the "test needle." If any surveyor who has been troubled with this electricity in his magnifier will send us in a letter one dollar and sixty cents, we will, per return mail, forward to his address one of these magnifiers, post-paid.

remarks, while not new, may not be out of place: "Be sure that nothing to attract the needle is carried by the surveyor in the shape of pen-knives, watch-chains, buttons, or iron rivets in the magnifier used to read the graduations. Of late years new causes of error from this have risen. The new watches in which the movements are made of nickel are almost as powerful in attracting the needle as if those movements were made of iron. The felt-hat makers' modern fashion of stiffening the rims of their hats by inserting around the edge a small iron wire (the extra broad-brimmed, termed the 'military,' should especially be tabooed) should make the surveyor examine both his hat and his watch."

There is, however, a general ignorance (especially among land surveyors) on this important subject, and one case that lately came under the writer's notice will be given in point: A land surveyor, not fancying the brassy look of his compass, had the entire instrument, with its ball and socket and sights, nickel plated, not knowing that as far as its effect on the needle was concerned he might as well have coated his instrument with iron. Aluminum has also been used instead of brass for instruments, but on account of the metal having "magnetic attraction" it is not suitable for needle instruments; this attraction is especially noticeable after the hammering process that is necessary to condense the aluminum after casting; this hammering "polarizing it," as it were.

#### Solar Transit and Compass.

The Solar Compass, or Solar Transit, as ordinarily made, has the following defects:—first, it is very heavy and cumbersome; hard to get in adjustment, and very liable to lose its adjustment; and the Solar apparatus, by occupying the upper surface of the plates, prevents a Telescope being added in the manner of an ordinary Transit.

We find that the Solar apparatus devised and patented by G. N. Saegmuller overcomes all the above defects, is more accurate, easier adjusted, and keeps its adjustments better than in any other form, and we have adopted it where a solar apparatus is required.

Prof. J. B. Johnson, of Washington University, St. Louis, Mo., has given it a thorough test, and wrote to G. N. Saegmuller as follows:

"In order to determine just what accuracy was possible with a Saegmuller Solar Attachment, I spent two days making observations on a line whose azimuth had been determined by observations on two nights on Polaris at elongation, the instrument being reversed to eliminate errors of adjustment. Forty-five observations were made with the solar attachment on Oct. 24, from 9 to 10 A. M., and from 1.30 to 4 P. M., and on Nov. 7, forty-two observations between the same hours.

"On the first day's work the latitude used was that obtained by an observation on the sun at its meridian passage, being  $38^{\circ} 39'$ , and the mean azimuth was 20 seconds in error. On the second day, the instrument having been more carefully adjusted, the latitude used was  $38^{\circ} 37'$ , which was supposed to be about the true latitude of the point of observation which was the corner of Park and Jefferson avenues in this city.

It was afterwards found this latitude was  $38^{\circ} 37' 15''$ , as referred to Washington University Observatory, so that when the mean azimuth of the line was corrected for this  $15''$  error in latitude it agreed exactly with the stellar azimuth of the line, which might have been  $10''$  or  $15''$  in error. On the first day all the readings were taken without a reading glass, there being four circle readings to each result. On the second day a glass was used.

"On the first day the maximum error was 4 minutes, the average error was 0.8 minute, and the 'probable error of a single observation' was also 0.8 minute. On the second day the maximum error was 2.7 minutes, the average error was 1 minute, and the 'probable error of a single observation' was 0.86 minute. The time required for a single observation is from three to five minutes.

"I believe this accuracy is attainable in actual practice, as no greater care was taken in the adjustment or handling of the instrument than should be exercised in the field.

"The transit has come to be the universal instrument for the engineer, and should be for the surveyor, so it is more desirable to have the solar apparatus attached to the transit than to have a separate instrument. The principal advantages of this attachment are:

"1. Its simplicity.

"2. Its accuracy of pointing, being furnished with a telescope which is accurately set on the sun's disk.

"3. In its providing that all angles be set off on the vertical and horizontal limbs of the transit, thus eliminating the eccentricity and other inaccuracies usually found in attachment circles or arcs.

"4. Its small cost.

"It is also readily removed and replaced without affecting its adjustments, and is out of the way in handling and reversing the telescope. It may be attached to any transit."

**Adjustments.** Saegmuller's solar attachment requires but two adjustments: (1) Make the polar axis perpendicular to the plane of the transit-telescope and the swinging axis of the transit-telescope. (2) Make the collimation axis of the solar parallel with the axis of its level bubble. The method of making these adjustments is so readily apparent to an engineer, accustomed to instrumental adjustments, that they will not be given here.

## TELEMETRICAL MEASUREMENTS.

For a certain class of measurements, the chain or tape has been superseded by several methods which permit the measurement of the distance by an observation of a rod at one end of the line by an instrument at the other.

1. Using a vertical arc. This method requires no special attachment except a vertical arc. If a transit telescope is levelled and sighted at a rod (held truly vertical) 100 feet away, and the telescope is then raised (or lowered) until the horizontal cross wire sights at a point on the rod exactly one foot higher (or lower), the telescope must have been moved exactly  $0^{\circ} 34' 22.6''$ . If the distance were 200 feet and the intercept 1 foot, the angle would be  $0^{\circ} 17' 11.3''$ —which is one-half the previous angle. By similar calculations we may construct a tabular form, of which a small sample is here given. It should be noted that for a distance of *about* 300 feet, the angle is between  $11'$  and  $12'$ , but the variation of a single minute varies the computed distance by 26 feet, and since the vertical angle cannot usually be read closer than single minutes, the uncertainty is very great. But by making the intercept 5 feet (or even 10 feet) the uncertainty may be proportionally reduced. The method is valuable at times, particularly as a check or when the other methods cannot be used—because the instrument is not equipped for it. But there are serious objections:— (a) it is not capable of as accurate use as the other methods—explained later; (b) it is far less rapid; (c) the above tabular calculations are *only* true for *level* lines; when the lines are inclined up or down, as is generally the case, the computations require to be "reduced," as with the other methods.

Intercept on rod—  
one foot

Vertical Angle	Distance
$0^{\circ} 10'$	843.77
11'	812.52
12'	286.48
13'	204.44
14'	245.55
15	229.18
16	214.80
17	202.22
18	190.98
19	180.93
$0^{\circ} 20'$	171.88
$0^{\circ} 30'$	114.89
$0^{\circ} 40'$	85.94
$0^{\circ} 50'$	68.75
$1^{\circ} 0'$	57.20

2. Gradiometer. The design of the gradiometer is very attractive. If it could always be depended on to do its work with mathematical precision, it would be more used, but it has been frequently noted that after a comparatively short use in the field, they fail to give correct results. The reasons were fully set forth in *Van Nostrand's Magazine* by Benj. Smith Lyman (Pres. Mining and Metallurgical Section of the Franklin Institute), and amplified in a paper to the *Engineering News*. The method is less rapid than the stadia; the attainable accuracy is less than the stadia (as proven by a long series

of comparative observations, made with this very purpose): the accuracy is vitiated by any jarring of the transit (however minute) that occurs while taking the *two* separate observations on the upper and lower marks. The last objection applies equally to the vertical arc method.

The gradienter has unquestionable advantages when used to run a line having a given grade. This operation may be made with a gradienter more accurately and more conveniently than it can with a vertical arc, while stadia wires cannot be utilized for this purpose.

3. **Stadia.** The utility of the stadia has now become so recognized that it should be considered a necessary attachment to all good transits. Its advantages are (a) **rapidity** of work; (b) **accuracy**; (c) **no appreciable addition to weight** of instrument; (d) **insignificant cost**. Since both wires can be viewed simultaneously, the instrument need not be touched nor the telescope moved between the two readings—as must be done with either methods (1) or (2). The distance from the center of the instrument to the rod always equals a constant ( $C$ , which is usually 100) times the rod reading ( $r$ ) plus the focal length of the telescope ( $f$ ) plus the distance from the center of the instrument to the object glass ( $c$ ); or

$$\text{Distance} = Cr + f + c.$$

The distance is the same as though measured from a point which is the distance  $f$  in front of the object glass.

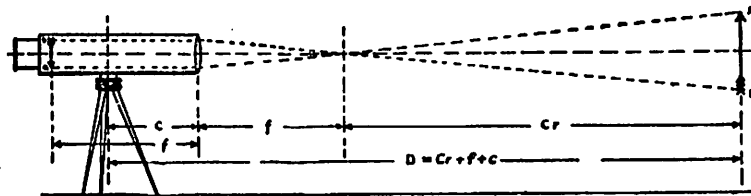

Although  $(f+c)$  is slightly variable, the maximum variation is far within the lowest unit of measurement of distance—which is usually 1 foot.  $f$  is easily measured by taking the distance (as shown in the figure) from the cross hair screws to the object glass and  $c$  is similarly measured. The sum of the two is usually about 15 inches, but when the lowest unit of measurement for horizontal distances is *one foot*, then  $(f+c)$  must usually be taken as one foot. When stadia wires are used on a "level" telescope,  $(f+c)$  may be over 18 inches, and then it should be considered 2 feet. Therefore it is only necessary to read the distance from the rod and add 1 (or 2).

*Fixed or adjustable stadia wires.* Fixed wires have the desirable quality of permanence, but it is almost impracticable to set and fix cross wires so that the "constant" ( $c$ ) shall be *precisely* 100. For an 8-inch focal length, the distance between the cross wires is only

.08", and to place them so that the error shall not exceed 1-5 of 1 per cent. requires that they be located to within .00016 of an inch. If the wires are *not* set with  $c=100$ , then (a) a special rod must be painted with units of such length that  $c=100$ , or (b) each observation must be reduced by means of a diagram or table. Adjustable wires *may* get out of adjustment, but they permit the use of ordinary rods and are easily adjustable. To test the wires, set up the instrument and send a rodman to a point, the distance from the instrument being 500 feet  $+ (f+c)$ . Fix the telescope so the middle wire is (say) 4.50 on the rod. Then test and adjust the wires if necessary so that the upper wire is on 7.00 and the lower wire on 2.00. This may be tested in a moment before each day's work, the base line being measured once for all. The wires hold their adjustment well, but an occasional touch may be necessary to keep them accurate. The wires should always be equally spaced from the middle horizontal wire—as shown in the cut.

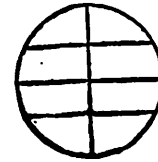



## HELLER AND BRIGHTLEY'S NEW TRANSIT.

A Paper Read Before the American Philosophical Society,  
by Prof. J. Peter Lesley.

(From Journal Proceedings American Phil. Soc.,

The Engineers' and Surveyors' Transit, as at first constructed, commonly termed a "flat centre," or "Railroad Transit," although superior to the English Theodolite, which it superseded, yet in practice has been found defective in the following mechanical details:

1st. The upper or vernier plate, resting, and turning upon the under or graduated limb, was accompanied by so much friction, caused by the large extent of the rubbing surfaces, that, in turning the vernier plate around the limb, the whole instrument would sometimes be moved upon the lower spindle. 2d. The oil that was necessarily used to lubricate the plates, would become so congealed in cold weather that the plates would not move at all, and old Railroad Engineers will readily recall the thawing out of their instruments over large fires, at every fall of the thermometer, before they could be used. 3d. The spindle upon which the entire instrument turns, being detached from the instrument, thus violating one of the standard rules, that, by long experience in this country and Europe, has been found necessary in the construction of any instrument with any pretensions to accuracy, viz.: "any instrument having a graduated plate and levels, should be so constructed that both of the centres upon which the instrument turns, should be always covered and not detachable from the main plates." To prove the utility of this rule, it is only necessary, after adjusting the levels of one of this class of Transits, so that they will reverse on the top centre, to clamp the two plates together, and turn the instrument on the lower spindle, and the levels will invariably be found out of adjustment, showing conclusively, that through some cause, most frequently the settling of flying dust, etc., upon the surface and shoulder of the spindle, the spindle is not at right angles to the surfaces of the plates. 4th. The centre around which the graduated limb revolves, can only be the thickness of the graduated limb; this centre, by reason of its small surface, wears after comparatively short use, and does not exactly fit the conical hole in the graduated limb; and two readings of the same object taken without any change in the position of the instrument, have been found to differ by 5' and from no other cause than this.

These various defects have caused this style of instrument to be entirely discarded in city work, and for this another construction is used, in which the two main plates do not touch each other, thus obviating the two first evils, viz.: the friction of the two plates rubbing one over the other, and the stiffness of motion of the plates in cold weather. The sockets and spindles upon which the main plates revolve, being

long and fitting one inside of the other, and neither of them being exposed or detached from the instrument, thus remedying the two last causes of error. These two are the only styles of Transit made, and are respectively termed the "short centre Transit" and the "long centre Transit." The "long centre," although the most perfect in its construction, has never been a favorite among Railroad Engineers for the following reasons:

1st. The increased size of the centres making it heavier, and this being a very serious objection where an instrument must be carried several miles every day, as is frequent in Railroad surveys. 2d. The instrument not being detached from the tripod, except at the base, compelled the Engineer in moving the instrument from one station to another, to either carry the entire instrument himself, or trust it to his assistant; while in the short centre, the instrument lifting off the spindle, the Engineer could take the comparatively light instrument, with all the important parts, and leave his assistant to carry the heavier portion of the tripod, with its leveling screws, legs, etc. 3d. The removing and replacing of the instrument on the tripod, being accomplished by means of a large screw thread, is a very tedious and unsafe method, and if not very carefully performed, is liable to injure the instrument. 4th. The extra skill, time and care required in making the long centre, was so much greater than the flat centre, that the price of the instrument was materially increased.

Ever since the introduction of the Transit, numerous endeavors have been made to reduce the weight of the instrument, but as they have all been conducted on the same principle—i. e., reducing the thickness of the various plates, etc.—their only effect was to make the instrument so slight as to be unsteady, their bearing surfaces so short as to soon wear loose, and the instrument always losing its adjustment. The manufacturers of this instrument have had their attention drawn to the increased strength and steadiness that the employment of the "transverse section," "ribbing or bracing," imparted to metals; and the amount of metal that could be removed from a solid plate of metal, and its strength and steadiness not impaired, but even added to, if only judicious ribbing was resorted to. In this improved Transit, which is a long centre, the weight as compared with an ordinary Transit of the same size, is reduced one-half, and the instrument is not contracted in any part, but in some parts, where increased size would be an advantage, such as the graduated plate, centre, etc., it has been done, but all the plates, etc., are ribbed in such a way, as to be stronger than a solid plate, and all metal that did not impart either strength or steadiness has been removed.

The Railroad Engineer has in this instrument, a long centre Transit that can be taken from off the tripod and replaced in a quicker and sure way than the short centre Transit, but, unlike the short centre, keeps all the centres covered and not removable from the instrument, and leaves the tripod head and legs with the four levelling screws, etc., to be carried by his assistant. The difference in weight will be appreciated by the Railroad Engineer, when we inform him that a plain Transit, with all its centres, etc., only weighs about as much as a

Surveyor's Sight Compass; and is more steady and keeps in adjustment better than the ordinary long centre Transit, weighing from twenty-five to thirty pounds.

The City Engineer has in this instrument all the advantages of the ordinary "long centre Transit" with only half the weight, and an increase of steadiness.

There are several defects that are common to all Transits, among which are—

1st. The "tangent or slow motion screw" that moves the upper or vernier plate, by use becomes worn, and does not fit precisely the thread in the interior of the nut through which it passes. When this occurs, the tangent screw can be turned sometimes a complete revolution without moving the vernier plate. This "lost motion" or "back lash" of the tangent, is one of the worst annoyances of Engineers, and has been the source of serious errors in the field. Several methods have been devised to overcome this, which we will here describe. The nut through which the screw works has been made in two sections, to allow of being drawn together when the screw wears. This plan would answer if the screw always wore equally in every portion of its length—in other words, was a cylinder—but this it never does; and if the nut is tightened so that the lost motion is removed from the thinner portion of the screw, it will move so tightly as to be useless when it comes to the portions that are not worn so thin. There are several methods of drawing the nut together, but they have all the same objections as the above—that is, they are not effective in the entire length, and the nut must be pressed so very hard on the screw as to make the working of the tangent very tense, especially in cold weather. Another and the last method has been to apply a long spiral spring between the nut and the head of the screw that acts as the finger-piece, thus pressing the nut and the screw from each other, and consequently removing all "lost motion" from the screw. This plan, though in theory very good, in practice has been found inoperative, for the following reason: the spiral spring had of necessity to be made long enough, and stiff enough, to act in every portion of the screw's length, the alternate opening and closing of the spring by use weakened it, and in a short time it failed to remove the "back play." To get rid of this defect of "lost motion" in the tangent screw; opposing or butting screws have been sometimes substituted, but in use they do not give satisfaction, as two hands must be employed in using them, and standing from the edge of the plate, they are liable to be injured by blows, and they are apt, unless very carefully used, to throw the instrument out of level.

In this instrument we have an improved tangent screw, that, no matter how much the screw may wear by use or time, will never get "lost motion," but will instantly obey the slightest touch of the hand: this is effected by means of a long cylindrical nut, from the interior of which two-thirds of the screw have been removed; into half the recess thus left in the nut, is nicely fitted a cylindrical "follower," with the same length of screw thread as the nut; this follower is fitted with a "key," that prevents it turning in the recess, but allows motion in the direction of its length. A strong spiral spring is placed in the remaining half of

the recess, between the fixed nut and the movable follower, and the spring has always tension enough to force the follower and fixed thread in contrary directions, and thus to remove any "lost motion" that may occur in the screw. It will be observed that in this method, the spring always remains in a state of rest, instead of closing and opening, as has been the case in all other applications of springs, and which have been the cause of their failure. Tangent screws that have had as much as 10' play have been made to work entirely taut by this method.

The mode of attaching the tangent screw to the plates in this instrument is entirely new; it is a miniature modification of the "Gimbeling" of a ship's compass, and allows the tangent screw, by its free swivelling, to be tangent to the plates in every part of its length, and thus never to bind. This tangent screw is also of value for sextants, astronomical instruments, etc., where "lost motion" is detrimental, and a smooth, easy motion is required. In all instruments the brass cheeks in which the three legs of the tripod play are fastened to the lower parallel plate by a number of small screws, commonly twelve. When the legs wear in the cheeks and become unsteady, the only method the Engineer has of tightening the legs is by drawing the cheeks in which the leg moves by means of the bolt that passes through the leg; this of necessity draws the cheeks out of perpendicularity, and strains the small screws that bind the cheeks to the parallel plate so much as frequently to loosen them. This source of instrumental error hardly, if ever, occurs to the Engineer, but very good instruments have been condemned as unsteady, when an examination has shown the fault to be the above. This source of error can never occur in this instrument, as the cheeks and the parallel plate are made in one solid piece. But to come to the last and most serious evil. The effective power of the Telescope is impaired by spherical aberration; that is, the field of view, as seen in the Telescope, is not a perfect plane or flat, but is spherical. To prove this, take an ordinary telescope and focus it so that an object will be clearly defined at the intersection of the cross hairs or the centre of the field of view; then, by means of the tangent screw, bring the same object to the edge of the field of view, and it will be found in every case to be indistinct and not in focus; on the contrary, focus it so as to be distinct at the edge, and it will be indistinct when brought to the centre. In some telescopes, however, it is impossible to focus at the outer edge of the field, and objects will be tinged with prismatic colors, showing that these glasses are affected by chromatic aberration also; sometimes the cause of this defect lies in the object glass, but in the majority of cases the lenses composing the eye-piece are in fault.

These aberrations affect the working of the telescope in several ways. First, it practically diminishes the size of the object glass, and the view is never so clear and distinct as it ought to be. Second, it is very difficult, and in some cases almost impossible, to adjust the eye-piece to prevent parallax, or "travelling" of the cross wires, when the eye is shifted from side to side; and practical Engineers know what a sharper power of defining and how much less trying to the eyes a "soft glass" has—that is, one that has a "flat field." This defect has prevented the general use of the Stadia, or Micrometer wires, as a method

of measuring distances without a chain, as the two horizontal hairs that are used, being in different parts of the field of view, cannot, in a majority of cases, be focussed so as to be devoid of parallax, and the slightest travelling of the wires in this operation will give an erroneous result. The evils of this defect were most forcibly brought to Mr. Heller and the late Wm. J. Young's notice when one of their best Transits failed to define in tunnel work, from loss of light, from this cause; and they both endeavored, to within a short time of Mr. Young's death, to remedy it, trying all the known formulæ of almost all the opticians in the country, but without any good results. In the Telescope of this instrument these evils are entirely removed by the employment of a new eye-piece, and advantage has been taken of the improvements that Optics have made in the last few years in the curvatures and arrangements of the lenses that compose it; and the test referred to above, of focussing an object in the centre of the field of view and then bringing the same object to the edge, and it still remaining in sharp focus, can be done with this telescope, and the object shows no tinge of prismatic color, showing that both chromatic and spherical aberration have been removed.

The advantages of this improved Telescope are: a clear and sharply defined field of view; a field of view so flat that the cross hairs are without parallax in every part of it, and micrometer hairs or Stadia can be used with favorable results. The whole affective power of the object glass being used and none of the light lost, work can be commenced earlier in the morning and continued later in the afternoon than is usual. This, in the winter season, is no slight matter to the engineer; and lastly, there is no straining of the eyes in sighting. The spider's web, by reason of its fineness, is the only article hitherto used for cross hairs, yet in use these have been attended with some difficulties; first, the spider's web is hygrometric, or is affected by the humidity of the atmosphere—when exposed to dampness lengthening, and of course throwing the line of collimation from its true place. This defect is more serious in the Engineer's Levelling Instrument than in the Transit, instances being known where the line of collimation has altered two or three times in the course of ten hours by reason of atmospheric changes, and of course any observation taken at those times would be defective; lastly, the spider's web being a transparent and not an opaque substance, in some positions it is impossible to see the hairs at all: this is more especially the case when sighting in the direction of the sun—that is, an easterly course in the forenoon, or westerly in the afternoon. To remedy this defect, platina cross hairs 1-1000 of an inch in thickness, or as fine as spiders' web, are substituted; these being opaque, and not transparent, in sighting in the direction of the sun are still visible, and any atmospheric changes, dampness, etc., do not affect them. They believe that they are the first ones in this country who have drawn wire so thin, and the only ones who have made any practical use of Dr. Wollaston's experiment. The platina hairs are invaluable in Mining and Tunnelling Instruments, that are so constantly exposed to dampness, and being opaque, no reflector to illuminate the cross wires is required.

To prevent the stiffness of working of the levelling, tangent and other screws in cold weather, which arises from the congealing of the grease that is used in lubricating them, no oil is used upon the screws of this instrument, but they are lubricated with pure plumbago.

By a simple arrangement of the clamps on the axle of their complete Transits, they make them also answer the purpose of a pair of Compass sights, for taking offsets at right angles to the telescope.

From the above, it will be seen that this instrument has the following improvements over the ordinary Transit: 1. A simple, secure and steady method of attaching and detaching from the tripod, being the only long centre transit made that detaches as easily as a short centre. 2. An important decrease of weight, without decrease of size, and an increase of steadiness. 3. All the working parts of the tangent screw, etc., brought within the plates, making the instrument more compact. 4. An improved tangent screw, telescope, cross hairs and tripod head. 5. A pair of sights for taking offsets; and 6. A new method of lubricating the screws.

#### Report of Committee of Civil Engineers Appointed by the Franklin Institute to Examine a New Transit Instrument.

No. 863.

HALL OF THE FRANKLIN INSTITUTE,

Philadelphia.

The Committee on Science and the Arts constituted by the Franklin Institute of the State of Pennsylvania for the promotion of the Mechanic Arts, to whom was referred for examination the Transit instrument made by Messrs. Heller & Brightly, Philadelphia,

#### REPORT

That the instrument exhibits the best of workmanship, and combines several novelties of construction which, in the opinion of the Committee, render it superior to those now in common use. Among these novelties are: 1st. A great reduction of weight, without any loss of strength or steadiness. 2d. An improved method of attaching and detaching the instrument to and from the tripod head. 3d. All the working parts of the tangent-screw, etc., are brought within the circumference of the plates, thus diminishing liability to injury, and at the same time making the instrument more compact. 4th. An improved tangent-screw. 5th. Cross-wires of platina instead of spider's web. 6th. A pair of sights placed in the standards, by means of which a right angle can at all times be laid off from the line of the telescope; this is very useful for taking offset from the line of survey. 7th. An improved telescope. 8th. A shifting or extension tripod leg, for use in mining or other contracted workings. 9th. The brass cheeks for the legs and the tripod head are cast in one piece. 10th. An improved lubricator for the screws.

The following is a detailed description of the above-enumerated improvements.

First. The weight is reduced to about one-half that of an instrument of the same size, made in the usual way, by ribbing and bracing the plates, etc.; and all metal that does not impart either strength or steadiness is removed, the size of the instrument not being reduced thereby in any part.

Second. The method of attaching the instrument to and detaching it from the tripod head is as follows: The upper parallel plate of the tripod head has two (2) fixed and one (1) movable lug on its upper surface. These three (3) lugs are placed equi-distant from each other. There is also a flange on the exterior of the socket which encloses the centres. Three (3) recesses on the edge of this flange allow the flange itself to lie on the parallel plate and to enclose the lugs. The whole instrument is now turned until the lugs are outside of the recesses, and the whole is then clamped by the milled head-screw of the movable lug. By this process a three- (3) pointed clamp is obtained. A forked guide-piece fitting into a groove in the clamp-screw and traveling with it prevents its being screwed out and lost.

Third. An examination of the instrument renders this third point so obvious as to require no explanation.

Fourth. The tangent-screw is constructed so as to overcome all lost motion in the following manner: A long cylindrical nut has two-thirds of its screw-thread removed. In one-half of the recess thus formed is fitted a cylindrical follower, with a key which prevents its rotation, but permits it to move forward or back. A spiral spring is placed in the other half of the recess, the tension of which forces the fixed thread and follower in contrary directions.

Fifth. The platina cross-wires (1-1000 of an inch in thickness, or as thin as ordinary spiders' web) prevent the sagging which the spiders' web undergoes from dampness. Not being transparent, they can be easily seen when sighting toward a light. This is an advantage when looking toward the sun, or when locating a meridian line by means of the North star.

Sixth. A pair of right-angle sights is obtained in the following way: The slits in the clamps on the axis of the telescope are extended downward so as to reach almost to the bottom of the clamps, and in these slits the sighting-holes are made. The slits are then adjusted by the maker to cut a right angle, and index marks are then made on the clamps and standards. By bringing the index marks to coincide, an accurate sight at right angles to the telescope is had.

Seventh. The curvatures and distances of the lenses composing the eye-piece are so arranged as to overcome all spherical and chromatic aberration in the telescope. The spherical aberration of the ordinary telescope has prevented satisfactory results from Stadia measurements.

Eighth. The shifting tripod leg has a play of from three (3) to five (5) feet. It is composed of two (2) semi-circular cylinders, sliding one on the other on their plane surfaces, as in a levelling-rod, and

clamping in any position. This leg dispenses with eccentrics, and will slide easily and clamp well, even if the wood of the halves be swollen or warped.

Ninth. Having the tripod head and the cheeks for the legs in one piece prevents the possibility of any unsteadiness from the loosening of the cheeks from tightening the legs.

Tenth. Pure plumbago is used as a lubricator for all the screws, preventing hard working in cold weather.

The side adjustment on the standard, by which one end of the axis of the telescope may be raised or lowered in order to make the vertical hair lie in a vertical plane through the axis, and the nice balancing of the telescope upon its centre of gravity, are also noticed as very important features in engineers' transits. There is, however, no claim to novelty in the application of these principles.

The ribbing of the instrument is judiciously placed, and the metal of which all castings are made is bell, instead of the ordinary brass. The Committee see no reason why it should not keep its adjustments and maintain its steadiness at least as well as any other. To solve all doubts, however, on this subject, letters were addressed to two engineers who had been using the transits of Messrs. Heller & Brightly almost daily for six (6) months. Both were engaged in operations requiring the best instruments—viz., one in city street locations, and one in a tunnel nearly four thousand feet in length. The answers of both were satisfactory in the highest degree, pronouncing said instruments superior to any they had ever used.

The substitution of platina wire for spiders' web was found to be especially advantageous in tunnel work, by contributing in an appreciable degree to the accuracy so necessary in that kind of work or in mining.

In conclusion, the Committee express themselves highly pleased with the instruments of Messrs. Heller & Brightly, and consider it but a simple act of justice to these gentlemen to say that, in its opinion, the deviations which they have made from the common styles of transit are decided improvements. It may not be amiss to add that their instruments cost no more than those of the ordinary style of our best makers.

JOHN C. TRAUTWINE, *Chairman.*  
CHARLES S. CLOSE,  
LEWIS M. HAUPT,  
SAMUEL L. SMEDLEY,  
ELLWOOD MORRIS.

By order of the Committee,  
D. S. HOLMAN, *Actuary.*

The following are the two letters of inquiry referred to by the Franklin Institute Committee in their report. The letters to which these are answers had, among other inquiries, the following: Is the instrument steady? Does it keep its adjustment? If not, how frequently has it been adjusted since you first received it?

BURLINGTON, N. J.

MESSRS. HELLER &amp; BRIGHTLY, PHILADELPHIA.

*Gentlemen:*—Your inquiries regarding the Transit purchased of you last spring is at hand.

I am happy to say that when put to test of unremitting use for several months with constant and critical examination during the entire period for the discovery of faults that are ordinarily supposed to exist, I have not been able to detect anything amiss.

Besides using the Transit for the customary purposes of a general practice, I have employed it in the careful reorganization and rectification of the Surveys of our city, and the preparation of a strictly accurate Atlas, similar to that which is in use in the Survey Department of Philadelphia; and in two very essential respects I have found it superior to any other that I have ever known; I refer to stability and permanence of adjustment.

I have frequently left it standing in one position for hours, and on my return found the telescope maintaining the same line with entire exactness; and in point of adjustment, it is as correct and reliable to-day as it was after the searching examination you gave it in my presence on the day of its delivery to me.

The graduation of the plates is exceedingly accurate, and in that respect my Transit is superior to the majority of those in common use; in fact, the results obtained from its use have been such that, had they not been frequently repeated with equal success, should have been attributed to chance.

The needle, too, is excellent in all the essential particulars of straightness, correct centring and magnetic power. In perhaps a hundred readings of angles by the needle as compared with the readings of the vernier, in no one has the difference amounted to more than three minutes. I am yours, etc.,

H. S. HAINES.

OFFICE OF THE LEHIGH COAL AND NAVIGATION COMPANY,  
NESQUEHONING TUNNEL, Pa.

MESSRS. HELLER &amp; BRIGHTLY, PHILA.:

*Dear Sir:*—Your favor of 28th ult., inquiring about the instrument made for use on this work, is received.

The instrument has proven entirely satisfactory in every respect; it is perfectly steady—it keeps its adjustment admirably, it not having been touched in this respect since it came from your shop, and is now perfectly correct.

The platina hairs have never shown the least indication of sagging from the moisture of inside work, and they are the only hairs that we have not had trouble with in this respect; the instrument has frequently been in the dampness of a Tunnel for hours at a time. \* \* \*

We were enabled to bring our lines together with your instrument with a lateral variation of  $1\frac{1}{8}$  inches in a Tunnel 3800 feet long.

We have found another great advantage in the use of the platina: namely, that when the light is reflected on them by a lamp, instead of the indistinct line which the spider web gives, we have a clearly defined black mark.

Yours, etc.,  
THOS. C. STEELE, Engineer.

### On a New Mining Transit and Plummet Lamp.

(From Van Nostrand's Engineering Magazine)

A communication to the American Institute of Mining Engineers, at the Boston meeting,  
by Prof. R. W. Raymond,  
President of the Institute:

Having had recently the opportunity of examining a Transit and a Plummet Lamp, manufactured by Messrs. Heller & Brightly, of Philadelphia, and intended for the use of mining engineers in underground surveying, I thought a description of them would be interesting to such of our members as have work of that kind to do, and accordingly I requested the makers to prepare and send to me a detailed account. There is nothing specially novel, I may remark, in the construction of the Transit; its claims to favor must rest upon its compactness and lightness, together with the general excellence of its workmanship. The principal peculiarity is the ribbing and flanging of the parts requiring strength, so as to dispose the minimum amount of material where it will secure the greatest rigidity. This transit is said to be the lightest of American make. I believe Caselli has sent some from London which are still lighter; but they are perhaps not so completely furnished for field work. I confess I do not see how the weight can well be reduced any further, unless an instrument can be made of aluminum—a plan which Mr. Rothwell once suggested; but which may not, perhaps, be entirely practicable, and, at any rate, has not been tried.

The following is the manufacturers' description of this Transit, which they have designed and introduced within the last year:

It is a small portable angle instrument, similar in principle to the ordinary "Engineer's Transit," and a *fac simile* in every respect (excepting size and weight) of their "complete Engineer's Transit." It has long compound centres; the horizontal limb is read by two double opposite verniers, placed outside the compass box; the vernier openings in the plate being made very wide, so as to allow the easy reading of the graduations. There is a three inch magnetic needle, and its ring is divided to half degrees. The telescope is  $7\frac{1}{4}$  inches long, with object glass fifteen-sixteenths inch in aperture, and shows objects erect and not inverted. A sensitive level,  $4\frac{1}{2}$  inches long, is attached to the telescope, for reading angles of elevation and depression, levelling, etc. The tripod is furnished with an adjustable head for precise plumbing of the instrument over a centre; and the wooden legs of the tripod are made in such a manner as to form one leg when folded together. The plates, vertical circle, etc., are provided with clamps and tangent-screw movements; and the clamps on the axis of the telescope are arranged with sighting screws and indexes, so as to answer also for right angle sights.

The numbering of the compass ring and horizontal limb, instead of being in quadrants from  $0^\circ$  to  $90^\circ$  each way as usual, is a continuous one, or from  $0^\circ$  to  $360^\circ$ ; but every quadrant of the horizontal limb is also marked with its magnetic bearing, *i. e.*, from  $0^\circ$  N. to  $90^\circ$  E., every ten degrees is marked N. E.—from  $90^\circ$  E. to  $180^\circ$  S., every ten degrees is marked S. E., etc. The advantage of this arrangement is, that, if at starting, the vernier of the horizontal limb be set to read the same bearing as the needle, the needle can be screwed up, and both the angles and magnetic bearings—read from the horizontal limb, without using the needle for the remainder of the survey, thus precluding any error from local attraction, reading from the wrong end of the needle, or loss of time in waiting for the needle to settle. The telescope, though short, is a very powerful one, magnifying and having the clearness of an ordinary 17-inch level telescope. A reflector for illuminating the cross wires in dark places is used, as is also an extension tripod leg for lowering or raising the instrument. All the working parts of the needle-lifter, clamp and tangent screw movement are concealed between the plates, making the instrument more compact. A prism and tube for attaching to the eye-piece of the telescope, for sighting vertically in shafts, is also furnished. The weight of the instrument, exclusive of the tripod, is about  $5\frac{1}{2}$  pounds; the weight of the tripod is  $3\frac{1}{2}$  pounds; the height of the instrument from the tripod legs is 7 inches; the extreme diameter of plates, 5 inches; the diameter of the horizontal plate at the point where verniers and graduations meet,  $4\frac{1}{2}$  inches. The instrument and tripod head are packed in a box  $7\frac{1}{2}$  inches square, arranged with straps to allow its being carried over the shoulder in the same manner as an army officer's field glass, while the folded tripod legs answer as a cane. Though these instruments have been specially designed for mining use, yet from their lightness and compactness they are also meeting with favor for geological surveys, and for preliminary railroad reconnoissances; when used for these purposes, an extra pair of hairs for stadia purposes (*i. e.*, measuring distances without chaining), besides the ordinary cross-hairs, is added.

The same manufacturers make a very convenient Plummet Lamp, for underground work. It consists of a brass lamp, suspended by two chains, and terminated below in a conical plummet. The so-called compensating ring is an equatorial ring, surrounding and supporting the lamp, which swings freely within it, upon an axis. The two chains are attached to this ring at the extremities of a diameter perpendicular to the axis. By means of this arrangement, the point of suspension, centre of lamp flame, and steel point of plummet always lie in a true vertical line, no matter how much the brass supporting chains may alter in length from the heating of the Lamp, kinking or wearing of the links. A shield at the top prevents the flame from burning the string. These Lamps are generally used in pairs for back and forward sights.

I understand that Mr. McNair, of Hazleton, and Mr. Coxe, of Drifton, both members of this Institute, have used this instrument with satisfactory results.

### Use of the Plummet Lamp in Underground Surveying.

(From Van Nostrand's Engineering Magazine)

A paper read at the Boston meeting of the American Institute of Mining Engineers,  
by Eckley B. Coxe:

In the anthracite coal regions of Pennsylvania the custom has been to sight either at an open light (generally a mine lamp), or at the string of a plumb-bob. If the station was intended to be a permanent one, a spud, as it is called, that is, a nail resembling a horse shoe nail, with a hole in the head, is driven into the timbers over the station, or, if there be no timber, a hole is drilled in the coal or rock roof into which a wooden plug is driven, which serves to hold the spud.

The first operation in making a survey, is to lay out the stations, that is, to mark the place where the holes are to be drilled for the points on the timbers where the spuds are to be driven in. This should be done before any instrumental work is begun, as much labor can generally be spared and the use of very short sights can often be avoided, by carefully laying out the stations beforehand. When the stations were laid out, a plumb-bob was hung from the innermost spud, which I will call No. 1, the instrument was put in position at No. 2, by plumbing down and putting a centre pin under the spud, and then setting up over the centre pin, and another plumb-bob was suspended from No. 3. If great accuracy was not required, a mine lamp was set up under the plumb-bobs at No. 1 and No. 3, and the engineer sighted at them. If great accuracy was required, a lamp or some white surface was held by an assistant behind the strings of the plumb-bobs. To work with any speed by the latter method (*i. e.*, the accurate one), it was necessary for the engineer to have three assistants on whom he could rely, even when the chaining was done afterward, *viz.*: one to hold the light behind the string at No. 1, one at No. 3, and an assistant at the instrument to hold the light while leveling, reading the instrument, etc. When using lamps on the ground it is necessary to examine them from time to time to see that they have not sunk in the mud or turned on one side, etc.; besides, the flame of a mine lamp is a very large object to sight at, and sometimes it is impossible to see it on the ground (when it can be well seen two or three feet above it), in consequence of some intervening obstacles. Being so situated that it was necessary for me to do a certain amount of accurate work, where I could not rely upon having more than one competent assistant, I had the plumb-bob lamps constructed, and I work with them with a single assistant in the following manner:

When the stations have been laid out, I go to station No. 2 with the Transit, and by means of the plumb-bob belonging to the instrument, I place the centre pin, (a small block of lead with a steel pin in it,) precisely under the spud No. 2; I then remove the plumb-bob and set up my instrument. While I am doing this, my assistant takes the two lamps, suspends one from spud No. 1, and the other from spud No. 3, and then comes back to hold the light for me while I make the final adjustments and take the readings. My instrument is graduated to  $360^\circ$ , and has two verniers  $180^\circ$  apart. I set the vernier at zero, and sight backwards to lamp No. 1. The flame is very small and has a blue cen-

tra cone which I bisect. I then read the compass needle, invert the telescope, deflect and sight at No. 3, and read both verniers and the needle. I then turn the telescope back, sight upon No. 1, and turn the vernier plate round nearly 180° until I sight No. 3, and again read both verniers. I obtain thus four readings of the deflection from the vernier, and a compass reading as a check, and, as the lights are steady and small, the readings can be made very accurately and quickly. If the four readings agree (with their difference of 180°), I am sure there is no mistake and go on. I then take up my Transit, go to No. 3, run down the lamp to near the ground, put my centre pin under it, remove the lamp and begin to set up.

In the meantime, the assistant brings the lamp from No. 1 to No. 2, and then takes the lamp from No. 3 to No. 4, and comes back to No. 3 to assist me at the reading of the instrument. The work goes on in this way until all the angles are measured. I then go back and chain the distance from one station to another, and take notes of the workings, etc. In this way, two persons can make a very accurate survey as quickly as three can by the old method. Of course if one has assistants enough the chaining can go on with the instrumental work.

WHAT SOME NOTED CIVIL ENGINEERS SAY ABOUT  
HELLER & BRIGHTLY INSTRUMENTS.

Extract from Notes on Mine-Surveying Instruments, With  
Special Reference to Mr. Dumbard D. Scott's Paper  
on Their Evolution,\* and its Discussion.\*\*

BY BENJAMIN SMITH LYMAN, PHILADELPHIA, PA.

Heller & Brightly's Improvements.— Messrs. Heller &

Brightly introduced several important improvements in the construction of the transit. See the report on them by the remarkably able committee of the Franklin Institute. The weight of the transit was diminished about one-half by using cast bronze, cast under great hydrostatic pressure—with a "high gate"—instead of hammered sheet brass, and by ribbing and bracing the plates, with the removal of superfluous metal. An experience of almost thirty years has now amply proved the wisdom of the change of metal, though the excessively conservative long maintained their doubts about so radical a departure from old practice. The method of attaching and detaching the instrument on the plate of the tripod-head, all corresponding to recesses in a flange around the exterior of the socket enclosing the compound centre, and one of the lugs being movable, so as to clamp the socket after turning the instrument until the lugs are away from the recesses in the flange. The tripod leveling-head was separately detached from the tripod. So detaching the transit proper, or level, with its long centre from the tripod leveling-head, and this head separately from the tripod, enables the instrument to rest securely in its packing-box in precisely the same way as it does upon the tripod-head. Though more difficult, it is a securer plan than the ordinary one, and makes it possible to carry the instrument safely to distant countries. Owing to the great reduction in the weight and to the readier method of attaching and detaching the transit from the tripod-head, the compound centre became feasible for ordinary use, instead of being virtually confined to the most accurate city- and tunnel-surveying. By degrees other makers have now adopted the same methods, so that the compound centre has at length become common everywhere; and the "flat centre" comparatively rare, with its friction between the plates, the quick wearing of the graduated plate around the shallow centre, and the consequent inaccuracy of work, and with the exposure of the spindle, or turning-centre of the entire instrument, whenever the transit is detached from the tripod-head.

\* Remarks on Mine-Surveying Instruments, p. 9 (Trans. Amer. Inst. of Mining Eng., xxxl.,—)  
\*\* Ibid., p. . . . (xxxl.,—)

Heller & Brightly also used a tangent-screw that overcame all lost motion, by means of a spiral spring that constantly presses the screw away from its supporting nut, not with the spring opening and closing to the extent of the whole motion of the screw, but merely to the extent of the backlash, by pressing against a detached follower within the nut. They extended the slits in the clamps on the axis of the telescope downwards almost to the bottom of the clamps, and made sighting-holes in the slits; so that an accurate sight at right angles to the

Fig. 159.

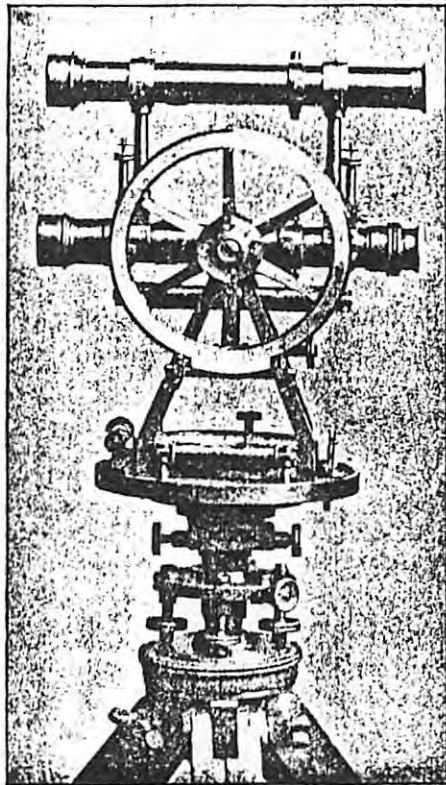

Heller &amp; Brightly's Mining-Transit.

telescope can be made. They made the tripod legs of semicircular cylinders sliding on one another's plane surface and clamping in any position; so as to give a play of from three to five feet in length of legs. The tripod-head and the cheeks for the legs were made of one piece; so as to prevent the possibility of unsteadiness there; and the top of each leg enclosed a single cheek, instead of being enclosed by two cheeks. Pure plumbago was used as a lubricant for all the screws, preventing hard work in cold weather.

One small device of theirs is a great convenience in setting the transit precisely under a plumb-bob hanging from the top of a mine gangway. For that purpose, a small screw in the centre of the top of the axle, or the binding-screw there that fixes the telescope in its axle, has a minute hole, say 1-32 in., or less, in diameter, by a special apparatus drilled in the top exactly in the centre of the axis of rotation of the transit. This form of the device dates back to about 1884; but from 1874, the same object was effected by a small brass plate with ad-

Fig. 160.

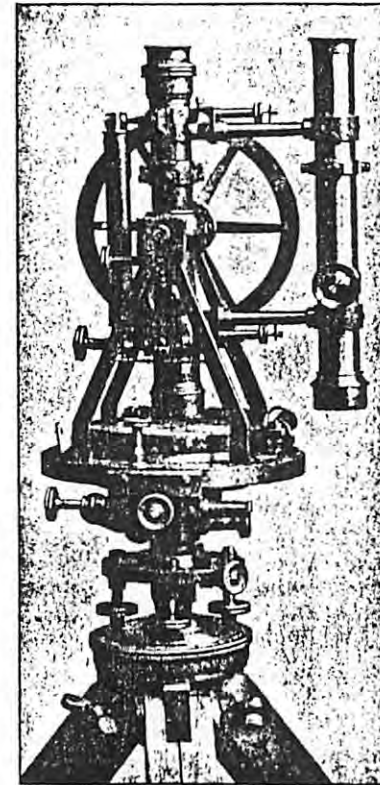

Heller &amp; Brightly's Mining-Transit

justing-screws, and with the centre marked by two lines crossing at right angles.

Heller & Brightly also constructed a mining-transit (Figs. 159 and 160), described by Dr. Raymond at our meeting of February, (Trans., Vol. I., p. 375). It was a close copy of their complete engineer's transit, but of reduced dimensions, making it the lightest American transit that had then been made. It had an erecting telescope 7¼ inches long, extreme diameter of plates, 5 inches; plate-graduation



circle,  $4\frac{1}{2}$  inches in diameter; a three-inch compass-needle; long compound centres; height of the instrument from the tripod legs, 7 inches; weight in all, about  $5\frac{1}{2}$  pounds; besides a tripod of  $3\frac{1}{2}$  pounds. At that time a prism and tube were provided to attach to the eye-piece of the telescope, for sighting vertically upward in shafts; but (as, notwithstanding Mr. Hoskold's argument\* that sighting a telescope up a shaft gives the same angular result as sighting down it, the sight cannot be equally satisfactory if water be dripping abundantly upon the up-turned object-glass) by —, a side-telescope was adjusted so as to be parallel to the central one, and was placed removably at the end of the main telescope axle opposite to the vertical arc. The effect of the eccentricity of the telescope can be corrected either by computation, or, more conveniently, by using a lop-sided or a double target. Mr. Hoskold\*\* speaks of Combes and "the use of his double target." But it does not appear that Combes ever used a double target, or even a lop-sided single one. The double target given by Scott in Fig. 23A\*\*\* appears to be of decidedly later date. Heller & Brightly later replaced the side telescope by an auxiliary top telescope, supported by two pillars, fore and aft, upon the main telescope; for the testing of the adjustment is far more convenient than with a side telescope, and a counterpoise, though quite feasible, yet so liable to be lost by a fallible mortal of a surveyor, is less necessary on account of the less serious effect of the weight of a top telescope, from its not tending to pull itself and the main telescope away from the correct vertical plane. The sights taken with the auxiliary telescope are, of course, comparatively very few, and at other times it is packed away with its pillars in the transit box, or in the surveyor's satchel, leaving the instrument wholly unincumbered and free from uneven wear of the centre, even if there be no counterpoise. In using a top telescope, the correction of the observed angle for eccentricity from the centre of revolution should not be neglected, especially in short sights; most conveniently by computation or by a small table. A small removable metallic reflector in the shape of a quadrant of a cylinder, to facilitate the reading of angles, was applied just behind the vernier opening; also there was a small adjustable lamp-stand easily fastened upon one leg of the tripod, and quickly set so as to illuminate the cross-wires of the verniers. These last attachments are likewise useful in astronomical observations with the larger transit, in determining the true meridian.

Such, at that time, revolutionary improvements in transits well deserved generous encomiums of Prof. J. B. Davis, of the University of Michigan, in describing Heller & Brightly's exhibits at the World's Fair. He says:

"I think their most valuable contribution to the advancement of their business is the spirit of invention and adaptation which they have awakened amongst their competitors. \* \* \* One is surprised at every point, in examining the work of this Philadelphia firm, to see the extreme care and judgment with which every detail is worked out. One cannot well help referring the work of other makers to theirs as a kind of standard with which to compare it."

\* *Rem. on Mine-Surv. Inst.*, p. 26 (*Trans.*, xxxi., —). \*\* *Trans.*, xxii., 972  
\*\*\* *Trans.*, xxviii., 706.

Indeed, it is quite incomprehensible how anybody in undertaking to write up "The Evolution of Mine-Surveying Instruments," with special allusions, moreover, to nearly every other surveying instrument directly or indirectly, even very remotely, connected with them, could have wholly failed to discover and mention an American establishment so prolific in important improvements in that line and so eminent in every branch of their business. The firm was established after the death of Wm. J. Young in July, 1870. The head and soul of the firm, Mr. Charles S. Heller, had been fifteen years with Mr. Young, the last five years of Mr. Young's life as his only partner. Mr. Brightly was one of their most skilful workmen. Mr. Brightly retired from the firm in 1889, and died in 1893.

#### Improved Method of Measuring in Mine Surveys.

In making surveys in the anthracite coal regions of Pennsylvania, the ordinary engineer's chain (50 or 100 ft. long) is generally used, both above and below the ground. Sometimes, where it is difficult to chain, as, for instance, across a chasm, a wire is stretched from one station to the other, the distance is marked on the wire and its length is then measured with the ordinary chain. Having had occasion lately to make some surveys where it was necessary to determine with great accuracy the position of the land or property line, not only in the gangways or levels, but also in the breasts or chambers, the coal on the north side of the line belonging to one party and that on the south side to another, and as it is very difficult to measure up the breasts or slopes with accuracy, and to make the proper allowance for the pitch of the vein (the true horizontal distance being, of course, the product of the distance measured with the chain by the cosine of the angle of inclination of the chain), and as the ordinary method of chaining up or down steep slopes on the surface, by holding a portion of the chain horizontal and plumbing down from the high end, would in most cases be very difficult and dangerous, and sometimes impracticable, I determined to adopt a new plan which would do away with most of the above difficulties, and by which I could eliminate many causes of error from my ordinary chaining.

My first idea was to have a fine steel wire rope, about 300 ft. long, stretched as much as possible in making, so as to do away as well as I could with that source of error, and then to have it graduated every ten feet. I proposed using small brass tags of different shapes to designate the different hundred feet thus:

- 100 a triangle.
- 200 a square.
- 300 a circle, etc.

The numbers of the ten feet spaces were to be marked by drilling small holes in the tags. I intended to use this for the principal lines of my surveys and to use the chain only for lines which were not of great importance.

When I called upon Mr. Heller (of Heller & Brightly, the instrument makers, of Philadelphia,) to order this measure, he suggested that it would be better to use instead of a wire rope, which would stretch, the bands which are manufactured for hoop skirts; they are made of tempered steel, are very light, and will not stretch sensibly. After consultation with him, I decided to have the tape measure constructed which is now before you. It is 500 ft. long and weighs 2 lb. 7½ oz. It is a ribbon of tempered steel, 0.08 inch wide, 0.015 inch thick. At each 10 feet a small piece of brass wire is soldered across the tape, the solder, which is white, extending about one inch on each side of the wire. In the latter, a small notch is filed, which marks the exact point where the ten feet ends. The exact distances from the zero point of the tape are marked upon the solder by countersunk figures. The white solder enables one to find the ten feet notches very easily, and, no matter how dirty the tape may be, by wiping off the solder with the finger, the distances are easily read, as the countersunk figures, being filled with dirt, stand out upon the white ground of the solder. The 0 and 500 feet marks are not at the end of the tape, but near it, and are also denoted by a notch filed in a wire soldered to the tape.

The tape is wound upon a simple wooden reel, ten inches in diameter, which is held in one hand and turned by the other. At first some difficulty is experienced in winding up the tape, but a little practice soon overcomes it. Two brass handles, which can be detached, accompany the tape and are carried upon the reel.

*Description of a survey made with the tape.*—The instruments used were one of Heller & Brightly's new 11-inch transits, \* 2 plummet lamps, the 500 ft. tape and a 5 ft. wooden rod divided into feet and tenths. The latter is used to measure the distance from the nearest ten feet to the station. There were two closed sets of lines or surveys, one set entirely above ground, but through the swamps and brush of the anthracite coal region, and one partly above ground and partly in the mines. The latter began at a point in the swamp, went overground 2400.57 ft. to the mouth of the slope, then down the slope (pitch 37 deg.), 276.99 ft. (horizontal distance), then along the gangway 4272.01 ft. which formed one-half of an ellipse, then up through a breast (pitch about 34 deg.) 275.44 ft. (horizontal distance) to the bottom of an air shaft, then by two plumb lines to the surface, and then through the swamp 141.83 ft. on the surface to the point of beginning. The length of the periphery of the first closed figure was 6660.19 ft.; that of the second 7366.84 ft. Tables I. and II. show the details and calculations of the two surveys:

\* Five inch Magnetic Needle. Telescope, 10¼ inches long. Telescope erecting and magnifying, 28 diameter.

TABLE I.

Station	Angle		Reduced Angle	Distances	Positive Sine	Negative Sine	Positive Sum of Sines	Negative Sum of Sines	Positive Cosine	Negative Cosine	Positive Sum of Cosines	Negative Sum of Cosines
	Right	Left										
1	0°04'		0°04'	661.07	0.78		0.78		664.75		664.75	
2	0°47'		0°51'	711.55	10.56		11.31		711.47		1376.22	
3		0°52'	0°01'	408.00		0.12		11.22	408.16		1784.38	
4	0°23'		0°12'	567.25	6.28		16.50		567.22		2351.60	
5				186.06		3.24		13.26		184.02	2165.58	
6	179°32'		179°00'	88.42	44.48		67.74			76.42	2889.16	
7	31°12'		21°012'	889.50	297.72		355.46			251.15	1838.01	
8	19°39'		23°061'	631.00	643.41		898.87			820.73	1517.28	
9	9°38'		23°027'	381.25	313.62		1212.49			216.77	1300.51	
10	4°06'		23°021'	752.50	260.37		1462.86			709.63	590.88	
11	35°55'		19°026'	294.80		201.87	1260.99			214.84	376.04	
12	62°39'		13°047'	527.20		296.33	904.60			438.04		60.00
13		9°01'	145°48'	464.85		399.91	664.75		236.97			
14	88°27'		59°21'	210.65		204.14	860.61			49.86	176.07	
15		44°17'	103°38'	882.20		360.82	-0.29			127.47		
16		6°51'	109°29'									
17					1466.22	1466.93				2588.57	2588.57	
18					Difference +0.29					Difference 0.00		

TABLE II.

B	31°12'	-21°012'	88.42	44.48	57.74		76.42	2889.16	
H1	19°39'	-23°061'	389.50	297.72	855.46		251.15	1838.01	
H2	9°38'	-23°027'	631.00	643.41	898.87		820.73	1517.28	
H3	4°06'	-23°021'	381.25	313.62	1212.49		216.77	1300.51	
H4	35°55'	-19°026'	752.50	260.37	1462.86		709.63	590.88	
H5	31°20'	-16°006'	157.90		32.56		1430.80		
O	73°10'	-9°057'	278.99		276.96		154.34	28.90	412.47
1	88°44'	-6°13'	651.98		70.60		1083.74	648.29	1080.76
2		11°35'	17°48'	187.06	48.01		1035.73	149.54	1210.30
3	6°41'	-11°07'	281.60		64.28		981.45	276.22	1488.52
4	8°21'	-2°46'	86.90		4.19		977.28	86.79	1673.31
5		0°26'	12°12'	192.91		40.77	936.49	188.55	1761.86
6		4°31'	16°43'	208.12		59.86	876.68	198.88	1900.72
7		2°17'	14°20'	235.85		68.79	817.84	228.40	2189.12
8		7°35'	21°59'	476.32		178.30	639.54	411.68	2630.80
9	4°09'	-17°02'	101.20		31.05		694.40	96.92	2727.12
10		7°50'	25°18'	235.64		102.60	505.33	212.15	2839.27
11	18°50'	-6°58'	370.85		44.98		460.95	308.11	3307.38
12		51°40'	68°44'	80.40		73.85	387.10	44.84	3352.23
13		44°30'	103°14'	99.95		97.30	289.80		3320.34
14		78°51'	182°05'	316.50	11.51		301.31	22.88	316.30
15	14°59'	-17°006'	161.38		33.80		267.51	147.56	3013.04
16	13°08'	-153°38'	107.95		47.88		230.18	97.00	2965.48
17		15°30'	169°28'	123.36		22.55	197.58	121.29	2708.48
18		13°15'	182°43'	209.60	9.93		207.51	298.37	2647.19
19		4°40'	187°23'	178.54	28.00		230.51	177.65	2437.82
20G	68°10'	-12°018'	21.91		16.98		213.63	18.85	2250.17
F	24°44'	-10°029'	173.71		167.56		45.97	18.85	2236.32
E	34°10'	-7°019'	79.82		73.79			48.44	2202.88
D	21°50'	-48°20'	9.08		6.78				2229.27
C		19°08'	25.95		23.97				2245.31
A		164°40'	106.60	71.81					2215.25
B	48°17'	-22°14'							2160.20
					1665.85	1665.87			
					Difference -0.02				
							2882.12	2881.50	
							Difference +0.82		

From these we see that the total errors were in the

	Sine.	Cosine.
First case.....	+0.29	0.00
Second case.....	-0.02	+0.62

This is very accurate work, for this kind of mine surveying. We made three other surveys on the same property with equally good results.

In measuring with the tape it is better to have at least three men, one at each end and one to take off the distances and note them. The hind chainman should be a reliable man, as he must hold the zero point of the tape exactly at the nail in the stake, or alongside of the cord to which the plummet lamp is suspended. The front chainman has merely to stretch the tape and to see that it passes exactly over the front station. The third man, who carries the five foot rod, starts from the rear station and notes the distances of the breasts, etc., as he goes along until he arrives at the forward end, where he notes the distance of the station from the last one. In measuring distances of over 500 feet, a temporary station is made at 500 feet exactly in the line to be measured.

*Advantages of the tape.*—First, greater facility in measuring up or down slopes, breasts, etc. Second, greater accuracy in measuring from one station to another, as the tape forms a straight line from one station to another, and as there is no error from the use of pins. Third, the tape does not stretch appreciably.

*Disadvantages.*—First. It is liable to break unless carefully handled. Second. It is necessary to roll it up and unroll it, when the distances between stations vary much.

The tape can be easily mended by any watchmaker when it breaks, and Messrs. Heller & Brightly make a small sleeve of brass, tinned inside, in which the ends of the tape, when broken, are slipped and then soldered fast by merely heating the sleeve with a red hot poker. They also have little brass clamps to fasten on the tape to mark any point which is to be used several times.

When the men become accustomed to the tape they wind it up and unwind it very quickly.

There are three sources of error which may be referred to, viz.:

- I. The extension of the tape by stretching.
- II. The shortening of the tape in consequence of the tape assuming the form of the catenary curve.
- III. The contraction or expansion due to the change of temperature.

As stated above, the tape does not stretch appreciably, but this error being in the opposite direction is, to a certain extent, compensated for by the shortening due to the formation of the catenary curve by the tape. I subjoin a table, calculated by my assistant, Mr. Edgar Kudlich, showing the shortening of the tape due to the latter cause. The tension in practice is from 30 to 40 pounds.

TABLE III.

Length of Tape Measure	True distance when tape is subjected to a tension of (or chord of the catenary curve formed by a tape).					
	10 lb.	20 lb.	30 lb.	40 lb.	50 lb.	60 lb.
100 feet .....	99.9804	99.9074	99.9888	99.0993	99.9996	99.9997
200 feet .....	199.9153	199.9791	199.9907	199.9918	199.9967	199.9977
300 feet .....	299.7143	299.9294	299.9687	299.9824	299.9887	299.9922
400 feet .....	399.8208	399.8327	399.9260	399.9583	399.9738	399.9815
500 feet .....	499.6775	499.6732	499.8551	499.9185	499.9479	499.9638

According to the table given by Haswell for the expansion of steel, a tape measure 500 feet long at 32° Fahr., would become 500.6 feet long at 212°, so that a variation of 60° in temperature would only cause a variation of two-tenths of a foot in a 500 feet tape.

In conclusion, I would advise the use of the tape for all important work, while the chain should be used for filling in details, and where accuracy is not absolutely necessary.

## DISCUSSION.

Mr. Coxe remarked, in answer to questions, that no correction was applied for temperature, and no allowance for stretching of the wire ribbon. He thought its extension was practically *nil*.

Mr. Raymond commented on the fact that, while mining and surveying instruments of all kinds had been improved so much in recent years as regards accuracy and precision, the method of measuring distances—the chain—had remained the same. Nothing could be inherently more objectionable as a standard of measurement than a chain composed of links which are liable to wear by friction.

Heller & Brightly's Sunflower (with Quick-Leveling Tripod and Extension Legs)  
An Instrument for Making Cross-Sections of Tunnels, also for Testing  
Masonry Work after the centres are struck

## THE SUNFLOWER.

Or Disk For Measuring Cross-Sections in Tunnels.

[From "The Transactions of the Croton Aqueduct Commission."]\*

The ordinary practice of measuring the sections of a tunnel is often slow and tedious, particularly so when it is necessary to repeat them every ten feet or less, in a tunnel having a large sectional area; but to reduce this labor to a minimum the disk-measure was designed for the New Croton Aqueduct, where it is generally known as the "Sunflower." It is also useful for testing masonry work after centres are struck, to note if any settlement or distortion has taken place.

This instrument consists of a disk firmly secured to cross-pieces of wood, supported by braces *c*, which are riveted to the tube *d*. This tube, when placed in position on tripod-head, can be moved vertically, and secured to any height desired by the clamp-screw *A*. The disk *a*, and cross-pieces *b*, and "indicating-arm" *e*, are made of wood, but all other parts are brass.

Figure 1 is a vertical section through the "Sunflower," *a* being the disk, which is  $\frac{1}{4}$  of an inch thick and 14 inches in diameter, firmly secured to cross-pieces *b*, which are  $2\frac{1}{2}$  inches wide and  $\frac{3}{4}$  of an inch in thickness. Figure 3 represents back of disk and frame, and to the latter a circular band, *g*, is fastened with screws. This band is  $\frac{1}{8}$  of an inch thick and  $\frac{3}{4}$  of an inch wide. The vertical and horizontal braces *c*, in Figs. 1 and 4, are secured to this band at *i* in Fig. 3. The space between disk and vertical tube *d*, to which the braces are riveted, is  $2\frac{5}{8}$  inches. This tube is  $\frac{3}{4}$  of an inch in diameter and three feet long. The face of disk shown in Fig. 2 is graduated into degrees, from  $0^{\circ}$  to  $180^{\circ}$ . Bearing plates are inserted on face and back of disk at axis shown by black lines at *k*, Fig. 4.

Figure 4 is a horizontal section on an enlarged scale of *a*, *b*, and braces *c*, with the form of connecting the latter with the tube *d* at *h*. In Fig. 2 the dotted lines show the relative position of "indicating-arm," which is represented on plan at *e*, Fig. 1, detached from section. At each end of this "arm" brass plates project to aid in guiding the rod used in measuring the distance from the axis of the disk to the perimeter of the tunnel section. A vernier is marked on the "indicating-arm" for reading distances less than half a tenth when desired for testing masonry work.

At the axis of the "indicating-arm" *r*, a solid piece of metal is firmly secured to the "indicator," and extends through to the back of the disk, where it is held in position by the spring *s* and a capstan-headed nut. This "indicator" is raised  $\frac{1}{8}$ -inch from the disk by a shoulder, permitting it to revolve freely. In Fig. 3, *s* is a plan of a

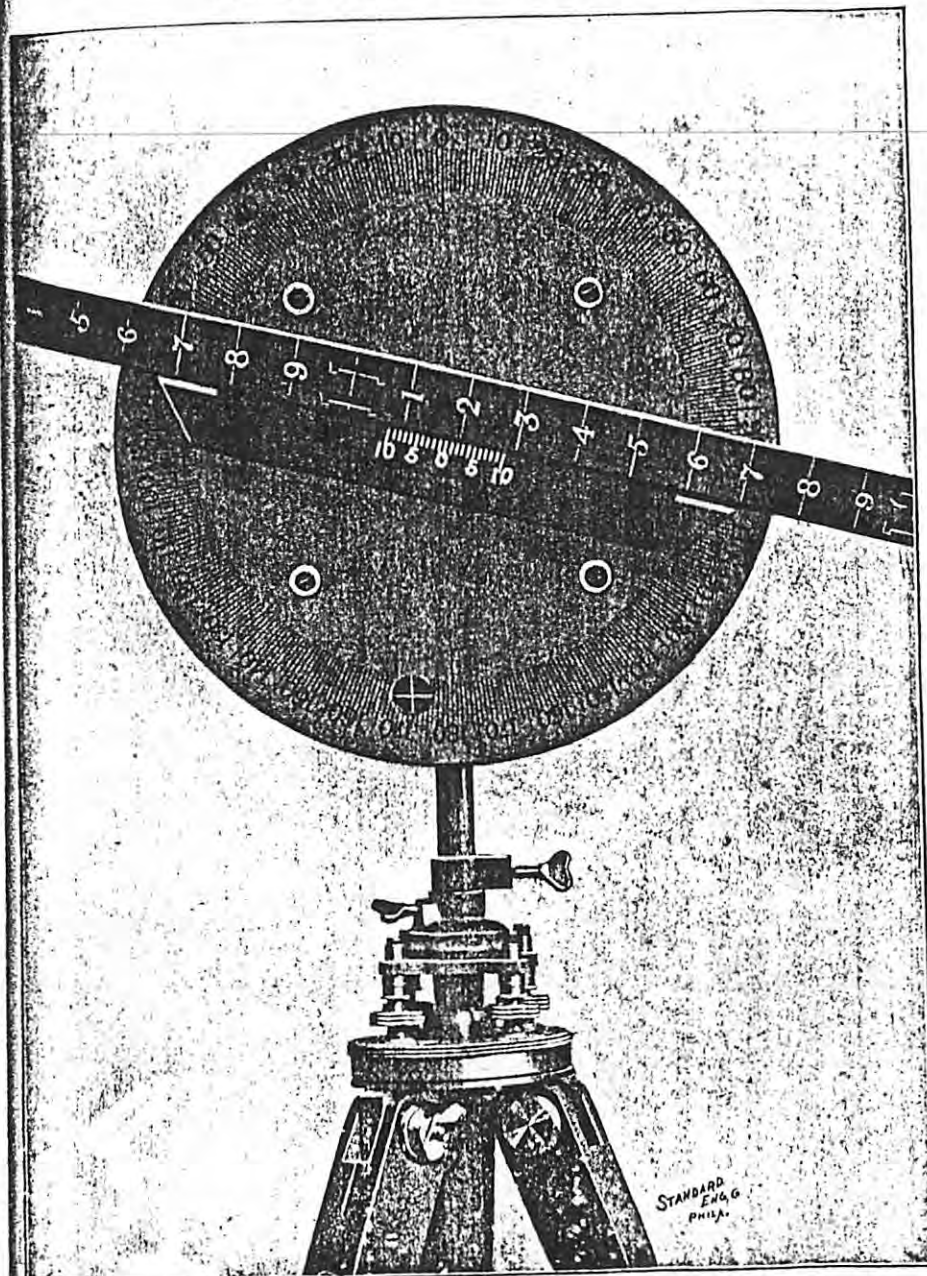

Made by Heller & Brightly, Philadelphia, Pa.

\*This Report of the Commission was also printed in *The Sanitary Engineer and Construction Record*, New York.

Heller & Brightly's Sunflower (with Quick-Leveling Tripod and Extension Leg)  
An Instrument for Making Cross-Sections of Tunnels, also for Testing  
Masonry Work after the centres are struck

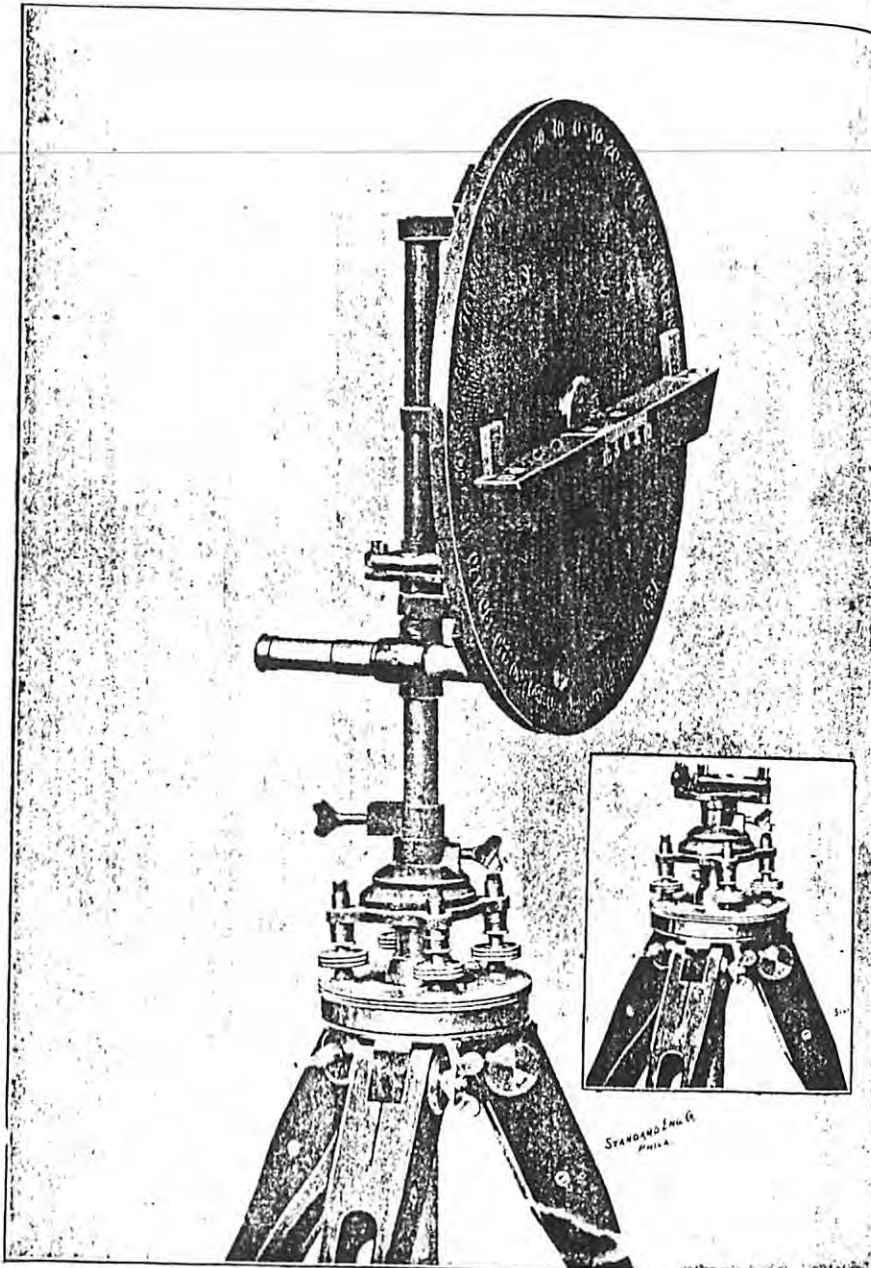

Made by Heller & Brightly, Philadelphia, Pa.  
The small figure shows the Removable Leveling Arrangement

Heller & Brightly's Sunflower (with Quick-Leveling Tripod and  
Extension Leg)

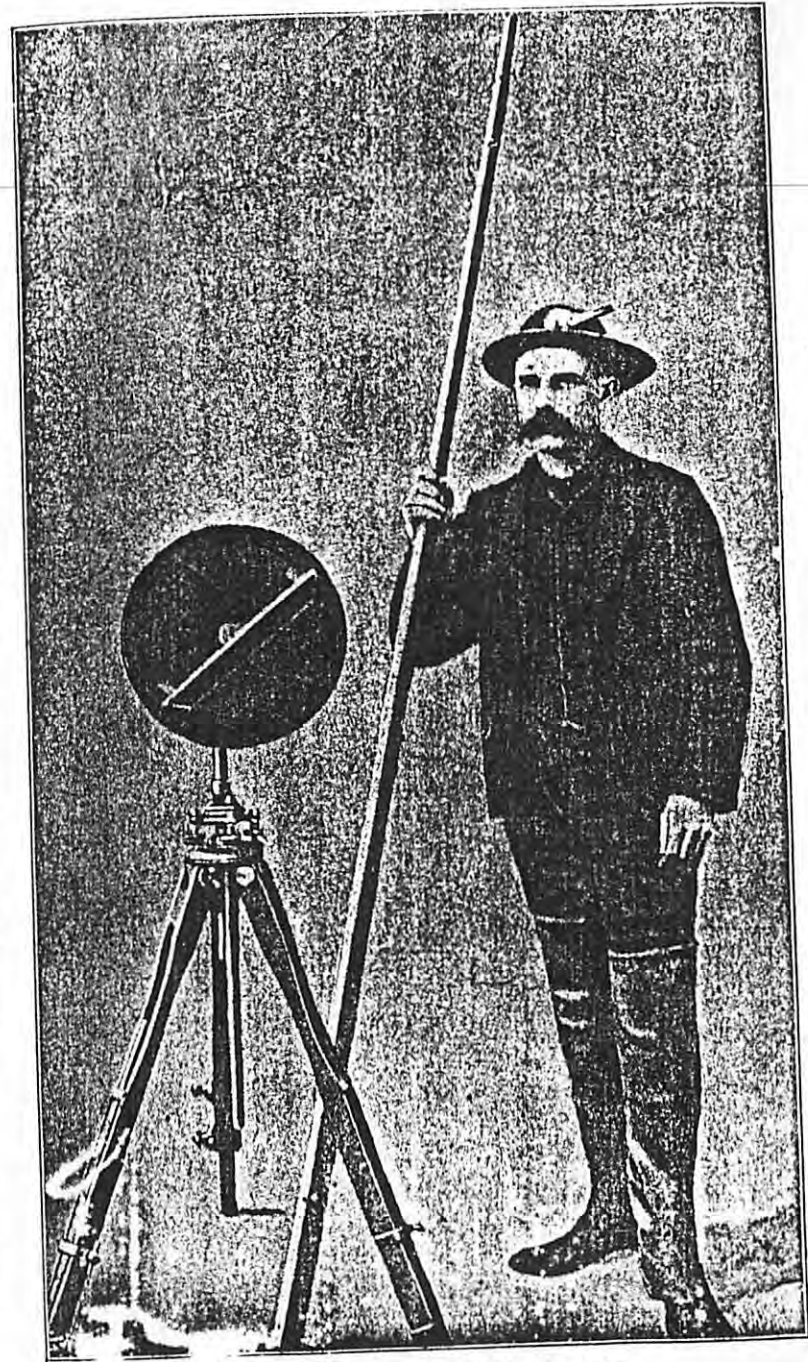

Made by Heller & Brightly, Philadelphia, Pa.

spring and capstan-headed nut. At *f*, Fig. 1, a longitudinal section of a "sight-tube" is shown, which consists of a plain tube with a small hole at *f* in the eye-piece, and vertical and horizontal cross-wires at *j*. Over this sighting-tube the leveling-bubbles are placed at *l*, and in plan on Fig. 6. Under the sighting-tube can be seen the clamp-screw A, which

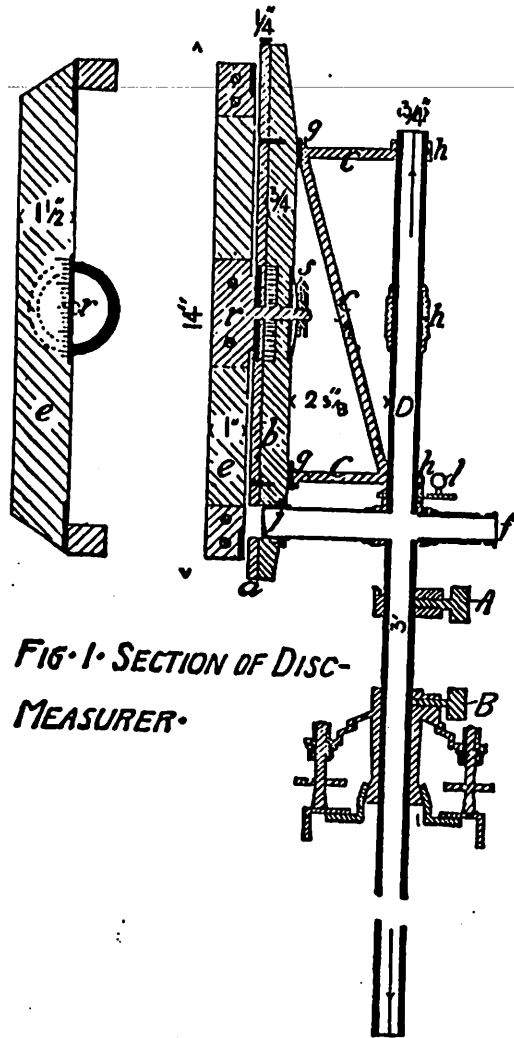

FIG. 1. SECTION OF DISC-MEASURER.

is movable on the tube *d*. When the Sunflower is set in position, this clamp rests on the tripod-head, and the disk can be raised or depressed to any desired height.

The clamp B is shown on the enlarged section of the tripod-head, Fig. 5. The black lines at *m m* represent a detached piece of metal,

which is in horizontal section about 1-32 inch less than a complete circle, thereby permitting the clamp B to secure the tube *d* in a firm position when the disk is set on the centre axis of the tunnel in position for measuring sections. The ball-and-socket joint is also shown in Fig. 5.

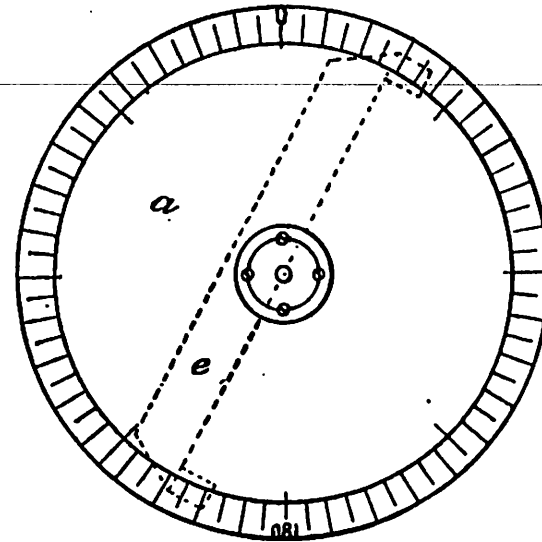

FIG. 2. FACE OF DISC.

Figure 6 is a section of a quick-leveling socket and a plan of the leveling bubbles.

This socket is a tube 5 inches long, closed at the lower end, except a small hole, which is to allow a cord to be passed through, to which a plumb-bob can be attached.

Two measuring rods are furnished, made of pine, one being 8 feet and the other 14 feet long, 1 inch wide and  $1\frac{3}{8}$  inches in depth, made tapering in depth only from the centre to  $\frac{5}{8}$  of an inch at one end, to lessen the weight, having a metal shoe on the taper end to prevent injury when pressed against the rock face of the tunnel. The rods are divided in feet and tenths.

#### DIRECTIONS FOR USING SUNFLOWER.

The centre line of the tunnel is not preserved on the floor, where constant travel would disturb it, but by drilling holes in the roof about 50 feet apart. Into these holes pine plugs  $1\frac{1}{2}$  inches in diameter and 4 inches long are driven, and into each plug a horseshoe nail (with head flattened and having a centered eyelet), is inserted. Through the eyelets, telegraph wire is suspended vertically from two plugs, and kept in position by weights of about 25 pounds each. (a stone will do). A

horizontal wire can then be stretched between these two vertical ones, and will produce a line close enough for rock sections. Over this horizontal wire a tripod which has extension legs is set, with the disk detached. The tripod is then made plumb and leveled by inserting the

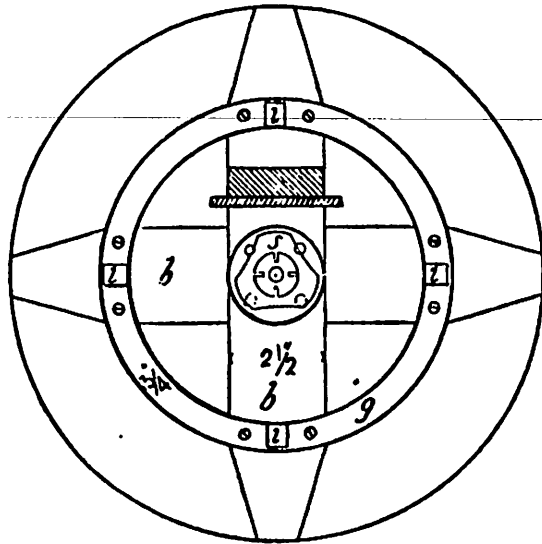

FIG. 3. BACK OF DISC.

quick-leveling socket shown in Fig. 6. When this operation is completed, the leveling-socket is removed, and the tube *d* is placed in position in the tripod head, and the disk raised to the required elevation by sighting through the sight-tube to a leveling-rod held on the bench, and then fixed firm in elevation by the clamp-screw A.

The sight-tube is then turned in the direction of the vertical wire

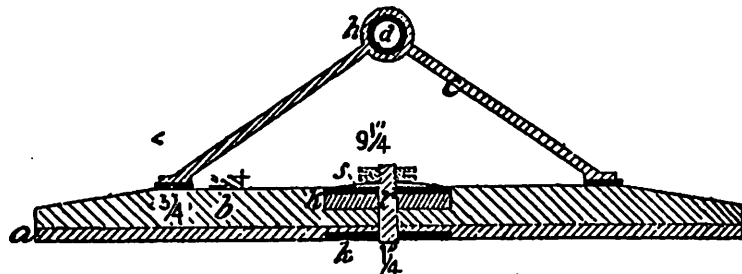

FIG. 4. SECTION THROUGH DISC & HORIZONTAL BRACES

in advance of the instrument, which can be readily seen by the use of a lamp for that purpose, and fixed in position by the clamp-screw B. The disk will then be on the centre line, and in position at right angles with the central axis of the tunnel. When more accuracy is required the line

can be taken with a transit. The Sunflower is now ready for taking sections. The "indicating-arm" is set at 0°, and the measuring-rod (previously described), resting on the indicator, is extended to the perimeter of the section, and the distance is recorded. Then the indicator is moved to the next angle, the distance and angle recorded; this operation being repeated from 0° to 180°, when the rod is reversed and the opposite half of the section measured in the same manner. A copy of a field record is shown in Table II, and the plotting of the field notes illustrated in Fig. 8. The plotting can be done with any protractor.

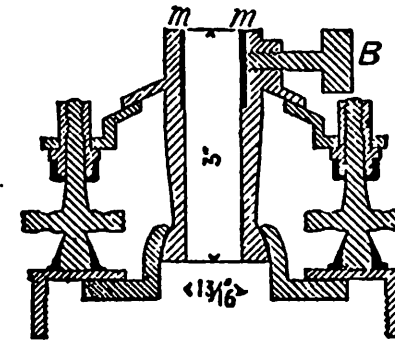

FIG. 5. ENLARGED SECTION THROUGH TRIPOD HEAD.

Table I is the form used in the field books for recording the location of plugs driven in the roof of the tunnel for alignment. The first column is the station; the second, the number of the plug; the third, the elevation; the fourth, the roof grade, which is twelve inches above the intrado of the arch; the fifth and sixth columns, the height of the plug above or below this grade; the seventh, the name of person setting the plug; the eighth, the date; the ninth, the distance from the centered line.

TABLE I.

LIST OF THE PLUGS IN THE TUNNEL NORTH OF SHAFT NO. 29

Station	No.	Elevation	Roof grade	Hght	Low	Set by	Date	From line	Remarks
1482+40.19	16	177.47	147.29	3.18	.....	C. T. F.	1885 June 8	.....	Centre of shaft.
1481+85.7	17	185.38	183.37	2.01	.....	C. T. F.	June 8	.....	
1481+31.76	18	192.42	191.46	0.96	.....	C. T. F.	June 8	.....	
1481+98.74	19	184.397	196.41	1.99	.....	M. C.	June 12	.....	Inside of shaft
1481+83.00	20	345.77	292.97	2.91	.....	C. T. F.	June 12	.....	
1479+87.48	21	213.50	213.10	0.20	.....	H. C.	June 12	.....	Screw blown out
1479+49.48	21	218.282	217.48	0.80	.....	M. C.	Aug. 13	.....	

Table II represents a record of notes taken for rock excavation measured at two sections in the tunnel, with date and station of cross-section. The first and second columns give the angle and distance from centre of the disk to the perimeter of the cross-section on the east side; the second and third columns, a similar record for the west half of the cross-section. Left and right can be used in place of east and west to designate the division of the cross-section, but the latter is preferred, as it eliminates any doubt of the direction a field party may have been working-in when taking the cross-sections, as the axis of the tunnel extends in a northerly or southerly direction. The note below the table, "Axis 2.2 below spring," indicates the elevation of the centre of the disk when the cross-sections were taken. The area of the cross-section can be correctly measured by setting the Sunflower at any point within the plane of the cross-section. Some engineers prefer to set the centre of the disk at a uniform elevation above or below the spring-line to give uniformity of the working-line, as ordinates can be calculated, giving the distance to the perimeter of section, a reference to which at the time of taking cross-section will determine if the excavation has conformed to the section required.

TABLE II.

November 18, 1886.				December 27, 1886.			
Station 1483+20.				Station 1482+20.			
EAST.		WEST.		EAST.		WEST.	
Deg.	Dist.	Deg.	Dist.	Deg.	Dist.	Deg.	Dist.
0	9.7	15	10.2	20	13.0	0	14.8
15	9.9	32	10.7	34	12.7	18	11.9
36	10.5	47	10.3	50	10.4	36	11.8
53	9.5	60	9.0	70	10.1	51	10.8
70	8.1	79	7.5	86	9.1	68	9.6
85	7.1	105	6.7	99	8.2	82	8.5
105	7.0	123	6.7	117	7.9	90	8.3
129	6.8	145	5.7	140	6.7	110	7.4
150	5.4	165	5.0	.....	.....	125	6.4
180	4.9	.....	.....	.....	.....	150	5.2
----	----	.....	.....	.....	.....	180	4.8
Axis 2.2 below spring of arch.				Axis 2.4 below spring of arch.			

Figures 8 and 9 represent the notes recorded in Table II, plotted to facilitate a correct computation of the areas. The form of the printed sheets used for that purpose is given in Fig. 8, with the angle of each measurement computed from the note given in Table II. All sheets for this purpose are printed on a scale of 20 feet to 1 inch, the same scale as the arm of the protractor that is used for plotting. The axis

from the spring-line is first marked on a sheet, then the centre of protractor put in position over it and pressed firmly down, which will project the pins through the paper and keep it in position, permitting the arm which revolves around the centre to be moved quickly to any point desired for plotting the notes of the cross-sections.

In Table III the field notes plotted on Fig. 8 are arranged for computing, the number of shaft, heading station and date of measurement being recorded. It is separated in two divisions, one for the east and the other for the west half of the section. The first column contains the numbers which designate the angle taken, and the second the factors required to compute the area of a triangle, which are the length of two

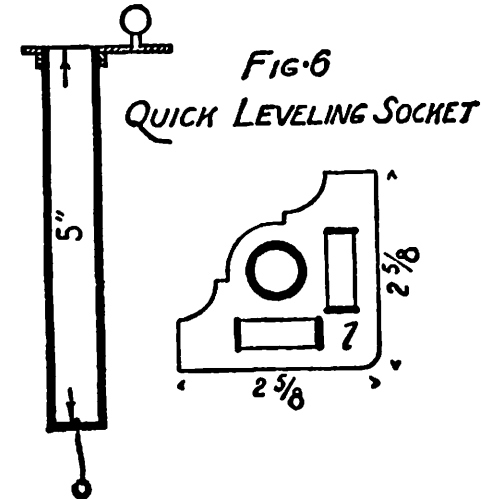

sides and the included angle; the third column, the logarithm of the factors; and the fourth, the area. The westerly half is calculated in a similar manner; the amount of the two added together and divided by 2, will give area of the whole section. To diminish the labor of taking off the logarithms, two tables are prepared on separate sheets, one containing the copy of the logarithms of numbers from 1 to 20.9, advancing by tenths, and the other the logarithmic sines from one to sixty degrees, advancing by single degrees. The sheets in size are 8x10 inches. The sheet to contain the logarithms of numbers is divided into twelve columns, the ten intermediate columns being headed by the numerals 1 to 10, the first and last containing decimals 1 to 10, and the ten columns between containing the logarithms. The sheet is separated into two parts, permitting the logarithms from 11 to 20 to be entered on the lower half.



On the other sheet is copied the logarithmic sines from one to sixty degrees. This is divided into eight columns, with the angles and sines placed in alternate columns. If the field notes are carefully plotted on the section sheets, the area can be computed quickly with a planimeter, and the variation from the correct area will be less than two-tenths for the whole section. The time required to measure a section of the tunnel

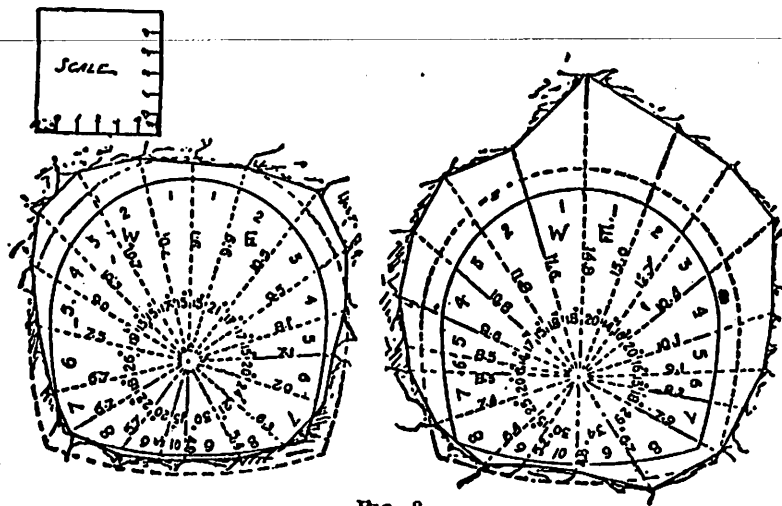

FIG. 8.

with the "Sunflower" is from six to ten minutes. It was designed by Alfred Craven, a division engineer on the aqueduct. The weight of the disk, including all attachments, is ten pounds, and the tripod head, with the tripod, having extension legs,  $10\frac{1}{4}$  pounds, making a total of  $20\frac{1}{4}$  pounds. It is manufactured by Heller & Brightly, of Philadelphia. Two measuring-rods, eight and fourteen feet long, go with the instrument.

### The Sunflower Tunnel Cross-sectioner.

From the Engineering News

As engineers well know, the testing, or cross-sectioning, of tunnel work is a tedious operation under ordinary methods and where accuracy is required. In the construction of the Croton Aqueduct, Mr. Alfred Craven, M. Am. Soc. C. E., and now Division Engineer for the Aqueduct Commission, suggested a form of instrument for this work that has been put upon the market by Heller & Brightly, instrument manufacturers, of Philadelphia, Pa. The original instrument employed on the Croton Aqueduct was fully described in *Engineering News* of July 26, 1890, but its design and construction have been modified considerably, as will be seen by comparing the accompanying illustration with that published in our previous article. For this reason, and also because it is an unusually compact and convenient device for its purpose, we describe it briefly in this issue. (For illustrations, see pp. 53 and 54.)

The prominent feature of the instrument is a wooden disk, 14 inches diameter and  $\frac{1}{4}$  inch thick, braced at the back to prevent warping; and from this disk the device takes its trade-name of "Sunflower." This disk, graduated on the front to degrees, numbered from 0 to 180, is supported vertically by a tubular rod, on an extension-leg tripod fitted with a quick-leveling head. Attached to the centre of the disk is a revolving, metal shod, wooden "indicating arm," and on this arm slides a graduated tapering wooden rod either 8 or 14 feet long. These rods, however, may be of any length. Those used on the Rapid Transit Tunnel, in New York, are 20 feet long. Through the disk and attached to the tubular support is a horizontal sighting tube, with cross-wires, which enables the user to set the centre of the disk accurately upon the tunnel axis.

In use, the tubular support is set exactly plumb by two small levels at right angles to each other. The disk can then be adjusted to any height and secured by clamp-screws; and with its centre upon the tunnel axis, the measuring rod (placed on the indicating arm) measures the distance between the centre of the disk and the perimeter of the tunnel at as many points in that plane as may be desired.

The disk with its attachments weighs 10 pounds, and the tripod and its head weigh  $10\frac{1}{4}$  pounds, making  $20\frac{1}{4}$  pounds of total weight. In the Croton Aqueduct tunnels from 6 to 10 minutes were sufficient for measuring a section. As the angles and distances are conveniently plotted with a protractor, the area can be measured with a planimeter. This device is also useful for testing masonry arches after the centres are struck, and for this purpose a vernier is placed upon the indicating arm for more precise measurement.

TABLE III.

SHAFT No. 29—HEADING STATION 1483 + 20.

EAST SIDE.			WEST SIDE.				
△	Factors.	Log.	Double Area.	△	Factors.	Log.	Double Area.
1	9.7	0.98677	24.854	1	9.7	0.98677	25.609
	15°	9.41300			15°	9.41300	
	9.9	0.99564		10.2	1.00860		
		1.39541			1.40837		
2	9.9	0.99564	37.252	2	10.2	1.00860	31.901
	21°	9.55433			17°	9.46594	
	10.5	1.02119		10.7	1.02938		
		1.57116			1.59392		
3	10.5	1.02119	29.161	3	10.7	1.02938	28.524
	17°	9.46594			15°	9.41300	
	9.4	0.97772		10.3	1.01284		
		1.46485			1.45522		
4	9.5	0.97772	22.498	4	10.3	1.01284	20.852
	17°	9.46594			13°	9.35209	
	8.1	0.90849		9.	0.95424		
		1.35215			1.31917		
5	8.1	0.90849	12.937	5	9.0	0.95424	21.976
	13°	9.35200			19°	9.51264	
	7.1	0.85126		7.5	0.87506		
		1.11184			1.34194		
6	7.1	0.85126	16.998	6	7.5	0.87506	22.028
	20°	9.53405			26°	9.64184	
	7.0	0.84510		6.7	0.82608		
		1.23041			1.34298		
7	7.0	0.84510	17.937	7	6.7	0.82608	13.868
	24°	9.60931			18°	9.48998	
	6.3	0.79934		6.7	0.82608		
		1.25375			1.14204		
8	6.3	0.79934	12.191	8	6.7	0.82608	14.306
	21°	9.55433			22°	9.57358	
	5.4	0.73239		5.7	0.75588		
		1.08606			1.15554		
9	5.4	0.73239	13.230	9	5.7	0.75588	9.747
	30°	9.69897			20°	9.53405	
	4.9	0.69020		5.	0.69897		
		1.12156			0.98890		
		187.058		10	5.0	0.69897	6.340
		195.149			5.0	9.41300	
		2)382.207		4.9	0.69020		
		Total Area, 191.103			0.80217		195.149

## THE HELLER &amp; BRIGHTLY SURVEYING INSTRUMENT.

## A Commentary.

Heller & Brightly instruments are the result of half a century specialized manufacturing of higher grade transits and levels.

They are built with one object in mind—"Service." They are the exponent of accuracy and durability. One H. & B. transit sent the other day for repairs was made in March, 1871, forty-four years ago. This remarkable old "veteran" is still on the job and as strong, substantial and accurate as ever.

Close inspection keeps H. & B.'s up to their high standard. If you were to offer us much more than the present price, the quality of materials and workmanship could not be improved.

Having no salesmen or agency stocks to increase the selling price, this saving is placed in H. & B. instruments to the benefit of the user.

Such a plan further guarantees that the purchaser receives direct from the manufacturer an H. & B. instrument that is absolutely fresh in finish and perfect in adjustments, without the deterioration incidental to agency consignments.

Such constructional features as sterling silver graduations; complete sets of dust and rain guards; hard, red brass for composing parts; German silver tangent screws, etc., materially increase manufacturing costs, but mean increased service and accuracy.

There is an H. & B. for every purpose—tested and proven. Over 80 per cent. are sold on repeat orders, showing their remarkable success. Engineers of wide experience in the field not only value the accuracy of graduations and great range of telescope, but endorse H. & B. instruments for permanency of adjustments and close needle, stadia and leveling work.

If we can furnish you with any information gathered from our experience as manufacturers which will be valuable to the engineering profession at large, or help you in any way to solve your instrument buying problem, we ask you to write us.

## GENERAL CHARACTERISTICS OF HELLER & BRIGHTLY INSTRUMENTS.

As an introduction to the following descriptions of H. & B. instruments, a few remarks are necessary on their constructional and stock features.

### Constructional Features.

**The Exclusive Detachable Leveling Head.** H. & B. transits and levels are all of this type. The leveling head is detachable from both transit proper and from tripod head. It may be left on head or slipped into its proper place in carrying box when not in use. The union clamping arrangement is rigid and well constructed. The transit can be taken off or put on without disturbing any of the permanent adjustments. When together it is as rigid and strong as any affixed type could possibly be.

The advantage of the detachable leveling head is in its convenience. H. & B. instruments can be set up and leveled before the fixed type with its sliding base is hardly clear of the box. This arrangement also allows one man to carry the instrument proper and the other, the tripod and leveling head, thus distributing the carrying weight. Where the work necessitates frequent setting up, or where the working space is limited, as in shafts, etc., this feature is invaluable.

**Erecting Eye-piece.** There are two points in the field instrument used in Europe to which the American engineer cannot become habituated—three leveling screws instead of four and an inverting eye-piece. We would say that even the European engineers, after using the American instrument, lose their love for these points.

Besides the great advantage of the erecting eye-piece in viewing the image erect, the modern achromatic lens combination gives a field of view and strength of light equal to the inverting eye-piece for all practical purposes. The advantages of an inverting eye-piece are more theoretical than practical.

The H. & B. stock transit has an erecting eye-piece. The inverted is furnished when specially ordered at no additional cost.

**Accessibility of the Compass Needles.** The compass needle is convenient and quick of access for inspection and balancing. The ring with affixed glass pries off its base by gently pressing upward. No springs, wax or split rings to bother the engineer, who neither

has the tools nor experience for such work, which generally comes under the province of an instrument manufacturer.

**Verniers Directly in Line of Sight.** Horizontal verniers are placed under the telescope, directly along the line of sight. The extra large openings allow the maximum of light. Their glass covers (French plate) are raised, making them easy to keep clean from accumulations of dust and moisture, so hard to remove from the old sunken well type.

The verniers, for reading the horizontal limb, are placed directly under the telescope, or at the north and south points of the vernier plate, so that after sighting through the telescope, the engineer can read the vernier under the eye-end of the telescope without changing his position.

The verniers for reading the horizontal limb are usually placed between the standards (or at right angles to the telescope, *i. e.*, east and west) or at the southeast and northwest points, between the standards and the south and north points of the plate respectively.

In the first case (where the verniers are between the standards) the engineer, in order to read the vernier, must walk around the tripod to one side or the other and in doing so he is liable to shake the instrument.

In the second case (where the verniers are placed at the 45° points) the observer must either change his position, or else he must read the vernier obliquely, with risk of error through parallax. In reading, the observer's eye should be placed precisely over the graduations, and if the magnifier is used, this must be held parallel with them, for if not so held, parallax or apparent shifting of the graduations from their true place will be the result.

**Rigidity.** Being of rigid construction, adjustments are retained under adverse conditions and rough handling, such as construction and location work. The weight of the composing parts is reduced to the minimum without sacrificing rigidity, without which no engineering instrument is practical.

**Aluminum as a Material for Surveying Instrument Parts.** We have given this subject a great deal of thought for the last fifteen years, but up to date no alloy of aluminum has been made that will replace bronze metal for the manufacture of "precision instruments." We have experimented with at least one hundred different alloys, but so far with no success. Aluminum in its pure state cannot be used at all. It is as soft as lead, and no condensing under the hammer will harden it sufficiently for use. In the pure state it is tougher than copper and can neither be turned, filed, drilled, tapped nor finished properly. Its coefficient of expansion and contraction is such that a transit or level would not keep its adjustment three days in succession in our varying climate. At every change of temperature, of say ten degrees, the entire instru-

ment would have to be readjusted. You can see from the above that there are "lions in the way" against its use, for, as Professor Hilgard, of the United States Coast Survey, said in speaking of aluminum as a material for surveying instruments, "It will not do to sacrifice accuracy for portability."

**Stock Features.**

**Graduations on Solid Silver.** The graduations of the horizontal and vertical circle are upon inlaid sterling silver, which do not corrode and discolor when exposed to gaseous atmosphere, as do those on brass.

**Dust Guards.** The leveling screws, the three tangent screws and the telescope objective slide are all protected by complete sets of dust and rain guards

**Improved Quick Cross-Wire Focus.** Five thread movement gives immediate and precise focus to cross wires. All parts are inside. No gumming, sticking or lost motion. Eye end cannot be knocked or jarred out of position.

**Special Finish.** Standards, telescope, plates, etc., are hand polished and heavily lacquered. This finish is a beautiful dark bronze color, which prevents temporary blinding by reflected light rays common to the natural bright color.

**Right Angle Sighting Slits.** All transits with vertical arcs have opposite sighting slits, similar to those on a surveyor's compass, which are used as follows. When the 0° of the vernier cuts 0° on the vertical arc (or circle) and the index on the opposite clamp is made to cut a line that will be found on middle brace of standard, a right angle sight is obtained through these slits. This arrangement is used for offsetting right angles, etc., without changing the set-up of the horizontal verniers.

**German Silver Tangent Screws.** All (3) tangent screws are of German silver, individually fitted and of fine movement, having 48 threads to the inch.

**Quality of Composing Parts.** All metal is hard, red brass. On the instrument or tripod there is not a single part of cheap, soft, pressed yellow brass.

**Serviceability.** Each of the above refinements peculiar to H. & B. instruments means additional manufacturing cost, but increases their accuracy, desirability and length of service.

**The Parts of a  
Heller & Brightly Instrument**

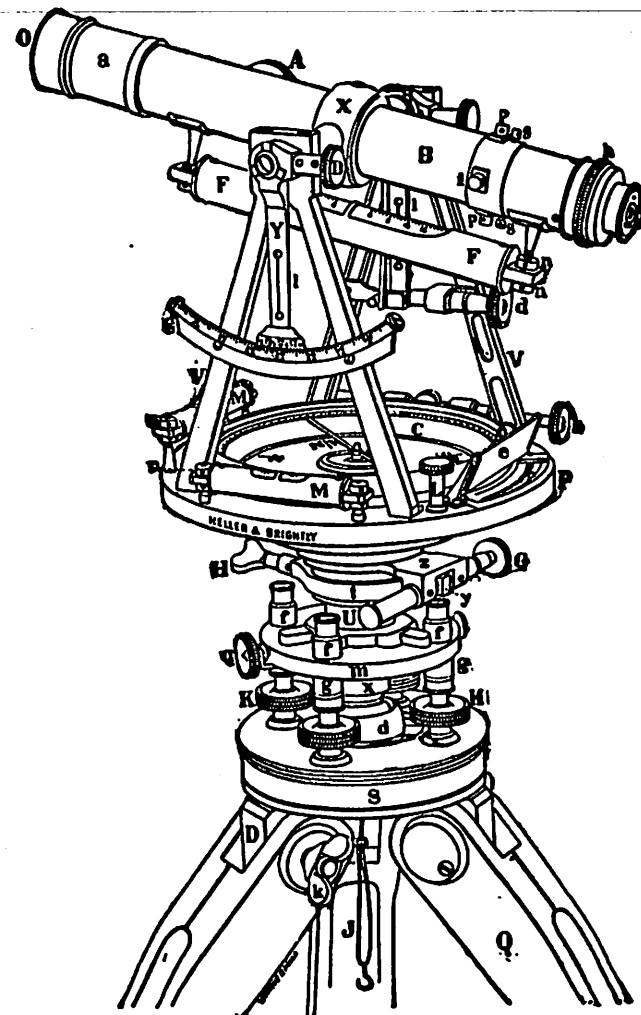

Refer to descriptions on the following pages.

## DESCRIPTION OF INSTRUMENTS.

## TRANSIT.

(See Illustration for explanatory letters.)

*a.*—Dust and rain-guard to object-slide of telescope.

The object-slides of all telescopes are necessarily exposed to flying dust, grit, etc.; this settles on the slide and is carried into the main tube of the telescope, rapidly wearing the tube and the slide, destroying both the accurate projection of the object-glass in a straight line and the truth of the line of collimation. Dampness and rain were also admitted inside the telescope, dimming the glasses and settling on the cross-wires. This arrangement *a* is a perfect safeguard against all these evils. The parts *f* and *g* are also dust-guards to the leveling-screws *K*.

*b.*—The vernier-plate tangent-screw. This tangent-screw has also a dust and rain-guard. This has a German silver spiral opposing spring.

(Both the tangent-screw *b* and the one moving the axis of the telescope (seen just below *n*) are provided with an arrangement for taking up "lost motion," or wear in the screw. See pamphlet, page 65, Report of Comm. of Civ. Eng.)

*c.*—Ivory reflectors over the glass windows of the two verniers *p*. (The second vernier *p* and its ivory reflector *c* are on the opposite side of the horizontal plate *P*.)

(All engineers must have noticed the difficulty of reading the verniers *p* on a bright day, this difficulty being caused by the glare of the silver surface, which renders necessary the shading of the verniers by the hand or a hat. The ivory reflectors *c* remove this annoying glare; they are also inclined at such an angle as to throw a soft white light on the divisions. In mine surveying or night observations light from a lamp or lantern falling on these reflectors allows the divisions of the horizontal plate and its verniers to be easily seen and read.)

*f.*—Dust-caps for protecting upper parts of leveling-screws *K* from dust, rain, etc.

*g.*—Stuffing-boxes for protecting lower parts of leveling-screws *K* from dust, rain, etc.

*k.*—The lower end of these leveling-screws *K* are so made as to be perfect balls, which work and are concealed in a socket *k*.

By this means, while using the leveling-screws *K*, a smooth, equable motion is had without indenting the lower parallel plate *S*, on which they rest, and also facilitating the use of the "plummet shifting plate" *d*.

*d.*—Shifting plate to tripod head, for precisely setting the plummet of the transit over a point on the ground after approximately setting the plummet by means of the tripod legs, the plummet being suspended from the centre of the instrument at *J*.

*Q.*—New form of tripod leg, in which the wooden leg *Q* incloses the brass cheeks of the tripod head, the leg being tightened or loosened by merely turning the threaded wing-nut *K*. A screw on the end of the through bolt prevents the wing-nut being screwed too far out and lost.

**NOTE.**—In the old form of tripod leg, in which the wood is inclosed by the brass cheeks of the tripod head, trouble constantly arose, pieces of paper or leather being resorted to to take up the shake occasioned by the wood of the legs contracting in dry weather or by wear, and in damp weather the swelling of the wood also creating difficulty. In the above new form of tripod leg all these annoyances are overcome.

It will be noticed that there is a "sighting slit," similar to those in the sights of a Surveyor's Compass, in the vernier clamp of the vertical arc; there is also a similar "sighting slit" in the opposite clamp *I*. (This slit, however, can be only partially seen in the cut.) The use of this is as follows: When the *o* (or zero) of the vernier clamp cuts  $30^\circ$  on the vertical arc and the index on the opposite clamp made to cut a line that will be found on the brace of the standard *V*, a right-angled sight is had through the sighting slits. This is convenient for offsetting, right angles, etc.

*h.*—By turning the milled head *h* the eye-piece is brought to focus the cross-wires at *p*.

The graduated vertical arc *g* has two rows of figures—one for angles of elevation, the other for depression. The telescope can be set perfectly level by means of the long-level bubble *F F* and the tangent-screw (*d*) on the standard of the telescope. If an angle of depression is required to be read, the vernier arm is made to touch the screw at the left-hand end of the vertical arc *g*; the zero lines (or  $0^\circ$ ) of the vertical arc and the vernier arm will then agree. Then clamp the vernier arm to the axis of the telescope by means of its milled-head screw *D*. On depressing the telescope the vernier arm will show the angle passed over. If, after reaching the end of the arc, a greater angle than  $60^\circ$  be required, proceed as follows: Clamp the axis of the telescope by means of the clamp *R*; unclamp the vernier clamp and move it back until it again touches the screw *R*; loosen the clamp and again move the telescope. By thus repeating the angle the entire circle can be read. It will be observed that by merely unclamping the vernier clamp and the clamp *R* from the axis of the telescope the telescope can be revolved in any direction, as if it were merely a "plain" Transit.

**B.**—A ring surrounding the telescope, and carrying four capstan-headed screws, two of them, *p p*, being at top and bottom, while the other two are at the side and at right angles to *pp*; these capstan-headed screws are to be used in adjusting the cross-wires of the telescope to the "line of collimation." The small holes around the heads of *p p* admit the end of a small steel pin or lever to turn them in case adjustment is necessary. Besides these four capstan-headed screws, there are at the top and bottom of the telescope two other capstan-headed screws *SS*; these latter are for adjusting the two slides carrying the stadia wires. It may be as well to state that, as the slides to which these wires are

attached are moved independently of the diaphragm carrying the ordinary horizontal and vertical cross-wires, the stadia wires can be at any time adjusted without fear of disturbing in the least any of the adjustments of the ordinary cross-wires.

*n.*—Capstan-headed nuts for adjusting the long-level bubble tube D. One end of this tube can be raised or lowered by means of these nuts *n n*, one of which must be loosened before the other is tightened.

*E. O.*—Telescope.—*X.*—Axis of telescope. One end of the axis is arranged with an adjustable block moved by a screw; this is for the adjustment of the cross-wires to the tracing of a vertical line.—*F.*—Brass tube inclosing a sensitive glass level bubble.—*L.*—Screw for raising or lowering compass needle.—*C.*—Compass box.—*R.*—Clamp for holding telescope in any required position.—*p.*—Vernier for reading horizontal limb or circle. This vernier is covered with a glass window. There is a second vernier opposite to this, but it is not shown.—Clamp screw for binding the two plates together. After such binding the upper or vernier plate can be moved very slowly by means of the tangent screw *b.*—*y.*—Clamp to lower socket.—*H.*—Clamp screw to clamp *y.*—*G.*—Tangent screw, or set screw to move *y.*—*S.*—Large screw cap to secure instrument to tripod.—*r.*—Capstan-headed screws for raising or lowering the two levels *M* in adjusting. The curved piece seen projecting over the level *M* at the front of the compass plate is intended as a guard to protect the glass level bubble in *M* from accident.

Improvements to Transit.

*P.*—The verniers, *P*, for reading the horizontal limb, are placed directly under the telescope, or at the North and South points of the vernier plate, so that after sighting through the telescope at *E*, the engineer can read the vernier under the eye end of the telescope without changing his position from that end.

The verniers for reading the horizontal limb are usually placed either between the standards (or at right angles to the telescope, *i. e.*, East and West) or at the Southeast and Northwest points, between the standards and the South and North points of the plate respectively.

In the first case (where the verniers are between the standards) the engineer, in order to read either vernier, must walk around the tripod to one side or the other, in doing which he is liable to shake the instrument.

In the second case (where the verniers are placed at the 45° points) the observer must either change his position, as before, or else he must read the vernier obliquely, with risk of error through parallax. For in reading verniers the observer's eye should be placed precisely over the graduations, and if the magnifier is used, this must be held parallel with them, for if not so held parallax, or apparent shifting of the graduations from their true place, will be the result.

*L.*—New forms of clamps to horizontal limb, *O*, and vernier plate *P*; these can be clamped and released without disturbing the levels or the sighting of the telescope.

*G.*—Instead of the two opposing tangent screws below the horizontal limb, *O*, we have substituted one tangent screw with German silver opposing spring.

While the magnifying power of the telescope remains unaltered and time can be read as heretofore on an ordinary watch dial at 983 feet distance, we have improved the telescope by enlarging "field of view" and increasing the illumination, thus enabling the surveyor to begin work earlier and continue it later in the day.

For explanation of other parts of the telescope, tripod and instrument, see explanatory remarks under head of Leveling Instrument.

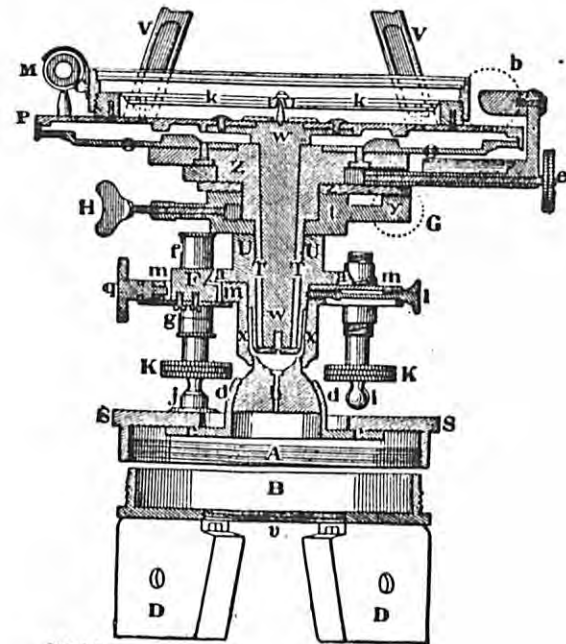

HELLER & BRIGHTLY'S IMPROVED TRANSIT  
Section showing Long Compound Centres, Horizontal Limb, Vernier Plate Clamps, Etc.

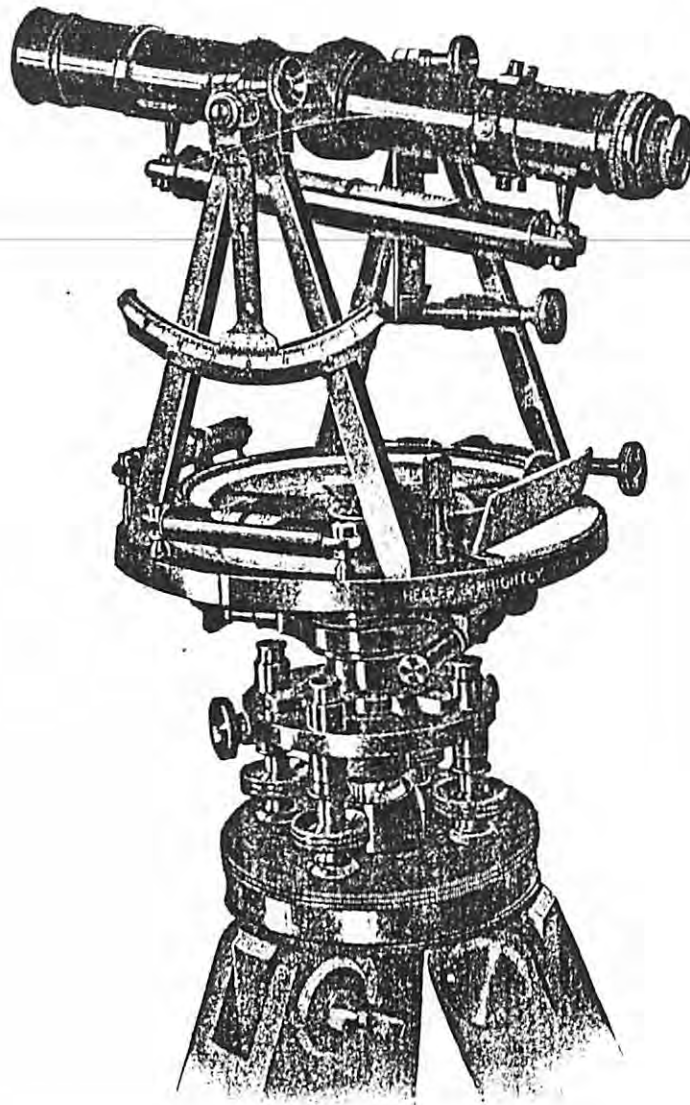

No. 1B—Large

**COMPLETE COMBINED TRANSIT AND LEVELING INSTRUMENT**

Beautiful dark bronze finish to all parts (heavily lacquered). Infinite care used in perfecting H. & B. design and accuracy.

60° Vertical Arc.....\$217.00

**HELLER & BRIGHTLY LARGE COMPLETE COMBINED TRANSIT AND LEVELING INSTRUMENT.**

This instrument is designed for general surveying. It is well adapted for railroad and bridge construction and extensively used by county surveyors, highway engineers, etc. Every attachment is furnished with the instrument to expedite quick and accurate field work.

The long sensitive graduated telescope level gives satisfactory results for general leveling, allowing one instrument to be used for both purposes. Where there is occasional leveling work, this instrument fully meets such requirements. Where there is much leveling work to be done, the Wye-Level should be used.

The telescope has the best obtainable definition, with flat field and an abundance of light, magnifying from twenty-eight to thirty diameters and being well adapted for quick and accurate stadia measurements.

The regular graduation to horizontal plate reads to single minutes, but the extra large diameter of this circle (7" outside diameter, 6½" at reading edge) permits a 30" or 20" reading that is easily discernible, without straining the eyes. This feature will be found very essential where there is much triangulation to be done.

**Specifications for Large Transits No. 1 to No. 1D.**

Telescope 12 inches, erecting eye-piece; 1¼ inch objective, magnifying from 28 to 30 diameters. Telescope balanced in its axis, reversing at both eye and object ends, with one end of its axis adjustable. Eye-piece has an improved threaded sleeve, for quick focusing cross wires, all covered, dust proof, consequently no gumming or sticking. Slide for closing aperture in eye-cap when not in use. The lense combination gives a full flat field so necessary for satisfactory stadia work. Dust guard to objective slide. Line of collimation correct for all distances. Horizontal circle 6½ inches in diameter at reading edge, being graduated upon inlaid silver and numbered in two rows, inside row from 0° to 360° and outside in quadrants 0° to 90°, figures inclined in the direction of their reading. Every quadrant of horizontal circle is marked with its magnetic bearings, as from 0° N. to 90° E. Every 10 degrees is marked N. E. from 90° E. to 180° S. Every ten degrees is marked S. E., etc. The convenience of this form is, that at starting, the vernier of the horizontal circle be set to read the same bearing as the needle, the needle can then be raised off the center pin and both the angles and magnetic bearings read from the horizontal circle without using the needle for the balance of the survey. This precludes any error from local attraction, or possibility of reading wrong end of needle. It prevents loss of time waiting for the needle to settle. It reduces the actual use of the needle to a minimum, keeping the fine point of the pivot pin (center pin) sharp, which is so essential to a live needle. Double opposite verniers read to single minutes. Extra large openings allow the maximum of light.

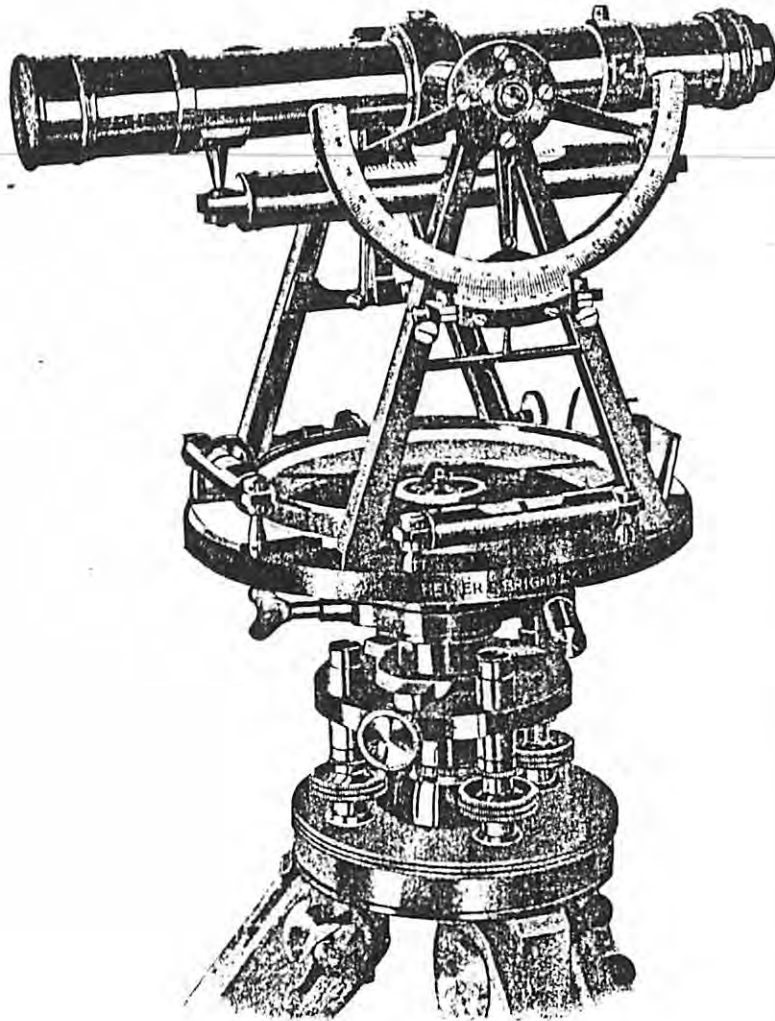

No. 1C—Large

### COMPLETE COMBINED TRANSIT AND LEVELING INSTRUMENT

Note the refinements of the H. & B. Vertical Circle—adjustable, pivoted, flap vernier—solid silver.

5¼" Half Vertical Circle.....\$230.00

Protected by raised, white French plate glass covers which are easy to keep free from dust and moisture. Removable ivory reflector to A vernier.  
Five-inch magnetic needle with ring divided to half degrees and numbered in two rows, inside row in quadrants, the other a continuous one from 0° to 360° for repeating an angle. Any style numbering of compass ring or horizontal plate at no additional cost.

Needle quickly accessible for examination and balancing. White French plate glass cover, dust and waterproof. All level vials ground, graduated and of the proper sensitiveness. All (3) tangent screws of German silver, individually fitted and of fine movement, with opposite compensating spring.

Long compound centers to plates—bronze against bell metal. Shifting center to leveling head for precisely centering over and under a point after approximately setting up with tripod legs. Leveling head detachable from tripod and instrument proper; can be left on tripod or placed in carrying box when not in use. Leveling screws have dust and rain guards, also a spun cup over bottom to prevent marring of tripod cap, when leveling screws are clamped. Tripod legs of straight grained ash, full length, rigid, aluminum alloy head. Weight reduced to a minimum. Round or split legs with tight steels shoes. Wooden protection cap to head to prevent injury to threads from falls or knocks.

Telescope, plates, standards, etc., polished, finished a dark bronze color, heavily lacquered.

All metal parts of hard, red, cast brass, carefully fitted. On the whole outfit including the tripod there is not a single piece of stamped or pressed, soft, yellow brass. This insures the maximum of service.

Polished carrying case. Inside blocks afford convenient placing and safety in transportation. Leather strap with hand grip, lock, key and hooks. Permanent pneumatic bumpers to bottom of box. Contains accurate steel point plummet, hand magnifier, sunshade, telescope objective cap, adjusting levers, screw drivers, etc.

- Transit No. 1 (plain), as described above, with clamp and tangent to telescope (see note † below).....\$190.00
- Transit No. 1A, as described above for No. 1, but with long 7-inch sensitive level, clamp and tangent to telescope.....\$210.00
- \*Transit No. 1B, as described for No. 1, but with level, clamp and tangent to telescope. Right angle sighting slits and 60 degree vertical arc (graduated upon silver, 3¾ inches radius) as illustrated by cut on page 74 .....\$217.00
- †Transit No. 1C, as described for No. 1, but with level, clamp and tangent to telescope, right angle sighting slits. Has half (180 degree) vertical circle 5¼ inches in diameter. Graduations upon silver, with adjustable flap double vernier (solid piece of silver) reading to single minutes, as illustrated by cut on page 76.....\$230.00
- †Transit No. 1D, as described for No. 1, but with level clamp and tangent to telescope, right angle sighting slits. Has a full (360 degree) vertical circle 5¼ inches in diameter. Graduations upon silver, with adjustable flap double vernier (solid piece of silver) reading to single minutes .....\$235.00

For additional price of magnetic variation plate, fixed or adjustable stadia, Solar attachment, cross wire reflector, extension tripod, etc., see page 85.

\* See note page 79.

† See note page 79.

#### † Telescope Clamp and Tangent Screw.

As it has been found almost impossible to direct the cross wires of the telescope of plain transits precisely on the object by hand alone, we now place upon all our Plain Transits, without any additional charge a clamp and tangent screw for the purpose of such directing.



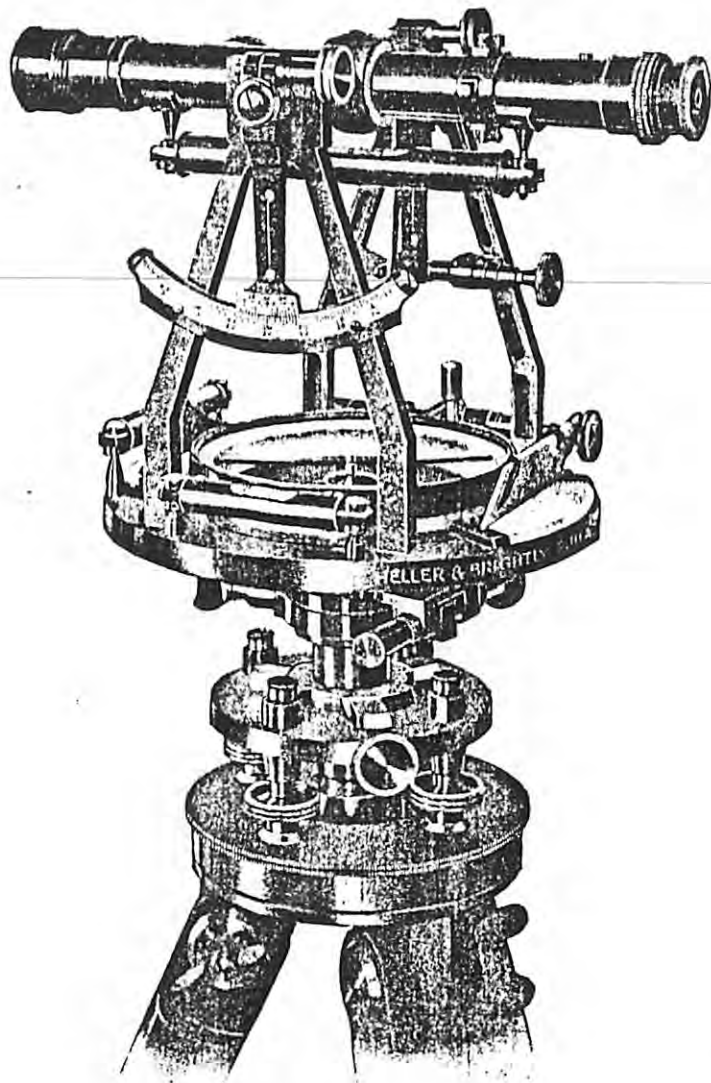

No. 2B—Intermediate

**COMPLETE COMBINED TRANSIT AND LEVELING INSTRUMENT**

Accurate and rigid construction throughout, exemplifying the utility of a light complete instrument.

60° Vertical Arc.....\$200.00

Weight—Plain Transit No. 1 with clamp and tangent to telescope.....	15 lbs.
"          No. 1 A with level to telescope, clamp and tangent .....	15½ lbs.
Complete Transit No. 1 B. or C. (with half or full vertical circle) .....	16¼ lbs.
Ready for use with straight leg tripod.....	23 lbs.
Ready for use with expansion tripod.....	26 lbs.
Instrument and straight leg tripod packed ready for shipment (two boxes) about.....	71 lbs.
Instrument and extension tripod packed ready for shipment (two boxes) about.....	75 lbs.

Dimensions of polished carrying case proper, 14 inches long, 10 inches wide, 15 inches high.

Dimensions of transit outside shipping box, 16 inches long, 11 inches wide, 16 inches high.

Dimensions of tripod (straight leg) shipping box, 58 inches long, 6 inches wide, 6 inches high.

Dimensions of tripod (extension) shipping box, 41 inches long, 6 inches wide, 6 inches high.

**\* Vertical Arc.**

Philadelphia arc placed on No. 1B, No. 2B, and No. 3B transits, is well adapted for ordinary surveying practice, where the depression and elevation does not exceed 60 degrees.

Owing to its compactness and small exposure beyond the standards, possibility of injury due to side or end knocks is reduced to a minimum.

Swinging double vernier reading to single minutes, clamp to telescope axle. Arc numbered in two rows, 0° to 60° from each end. Check screws to end of arc limit the swing of vernier arm.

**† Vertical Circle.**

Half and full vertical circles as placed on No. 1C, No. 1D, No. 2C, No. 2D, No. 3C and No. 3D transits have many exclusive features incorporated in them. (1) Flap vernier (solid piece of silver). (2) Vernier is adjustable so that zero can be quickly shifted either way and then clamped tight. (3) Vernier is pivoted and can be swung out from circle proper, when not in use. This greatly adds to the life of the divisions, thereby overcoming the disadvantage of the usual fixed bottom type. (4) Vernier is close reading with set-screw in back to regulate inward movement. When set, it does not touch face of circle. (5) All graduations upon sterling silver.

**Specifications for H. & B. Intermediate Transit No. 2.**

This instrument fills the need, where the No. 1 size is too heavy and size No. 3 too light. It is adapted for railroad, land surveying and open or underground mine work, etc., where a portable instrument with a direct reading, graduated to single minutes is preferred.

Diameter of horizontal plate will satisfactorily allow a 30 second, direct reading graduation, but the regular division of a single minute is most used, being the easier read. The spaces between the graduations are larger—relatively proportional to the diameter of the horizontal limb.

Close stadia work can be done, owing to the unusual high power and long focal length obtained by using an improved lens formula which allows the maximum of light, magnifying power and a flat field.

This transit has every feature as specified on page 75 for size No. 1, being identically similar except as to size and weight.

Telescope 9 inches long, erecting eye-piece, 1.5-1.6 inch objective, magnifying power of 25 diameters. Dust guard to telescope objective slide. Clamp and tangent to telescope.

Horizontal circle 5¼ inches diameter at reading edge, graduated upon in-laid silver with two double opposite verniers reading to single minutes. Vernier

openings are extra large, allowing an abundance of light. Covering of raised white French plate glass, easy to keep free from dust and moisture. Plate level vials graduated and of proper sensitiveness.

Close reading  $3\frac{1}{2}$ -inch compass needle, easy of access, with ring divided to half degrees. Numbering of horizontal circle and compass ring similar to large No. 1 transit (see page 75). Any special style or combination at no additional cost. Telescope, plates and standards polished, dark finish, heavily lacquered. Tangent screws of German silver.

Shifting center to leveling head for a precise set-up under or over a given point. Right angle sighting slits with index for offsets, on transit with vertical arc or circle.

Tripod, round or split legs of straight grained ash, full length, rigid; steel shoes, head of aluminum alloy. Wooden protection cap to head, prevents injury to threads from falls or knocks.

All metal parts of hard, red cast brass, carefully fitted. On the whole outfit including the tripod, there is not a single piece of stamped or pressed, soft, yellow brass. This insures the maximum of service.

Polished carrying case. Inside blocks afford convenient placing and safety in transportation. Leather strap with hand grip, lock, key and hooks. Permanent pneumatic bumpers to bottom of box. Contains accurate steel point plummet, hand magnifier, sunshade, telescope, objective cap, adjusting levers, screw drivers, etc.

Plain Transit No. 2, as described above, with clamp and tangent to telescope (see note † below).....	\$175.00
Transit No. 2A, as described above for No. 2, but with 5-inch sensitive level, clamp and tangent to telescope.....	\$193.00
*Transit No. 2B, as described for No. 2, but with level, clamp and tangent to telescope. Right angle sighting slits and 60 degree vertical arc (graduated upon silver, $2\frac{1}{2}$ inches radius) as illustrated by cut on page 78 .....	\$200.00
†Transit No. 2C, as described for No. 2, but with level, clamp and tangent to telescope, right angle sighting slits. Has <i>half</i> (180 degree) vertical circle $4\frac{1}{2}$ inches in diameter. Graduations upon silver, with adjustable flap double vernier (solid piece of silver) reading to single minutes, as illustrated by cut on page 81.....	\$213.00
†Transit No. 2D, as described for No. 2, but with level, clamp and tangent to telescope, right angle sighting slits. Has a <i>full</i> (360 degree) vertical circle $4\frac{1}{2}$ inches in diameter. Graduations upon silver, with adjustable flap double vernier (solid piece of silver) reading to single minutes....	\$218.00

For additional price of magnetic variation plate, fixed or adjustable stadia, Solar attachment, cross wire reflector, extension tripod, etc., see page 85.

\* See note page 79.

† See note page 79.

#### † Telescope Clamp and Tangent Screw.

As it has been found almost impossible to direct the cross wires of the telescope of plain transits precisely on the object by hand alone, we now place upon all our Plain Transits, without any additional charge, a clamp and tangent screw, for the purpose of such directing.

Weight—Instrument proper .....	7 lbs.
Leveling head (detachable).....	2 lbs.
Tripod—straight legs .....	6 lbs.
Ready for use with straight-leg tripod .....	15 lbs.
Ready for use with extension tripod.....	17 lbs.
Instrument and straight-leg tripod packed ready for shipment (two boxes) about.....	63 lbs.
Instrument and extension tripod packed ready for shipment (two boxes) about.....	68 lbs.

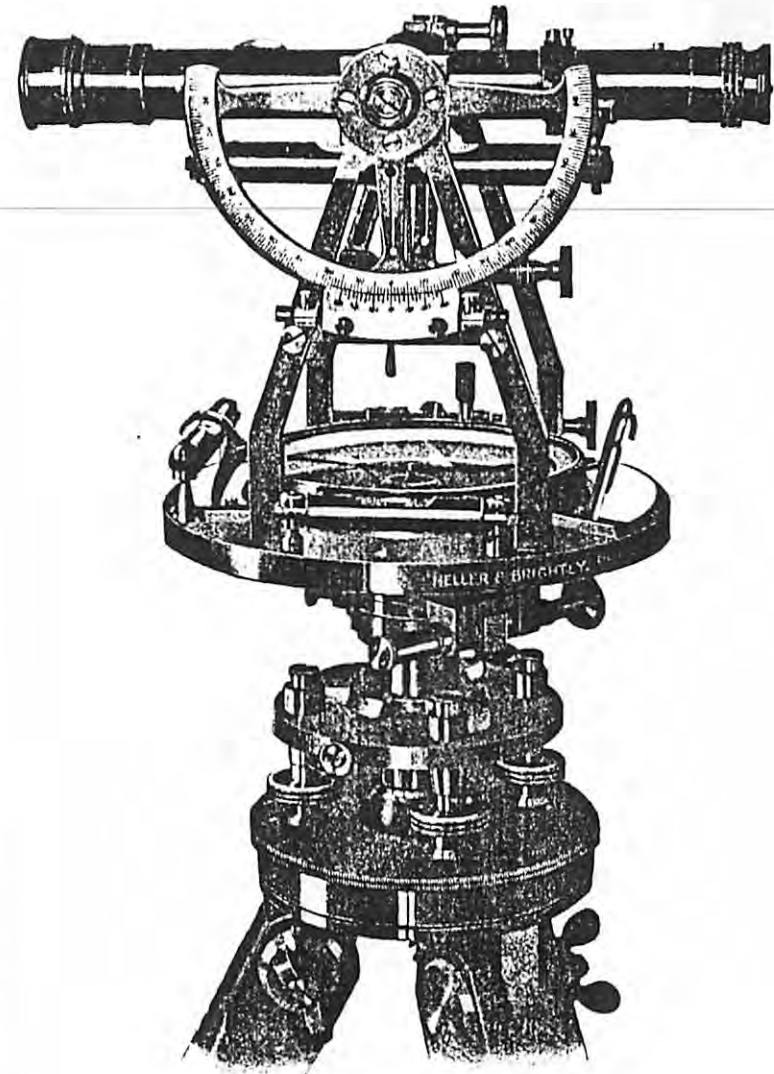

No. 2C—Intermediate

### COMPLETE COMBINED TRANSIT AND LEVELING INSTRUMENT

All H. & B.'s, Large and Small, have complete sets of dust and rain guards to all threads. Every constructional detail is given utmost consideration.

$4\frac{1}{2}$ " Horizontal Vertical Circle.....\$213.00

Dimensions of polished carrying case proper, 11 inches long, 8 inches wide, 12 inches high.

Dimensions of transit outside shipping box, 12 inches long, 9 inches wide, 13 inches high.

Dimensions of tripod (straight leg) shipping box, 57 inches long, 5 inches wide, 5 inches high.

Dimensions of tripod (extension leg) shipping box, 41 inches long, 5 inches wide, 5 inches high.

**Specifications of Small Mining and Reconnaissance Transit.**

This instrument we believe is the smallest practical complete light weight transit obtainable to-day. Every part has been reduced and ribbed in order to obtain the minimum practical weight to avoid sacrificing its rigidity, without which no engineering instrument is satisfactory.

Where portability is the prime consideration and diameter of graduated horizontal circle and power of telescope of lesser importance, this instrument is specially adapted for such conditions.

It is compact and has a telescope that although short is very powerful, magnifying 23 diameters. The eye-piece, designed for stadia work, has a flat field and allows the maximum of light. In other words, this is a complete transit in the fullest sense. Years of service have proven that it will stand up under rough conditions incidental to locating and reconnaissance work. This instrument is similar in outline and general construction to No. 1 and No. 2 transits, having their every feature and being identical except as to size and weight.

Telescope 7¼ inches, erecting eye-piece; 15-16 inch objective, magnifying power of 23 diameters. Dust guard to telescope objective slide; 4½-inch telescope level bubble, graduated and of proper sensitiveness, with clamp and tangent to telescope. Sixty degree vertical arc, 2¼ inches radius, with double vernier reading to single minutes. Graduations upon solid silver.

Horizontal circle, 4½ inches in diameter at reading edge, graduated upon inlaid silver with two double opposite verniers reading to single minutes. Extra large vernier openings allow the maximum of light. Protected by raised, white French plate glass covers, easy to keep free from dust and moisture.

Close reading 3-inch compass needle, easy of access, with ring divided to half degrees. Numbering of horizontal circle and compass ring similar to large No. 1 transit. (See page 75.) Any special style or combination at no additional cost.

Telescope, plates and standards polished, dark finish, heavily lacquered. Tangent screws of German silver.

Plate level vials graduated and of proper sensitiveness.

Shifting center to leveling head for precise set up, under or over a given point.

Right angle sighting slits with index for offsets, on transit with vertical arc or circle.

Tripod, round or split legs of straight grained ash, full length, rigid steel shoes, head of aluminum alloy. Wooden protection cap to head prevents injury to threads from falls or knocks.

All metal parts of hard, red, cast brass, carefully fitted. On the whole outfit including the tripod, there is not a single piece of stamped or pressed, soft, yellow brass. This insures the maximum of service.

Polished carrying case. Inside blocks afford convenient placing and safety in transportation. Leather strap with hand grip, lock, key and hooks. Permanent pneumatic bumpers to bottom of box. Contains accurate steel point plummet, hand magnifier, sunshade, telescope objective cap, adjusting levers, screw drivers, etc.

\*Transit No. 3B, as described above and as illustrated by cut on page 84. \$195.00

†Transit No. 3C, as described for No. 3B, but with half (180 degree) vertical circle 4½ inches in diameter. Graduations upon silver, with adjustable flap double vernier (solid piece of silver) reading to single minutes .....\$208.00

‡Transit No. 3D, as described for No. 3B, but with full (360 degree) vertical circle 4½ inches in diameter. Graduations upon silver, with adjustable flap double vernier (solid piece of silver) reading to single minutes .....\$213.00

For additional price of magnetic variation plate, fixed or adjustable stadia, Solar attachment, cross wire reflector, extension tripod, etc., see page 85.

\* See note page 79.

† See note page 79.

Weight—Instrument proper .....	5½ lbs.
Leveling head (detachable).....	1¼ lbs.
Tripod—straight leg .....	5¼ lbs.
Ready for use with straight-leg tripod.....	12 lbs.
Ready for use with extension tripod.....	14 lbs.
Instrument and straight-leg tripod packed ready for shipment (two boxes) about.....	61 lbs.
Instrument and extension tripod packed ready for shipment (two boxes) about.....	63 lbs.

Dimensions of polished carrying case proper, 10 inches long, 6¾ inches wide, 11½ inches high.

Dimensions of transit outside shipping box, 12½ inches long, 8½ inches wide, 12½ inches high.

Dimensions of tripod (straight leg) shipping box, 57 inches long, 4 inches wide, 4 inches high.

Dimensions of tripod (extension leg) shipping box, 41 inches long, 4 inches wide, 4 inches high.

**Tunnel Transit.**

Tunnel Transit, with Telescope 17 inches in length—long compound centers, 5-inch magnetic needle, double opposite verniers to horizontal limb (see pages 11 and 35), Franklin Institute Report. Price, including tripod .....\$298.00

**Solar Transit.**

Solar Transit.—This is our regular "Complete Combined Transit and Leveling Instrument," with the addition of the Saegmuller Patent Solar Attachment, which is detachable and can be placed away in the transit box when not in use. See page 25. Price, including tripod.....\$275.00

**Sunflower.**

Heller & Brightly's "Sunflower," for cross-sectioning in tunnels and for testing masonry, with two measuring rods—one eight feet and one fourteen feet long—rods divided into feet and tenths of a foot (other size rods can be furnished), with quick-leveling tripod and extension legs to tripod (see pages 52 to 61); packed in box with all accessories, ready for use..... \$95.00

**Plane Table.**

Plane Table of the most approved modern construction with Alidade—detached Compass Box, level, scale, etc.—Table 24 inches square—alidade with movable edge (this is a most important and time-saving improvement, as double the amount of field work can be done in the same time as with the ordinary style of instrument, and with greater accuracy). Telescope, extra powerful, with vertical arc, and with adjustable Stadia

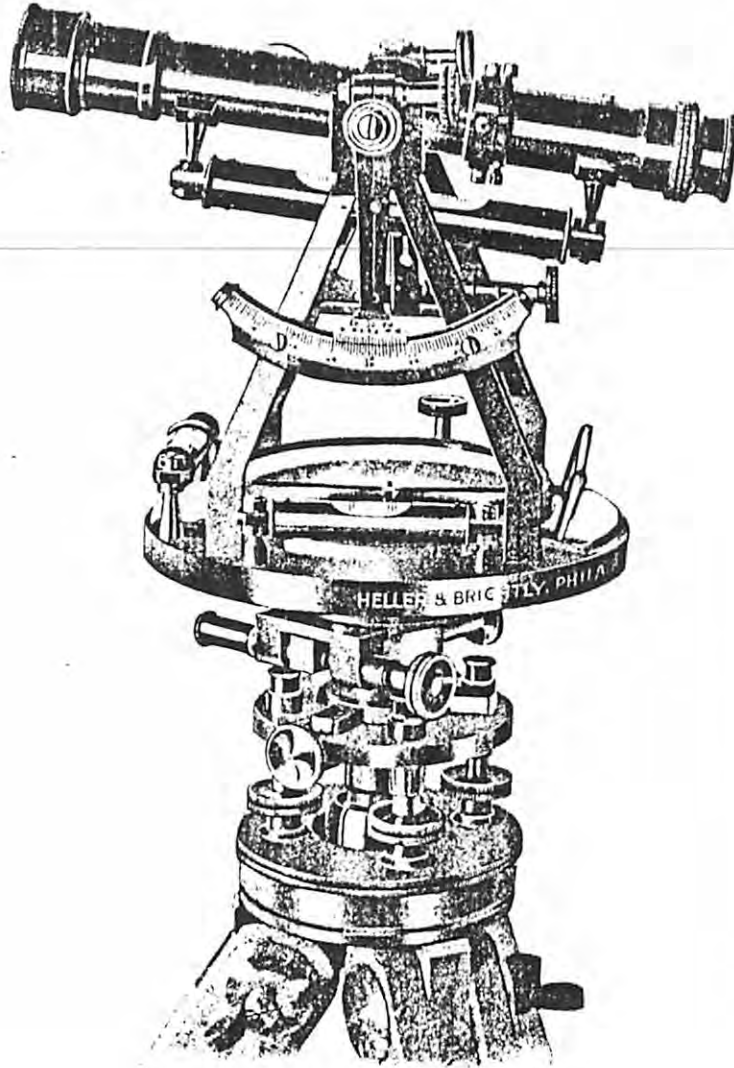

No. 3B—Small

**COMPLETE MINING AND RECONNOISSANCE TRANSIT**

Where can you find the accuracy, stability, quality and completeness of this Small H. & B. Mining and Reconnoissance Transit? Weight, 12½ lbs.

60° Vertical Arc.....\$195.00

hairs. Tripod very firm and with shifting head. The whole instrument braced in a manner to best resist side torsion.....\$295.00  
(Long Level under Telescope, \$10.00 extra.)  
Telemeter Rod (hinged and graduated) to use with Plane Table..... \$25.00

All the above instruments (as well as those that follow) are reduced to about half the weight of instruments made in the ordinary way. This being effected by "ribbing" and "bracing" all the parts.

The mode is fully explained in "The Report of the Committee of Civil Engineers appointed by the Franklin Institute of Philadelphia to examine Heller & Briggley's Improved Transit," and in the paper read before the "American Philosophical Society," page 30.

**Extras to Complete Large, Intermediate or Small Transit and Leveling Instruments.**

(Any or all of which may be added at will.)

20-second or 30-second reading to half or full vertical circle.....	\$5.00
Aluminum guard to full vertical circle.....	5.00
Extension (3), instead of straight legs (when ordered with new instrument) .....	12.00
Extension legs for set (3).....	14.00
Extension leg singly .....	5.00
Regular tripod legs for set (3).....	7.00
Regular tripod leg singly.....	2.50
Detachable top telescope for vertical sighting in shafts (for description and uses, see pages 45 and 46).....	35.00
Saegmuller Solar attachment, prism eye-piece. Aluminum, latest improved. Detachable separate box, packs away in transit case proper. Only with new transit. See page 25.....	55.00
Removable plate reflector for illuminating cross wires.....	4.00
Extra tripod complete with head and three extension legs.....	20.00
Extra regular tripod with head.....	13.50
Small adjustable table (weighing 16 ounces) to attach to tripod for holding lamp (can be placed in box; see description and uses on pages 11 and 43).....	10.00
Slit sights in telescope to fold down when not in use.....	12.00
Center in axis of telescope for vertical plumbing.....	3.00
Half-minute (30 second) reading to horizontal circle.....	10.00
Twenty-second (20") reading to horizontal circle.....	15.00
Ten-second (10") reading to horizontal circle.....	30.00
Fixed or adjustable stadia wires (see * page 87).....	3.00
Disappearing stadia wires.....	5.00
One trivet for tripod (when ordered with new Transit).....	7.00
One trivet for tripod (when ordered separate).....	9.00
Gradiometer .....	7.00
Prism eye cap for vertical sighting in shafts.....	9.50
Draper shifting head.....	7.00
Extra plate for magnetic variations (when ordered with new transit)....	9.00
Reversion level, for leveling with telescope reversed.....	6.00
Waterproof bag to cover instrument.....	.75
High quality transit oil.....	.50

For extra magnetic needles, center pins, levels, compass dial glasses, magnifiers, adjusting levers, plummets, plummet cord, camel's hair brush and buckskin for glasses of telescope, see extras listed after "General Specification," page 89.

NOTE.—The prices of the above attachments apply to both Large, Intermediate and Small Transits, as labor and cost of material is practically the same.

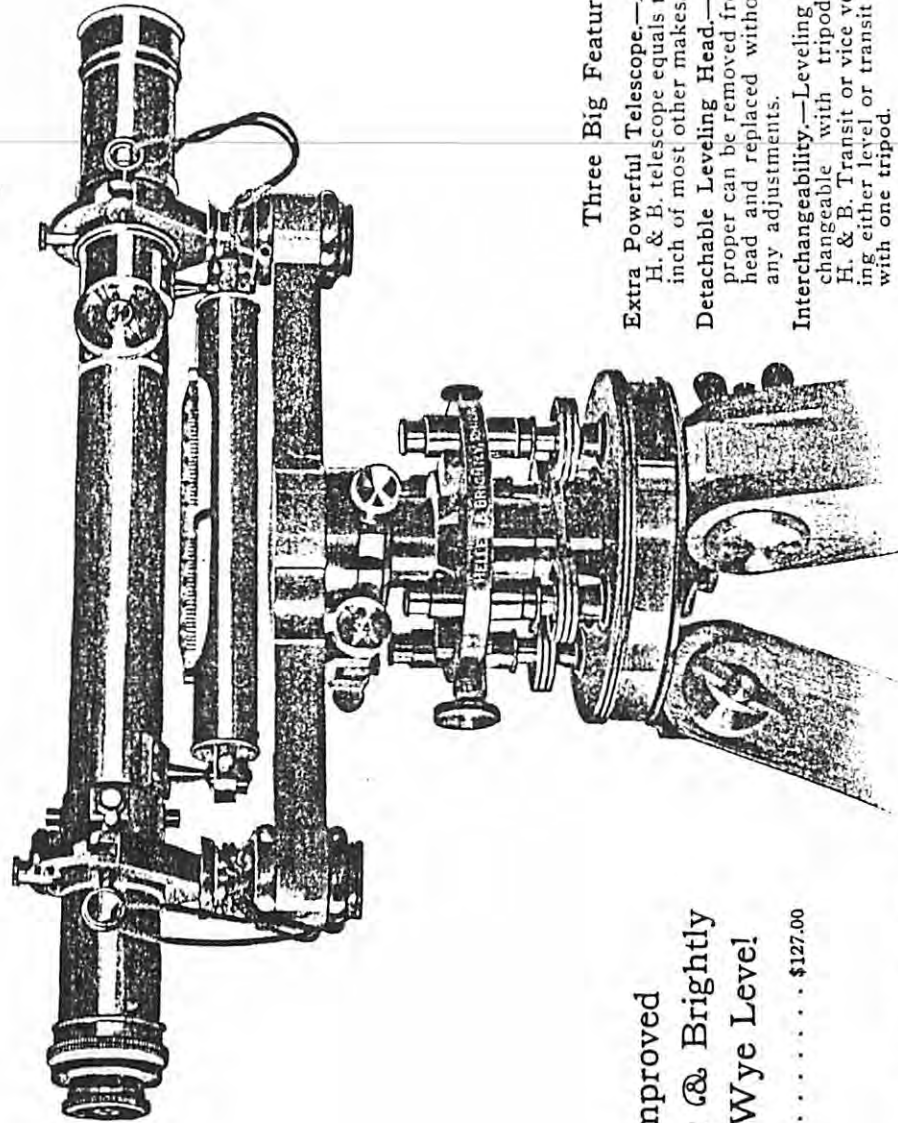

**Three Big Features**

- Extra Powerful Telescope.**—An 18 inch H. & B. telescope equals the 20 or 22 inch of most other makes.
- Detachable Leveling Head.**—Instrument proper can be removed from leveling head and replaced without altering any adjustments.
- Interchangeability.**—Leveling head interchangeable with tripod head of H. & B. Transit or vice versa, allowing either level or transit to be used with one tripod.

**Improved  
Heller & Brightly  
18" Wye Level**

Price . . . . . \$127.00

\* **NOTE**—Many engineers prefer an adjustable to a fixed stadia, as this arrangement entirely eliminates any possibility of confusing stadia with horizontal wire in leveling. A few turns of the small conveniently placed, capstan headed adjusting screws draw stadia wires out of the field of view, without disturbing in the least the adjustments of the regular horizontal and vertical wires. Stadia can be readily reset by bringing wires in to cut one foot of rod at 100 feet.

**Improved H. & B. 18" Wye Level**

Engineers' Leveling Instrument, with "long center" Telescope, bar and centers arranged in such a manner as to detach above the leveling screws, without the possibility of jarring the instrument or its adjustments. Tripod head and leveling screws detachable from the tripod legs, for packing away in box. Telescope 18 inches long, erecting, achromatic and extra powerful. Index lines on Telescope and Y's for setting vertical hair truly vertical. Packed in polished box with sunshade, adjusting pins, etc. For weight and further information, see table page 89. Price, including straight leg tripod.....\$127.00

**Twenty Inch or Twenty-two Inch Telescope.**

The only difference between an 18 inch and a 20 inch or 22 inch Engineers' Level is in the length of telescope, the instrument proper in both cases being the same. The longer telescope increases the magnifying power and is sometimes necessary in a telescope made in the usual manner. We have no call to increase the length of our telescope from 18 inches, for by the use of an achromatic (Steinheil) eye-piece as well as an achromatic object glass, it has as much power as the usual 20 or 22 inch telescope. Any increase of magnifying power, would be a disadvantage, as the impurities and heat undulations of the atmosphere would be magnified and would render the sight wavering. We have made 20 and 22 inch telescopes, but have always been called to change them to the 18 inch. If you should get an 18 inch level from us and still think after use that you would like the telescope 2 or 4 inches longer, we will make a new 20 or 22 inch telescope for you without any extra charge.

**Stadia Wires**

The stadia wires in both the 18 inch and Small Mining Level (described below) are vertical, instead of horizontal as in most other instruments. This precludes any possible confusion with the horizontal leveling wire. To use stadia revolve telescope quarter-turn in Wyes which places the stadia wires horizontal.

Weight—Instrument proper .....	8 lbs.
Leveling head (detachable).....	4 lbs.
Tripod—straight legs .....	63/4 lbs.
Ready for use with straight-leg tripod.....	183/4 lbs.
Ready for use with extension tripod.....	19 lbs.
Instrument and straight-leg tripod packed ready for shipment (two boxes) about.....	53 lbs.
Instrument and extension tripod packed ready for shipment (two boxes) about.....	55 lbs.
Dimensions of polished carrying case proper, 18 inches long, 6 inches wide, 10 1/2 inches high.	
Dimensions of level outside shipping box, 20 inches long, 8 1/2 inches wide, 12 1/4 inches high.	
Dimensions of tripod shipping box (straight leg), 58 inches long, 6 inches wide, 6 inches high.	
Dimensions of tripod shipping box (extension leg), 41 inches long, 6 inches wide, 6 inches high.	

**Small Mining and Reconnaissance Level.**

This Mining and Reconnaissance Level is a companion instrument to the Mining and Reconnaissance Transit, and is a fac-simile of our regular En-

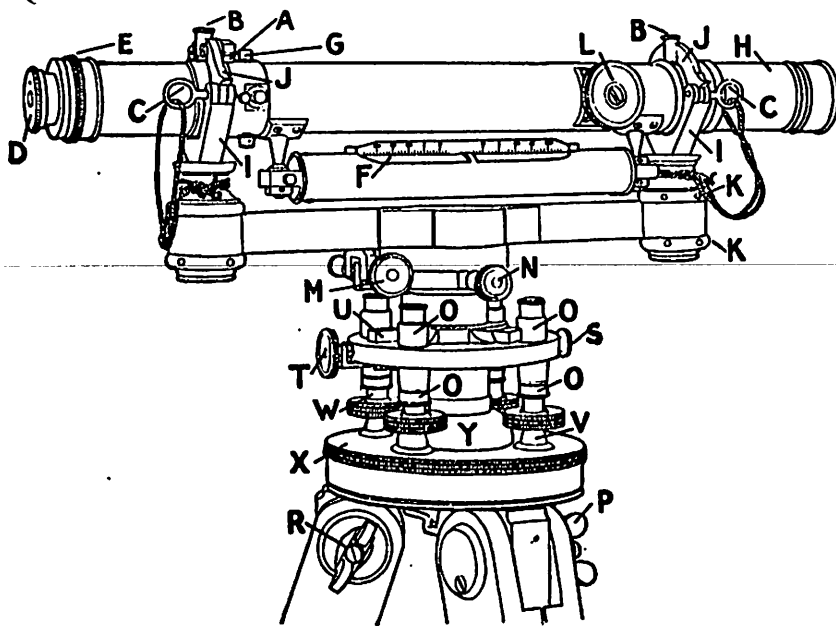

### The Improved Heller & Brightly Level.

One of the reasons for the forty-three years' success of H. & B. instruments is the close study given to the requirements of the careful, accurate engineer.

For instance, the test of years in hard service proves H. & B. Levels strong and rigid, insuring the much desired permanency of adjustments; the additional weight being offset by such features as aluminum tripod head, etc.

Many other advantages offered in the improved design, further guarantee this level.

#### DESCRIPTION

- |   |  |
|---|--|
| <p>A. Stop on telescope sets cross-wire truly vertical when Wyetop is clamped.</p> <p>B. Spiral Springs hold telescope firmly in Wyes.</p> <p>C. Bronze Binding Pins.</p> <p>D. Cap and Shutter to eye piece.</p> <p>E. Eye Piece with quick-thread movement for focusing cross-wires far superior to eccentric, rack and pinion or slide.</p> <p>F. Long Sensitive Ground Level, German silver, graduated scale.</p> <p>G. Cross and Stadia Wires (stadia wires either fixed, adjustable or disappearing).</p> <p>H. Dust and Rain Guard to object slide of telescope, a safeguard against dust evils.</p> <p>I. Supports for telescopes, called Wyes from their shape.</p> <p>J. Wyetops which clamp telescope in Wyes.</p> <p>K. Large Capstan-Headed Nuts for adjusting Wyes.</p> | <p>L. Finger Piece for focusing objective.</p> <p>M. Tangent Screw for horizontal movement.</p> <p>N. Clamp Screw which clamps bar and telescope to center.</p> <p>O. Dust Guards to leveling screws.</p> <p>P. Thumb Nuts which tighten tripod legs.</p> <p>R. Guard Screws to prevent loss of thumb nuts.</p> <p>S. Automatic catch or snap which falls into groove in socket when latter is placed on leveling head. This prevents the possibility of instrument falling off tripod if adjusting screw T is not clamped.</p> <p>T. Screw to adjust movable lug U.</p> <p>U. Lug which clamps socket.</p> <p>V. Cups which form bearings for end of leveling screws. They protect face of lower parallel plate.</p> <p>W. Leveling Screws.</p> <p>X. Lower Parallel Plate.</p> |
|---|--|

#### GENERAL SPECIFICATIONS

Length of Bar: 11 inches.  
 Telescope achromatic, magnifying about 33 diameters. Erecting eye piece, designed to insure flatness of field with plenty of light.  
 Objective: 1 1/4 inch in diameter.  
 Stadia (fixed, adjustable or disappearing) set to read 1 foot of rod at 100 feet unless otherwise specified.

Weight of Level (without tripod): 12 pounds.  
 Weight of Tripod: 6 pounds; rigid, aluminum head.  
 Weight of Level (ready for use): 18 pounds.  
 Packed in polished box, with sunshade and adjusting pins.

engineers' Wye-Level (see description above) in every respect excepting size and weight—length of Telescope 10 3/4 inches—aperture of object glass 1 inch—magnifying power 28 diameters, shows objects erect, and will read face of a leveling rod direct (i. e., without the aid of a target) at 700 feet. This Leveling Instrument fits the tripod head of the Mining Transit, and one tripod, if need be, will answer for both. The whole instrument weighs without tripod 2 1/2 pounds, and is packed in a polished box, 12 inches long, 4 inches wide, and 6 inches deep; a strap is furnished to carry box over the shoulder in the manner of army officer's fieldglass.

Price, without tripod (where small Transit tripod interchanges with Level) . \$100.00  
 Tripod head and legs..... 10.00

#### Extras to H. & B. Wye-Levels.

Fixed or adjustable stadia wires..... \$3.00  
 Short Focus lens..... One \$8.00—pair 15.00  
 Waterproof bag for protecting instrument from dust and rain..... .75  
 Bottle of high grade center oil..... .50  
 Three extension instead of regular, round or split tripod legs (when ordered with a new instrument)..... 12.00  
 Single extension tripod leg..... 5.00

#### Weights of H. & B. Transits and Levels.

	Large Transit	Intermediate Transit	Small Transit	18-inch Wye-Level
Weight of instrument proper	12 1/2 lbs.	7 lbs.	5 1/2 lbs.	8 lbs.
Leveling head (detachable)	3 3/4 "	2 "	1 1/4 "	4 "
Tripod, straight or split legs	6 3/4 "	6 "	5 1/4 "	6 3/4 "
Ready for use.....	23 "	15 "	12 1/2 "	18 3/4 "
Extension tripod.....	10 "	8 1/2 "	7 1/2 "	10 "

#### General Specifications.

	Large Transit	Intermediate Transit	Small Transit	18-inch Wye-Level
Eye piece .....	Erecting	Erecting	Erecting	Erecting
Magnifying power .....	28 diam.	25 diam.	23 diam.	33 diam.
Diameter of objective....	1 1/4 in.	1 1/4 in.	15-16 in.	1 1/4 in.
Length of telescope (reversing) .....	12 in.	9 in.	7 1/4 in.	18 in.
Length of telescope level... ..	7 in.	5 in.	4 1/2 in.	8 in.
Graduations for telescope level on .....	Glass	Glass	Glass	Ger. silver scale
Verniers read to.....	One min.	One min.	One min.	
Length of compass needle..	5 in.	3 1/2 in.	3 in.	
Compass ring divided to... ..	1/2 deg.	1/2 deg.	1/2 deg.	
Diameter of horizontal graduated plate .....	6 1/2 in.	5 1/4 in.	4 1/2 in.	
Diameter of vertical circle..	5 1/2 in.	4 1/2 in.	4 1/2 in.	
Price, complete with light-weight tripod, plumb-bob and usual accessories....	\$217.00	\$203.00	\$195.00	\$127.00

#### New Parts for H. & B. Instruments Liable to Accident or Loss.

The parts of H. & B. Instruments listed below can be satisfactorily supplied without the instrument being forwarded to us. In ordering be sure to furnish the serial number of the instrument found under the letter S on com-

pass dial, consisting of four numerals as—8706. Also size of the instrument as to length of telescope and needle, etc. This is essential for prompt and efficient service. Whenever possible send us the broken part, which will positively identify the piece and size.

All parts in this list are supplied with the understanding that their fit will be as close as possible *without us having the instrument*.

Should a tangent or leveling screw, etc., supplied singly, fit too tight or too loosely an instrument maker should be consulted—if impractical then the local watchmaker or optician. If not available send the leveling head for the leveling screws, frames with nuts for the tangent screws, etc.

Do not ever under any conditions detach any of the main parts from the instrument, as centers, standards, horizontal circle, verniers, etc.

Parts should be forwarded by registered mail to insure delivery.

In order to avoid opening many small accounts all shipments will be made by Parcel-Post C. O. D. whenever possible, otherwise by express. The prices given do not cover forwarding postage, which will be included in the C. O. D. total.

Parts and accessories not given below cannot be supplied unless the instrument is sent.

### Cost of General Repair Parts and Accessories to H. & B. Instruments.

#### Tripods.

Shoes with screws, each.....	\$0.35
Leg, round or split, each.....	2.50
Head, aluminum or brass, each.....	6.00
Head, aluminum or brass with three pins, wing nuts, washers, etc., each.....	10.00
Through bolt, complete with washers, thumb nut, etc., each.....	2.00
Thumb or wing nut, each.....	.40
Wooden protection cap with brass ring, each.....	1.00
Brass ring only, for protection cap, each.....	.50
Extension leg, each.....	5.00
Clamp for extension leg, each.....	1.50
Sliding part, with steel shoe (wood), each.....	2.00

#### Box.

Transit—complete with inside packing, lock and key, side catches, four pneumatic bumpers to bottom, strap and hand grip.....	\$8.75
Level—equipped similar to the above.....	8.40
Strap with hand grip, heavy leather (singly).....	1.90
Best quality heavy sole leather carrying case with shoulder strap for transits and levels, fitted over the regular polished wood carrying box..	10.00

#### Needle.

Compass needle with cap and jewel bearing, magnetized and adjusted (see note No. 4).....	\$5.00
Center pin with holder (adjusted for height) see note No. 4.....	1.00
Compass glass for cover; clear, white French plate, ground, fitted, etc..	1.00

#### Leveling Head.

Complete with upper parallel plate and socket, four leveling screws with nuts and dust guards. Two fixed and one traveling lug; clamp screw, half ball and shifting plate, ball and socket cup to bottom of leveling screws. Lower parallel cap, with thread to attach to tripod head.....	\$28.00
--	---------

Leveling head similar to above, with regular tripod (detachable) choice of aluminum or brass head, round or split legs.....	\$40.00
Clamp screw to traveling lug.....	.75
Union angle piece.....	.35
Leveling screw with ball and socket cup affixed (see note No. 3).....	2.50
Upper dust towers to leveling screws.....	.35
Bell metal shifting plate with inside bearing for half ball.....	2.40

#### Telescope.

Sunshade for Transits and Levels.....	\$1.00
Cap for object glass.....	1.00
Cap for eye-piece, has movable shutter.....	1.75
Screw for cross wire diaphragm.....	.35
Cross wires (see note No. 1).....	Page 92
Object glasses and eye-pieces (see note No. 2).....	Page 92
Screw for adjustable stadia slide.....	.25

#### Vernier Plate and Horizontal Limb.

Long upper clamp screw (German silver).....	\$1.25
Lower clamp screw to socket (brass).....	.85
Tangent screws, upper and lower plate and to telescope (see note No. 3), each.....	1.75
Ivory vernier reflector.....	1.25
Ivory reflector with holder.....	2.00
French plate glass covers to A. & B. verniers, beveled and fitted (see note No. 5).....	1.25

#### Telescope Axle.

Right and left clamp screws with washer and end guard screw, each combination complete.....	\$1.00
German silver strip spring (solidified by pressure) to vertical telescope tangent.....	.75

#### Level Vials.

Plate level vial, graduated and of proper sensitiveness.....	\$1.00
Mounted in its tube—when latter is forwarded.....	1.50
Telescope level vial, graduated and of proper sensitiveness.....	5.00
Mounted in its tube (when latter is forwarded).....	5.50
Telescope level (Wye-Level) graduated and of proper sensitiveness.....	6.00
Mounted in its tube (when latter is forwarded).....	6.50
Capstan headed adjusting nuts.....	.25
Plate level post or pins.....	.35

#### Miscellaneous.

Adjusting levers, each.....	\$0.10
Hand magnifying glass for reading verniers.....	1.00
Waterproof bag to cover instrument.....	.75
Transit oil best quality—per bottle.....	.50
Plumb-bob (accurate) of brass with steel point (see test for plumb-bob, page 10).....	2.50
Rod level (for punning rod or pole) see page 13.....	5.00
Can of hair brush, for cleaning lenses, etc.....	.50
Buckskin for lenses.....	.35

NOTE.—The prices of above parts and accessories apply to Large, Intermediate and Small Transits, 18 inch and 11 inch Wye-Levels, as labor and cost of material is practically the same.

**Notes to the Foregoing List of Parts and Accessories Supplied  
by Parcel Post.**

No. 1. Cross and stadia wires, owing to the different focal length of the objective glasses and slightly varying magnifying power of the eye-piece, require special selection for each individual instrument. Therefore it is impossible to satisfactorily supply them without the telescope proper.

No. 2. Object glasses and eye-pieces cannot be supplied without the telescope and when practical the entire instrument should be sent.

No. 3. Leveling and tangent screws can only be supplied to fit approximately without sending the instrument. The latter being of German silver and of very fine thread is not interchangeable, but fitted to each individual instrument. Whenever possible send us the accompanying frame with nut. Should the screw supplied fit too tightly, it can be eased up by moving in and out, applying a small quantity of good oil during the operation. When done, clean thoroughly with a feather and benzine, and then lubricate with a small quantity of transit or clock oil. The local watchmaker or optician should be able to do this. Use no emery on any parts, under any circumstances or it will be ruined.

No. 4. A compass needle properly made, lasts almost indefinitely. Needle troubles usually are from three sources. First, loss of magnetism. Second, the jewel bearing becomes rough and double centered from service. This is corrected by repolishing. Third, a quick moving evenly balanced needle is dependent upon the minute sharpness of its pivot pin. By using the needle only when it is absolutely required and exercising care in raising and lowering it slowly onto the pivot pin, trouble from this source will be reduced to a minimum.

No. 5. In ordering vernier glass covers, forward us if practical the broken parts to be replaced. These vary slightly and if too large should be ground to size by a local optician.

**SOME OF THE QUESTIONS ASKED US—  
AND THE ANSWERS OUR CUSTOMERS GIVE US.**

“Can you read the time on a watch at one thousand feet with your transit telescope?”

“Do the two verniers of transit read precisely the same on the opposite sides of instrument?”

“Can as good leveling be done with the level on transit telescope as with a regular Y level?”

“Will transit stand banging around in country wagons on corduroy roads, and keep in reasonable adjustment?”

“Can regular transit be used for accurate mining surveys as well as for surface work?”

“How often must the levels and the cross-wires of telescope of transit be adjusted?”

“How accurate is stadia-work as compared with work done with a steel tape or chain?”

“How far can a transit rod be seen with your transit telescope on a clear day?”

“Dust in this section of the country wears the leveling screws and telescope slide awfully—do your dust guards prevent any wear from this cause?”

The above questions are frequently asked us—they can be best answered by Engineers and Surveyors who are using our instruments in the field—and we therefore print from our correspondence such extracts as will best answer such inquiries.

**Graduations of Transit.**

*Allen W. Haskell, C. and M. E., Birmingham, Ala.*

“With the transit I turned 90° from two measured sides of a rectangle, and the cross-wires of telescope cut a rod at a distance of a quarter of a mile.”

*W. H. Pannebaker, C. E., Virgilina, Va.*

“With transit furnished me in December, 1890, have just in town work run round a rectangle 1200 × 1800 ft., and missed my tack at



starting-point by 1-10 foot; the measuring was done by rod, with level, plumb-bob, and knife-edge. Have run round 900 X 1200, and hit tack exactly."

*Alfred Dolge*, Dolgeville, N. Y.

"With the transit you furnished me I have had a severe test of the graduations and telescope, as follows: In laying out building lots I had to stake out a straight line for about 7500 ft., on the last end down a very steep bank, through a dense wood and swamp. Coming out of the swamp, I had to make two separate offsets around farm-buildings and back to the line. I had then to set off 900 ft. at right angles, and run back parallel to the first line 3600 ft. over very broken ground, past woods and through a cemetery, necessitating frequent offsets around shrubbery, and trees."

*E. J. McCaustland*, U. S. Dep. Min. Sur., Salem, Oregon.

"With the transit I ran the exterior boundaries of a group of sixteen placer claims in the Santiam mining district in Oregon, aggregating about five miles of line and including thirty-four angles of various degrees. The angles were repeated twelve times on all portions of the plate; measurements were taken by steel tape on surface between tack points and reduced to the horizontal. Error in measurement amounted to 51-100 of a foot, and in angles too small to be appreciated."

*J. Kruttschnitt*, Gen. Mgr. Southern Pacific Co., Houston, Texas.

"Transits sent us December, 1890, and August, 1891, reached us in good order and adjustment. The closest work we have done was the location of the piers of the Pecos Viaduct in West Texas. Our assistant engineer, Mr. Kendall, had to work from a base-line of about 600 ft. in length at the bottom of a cañon some 300 ft. deep. This work tested severely not only the horizontal graduation, but also the adjustment in the vertical plane. The spans were 100 ft., made up of a tower span of 35 ft. and 65 ft. girder. The highest towers were 321 ft. from the bottom of the cañon to base of rail, and in no instance except one was the error sufficiently great to prevent the girders being set bodily on the top of the towers and the connecting-bolts entered without chipping or reaming. In the one exception there was a variation of three one-hundredths of a foot, which required slight adjustment of the bolt-holes. The cantilever span in this bridge is 185 ft., and the difference between the triangulated measurement and the actual measurement by wooden rods after completion was less than two one-hundredths of a foot. No undue expense was incurred in making these measurements, which speaks highly for the accuracy of the instruments used. I may add that when we started the construction of the bridge our resident engineer made requisition for a new transit, but in ordering I did not order the one he asked, but substituted your instrument for the

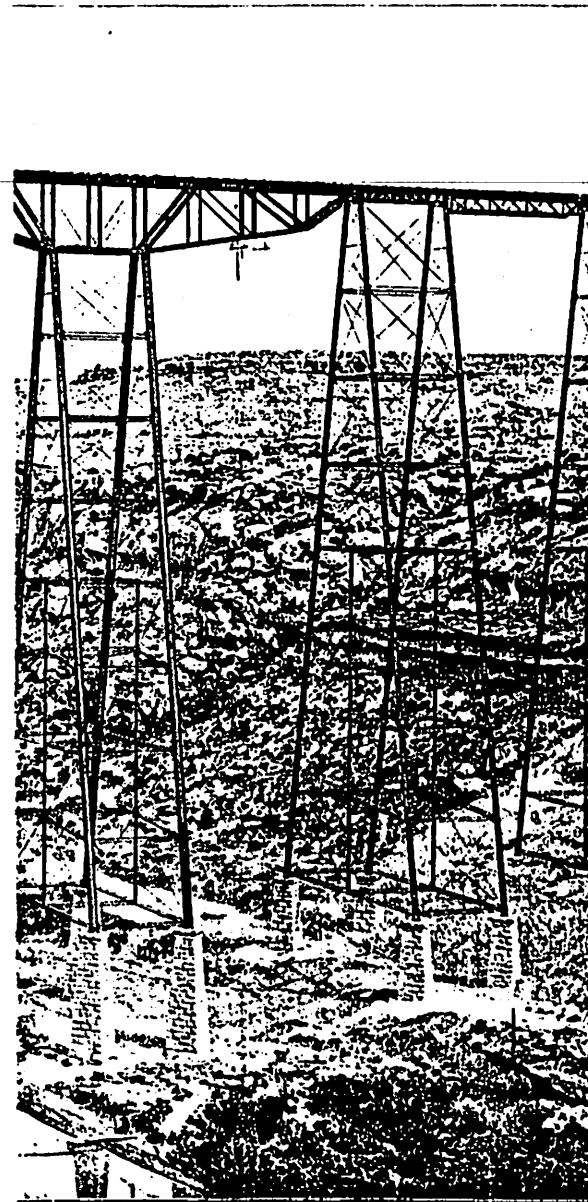

THE SAN ANTONIO RY.  
MEX. BRIDGE CO.

desired one. It began its work, therefore, handicapped by the individual preference of the engineer, yet before the work was completed I was repeatedly told that the transit left nothing to be desired."

(See cut of Pecos Viaduct.)

*G. B. Zalmiser, C. E., Mercer, Pa.:*

"I've been using transit on the C. and P. division of the Penna. Co. lines west of Pittsburg. With the instrument had a simple curve, 2300 ft. long, 'check up' on P. T. set from P. I. within one-eighth of an inch for alignment."

*D. W. Wellman, Asst. Eng. (U. S. Survey Missouri River), Waverly, Missouri:*

"Major Chas. R. Suter, Corps of Engineers U. S. A., St. Louis, Mo.:

"Major: In compliance with the request made in your letter of the 14th ult., that I give my opinion of the Heller & Brightly instruments, I would say, the assistants using the instruments on this work unaniously agree that, all points considered, they are superior to any instruments they have ever used. The telescopes are extraordinarily good, the graduations perfect, and the workmanship of such a quality that our whole five instruments have remained up to this time in as perfect condition as when they were first tried."

*W. L. Eustis, Asst. Eng. (U. S. Survey Miss. River), King's Point, above Vicksburg, Miss.:*

"Three transits received. One severe test of transit was the placing of a base-line on the Mississippi shore parallel with the base-line on Louisiana shore. The river here is one mile wide, and a right angle was turned from the upper end of base-line of Louisiana shore and plug centred on Mississippi side, where another right angle was turned, base-line measured, and plug centred. On setting over this plug and again turning a right angle, the cross-wires cut the edge of an ordinary rod held on lower end of base-line on Louisiana shore. These angles were not turned only from 0° to 90°, but from any part of the circle."

#### Range of Telescope.

*James C. Long, Min. Eng., Connellsville, Pa.*

"The atmosphere is always smoky here in the coke region, and it is pretty hard to get a fair day for a long sight, but with the telescope of my transit I am able to recognize a man at a distance of three miles—readily see a rod at ten miles also."

*W. H. Pannebaker, C. E., Virgilina, Va.*

"With my transit telescope, on favorable day, have been able to read maker's name on windmill at 4 miles; can read time on watch at 100 feet when clear and sun shining on dial."

*W. Weir Gilkeson*, City Engineer, Bristol, Pa.

"With transit, a couple of weeks since, on preliminary street work, I set a centred stone at a distance of 1800 feet. On final street work, last week, I set a centred monument at a distance of 2600 feet; and with the two ends of this line established I am now engaged in fixing the intermediate points of the cross-streets upon this line. This, in my experience, is a very long line for city final adjustment."

*Arthur E. Seamans*, C. E., Factoryville, Pa

"With the transit sent me in the spring of 1890 have set rods (metal rods, half-inch diameter) accurately at a distance of one mile. Instrument reached me in perfect order and adjustment, and has been in daily use since."

*M. H. Walker*, C. E., Green Bay, Wisconsin.

"The longest range I have had occasion to take with the transit you sent me in 1890 was in July of this year. I was running a line between two section corners 2 miles apart, and for  $1\frac{1}{2}$  miles the ground was rising. There was a  $\frac{3}{4}$ -inch rod at my starting point (the section corner), and I was at the  $\frac{1}{4}$  post,  $1\frac{1}{2}$  miles S. from it, from which the ground sloped both ways, and I had  $\frac{1}{2}$  mile farther to run. I took a back-sight to my rod,  $1\frac{1}{2}$  miles away, and bisected it with my vertical wire as satisfactorily as if it had been only 300 feet."

*O. M. Hoge*, City Engineer, Cambridge, Ohio.

"Just how far objects can be seen with my transit telescope I cannot say, but I have read the time on an ordinary watch 1000 feet distant. The hills here are very favorable for long sighting."

*Geo. B. Spangler*, County Surveyor, Atchison, Kansas.

"Transit you sent in February reached me in perfect order and adjustment, and is so yet, although in constant use. The telescope is a very clear and powerful one, and I have been able to recognize a person  $5\frac{1}{2}$  or 6 miles—of course by general appearance and movements in walking."

*M. G. Lisher*, City Engineer, Vancouver, Washington.

"I have not yet found the limit to the range of my transit telescope, as about 4000 feet is the greatest distance to which I have had occasion to line a flag-pole. At that distance the flag was clear and distinct. Another advantage it has over any other telescope I have ever used, and that is, field work can be commenced earlier and continued later than usual; for while there is light enough to read angles, there is light enough to see the cross-wires and objects beyond."

*Alfred Gobalet*, Civil Engineer, Salem, Oregon.

"While doing some work last May, directing the telescope on a snow-covered mountain-side 30 miles distant, am certain that I could have distinguished a man from any other object, as objects no larger than a man were clearly defined."

*Wm. B. Hanlon*, Chief Eng. C. L. and W. R. R., New Philadelphia, Ohio.

"With my transit telescope I have read the time to a minute on a town clock three and a half miles away."

*J. J. Treveres*, Civil Engineer, Jacksonville, Florida:

"With my transit telescope I can clearly, without shimmering or blurring, see my aligning-pole one mile."

*E. H. Stephens*, Civil Engineer, Louisville, Kentucky:

"I have had no difficulty at all in observing the movements of Jupiter's moons for several evenings in succession with my transit telescope."

*W. F. McClure*, Civil Engineer, Los Angeles, California:

"The first day I took the transit out I looked with great pleasure at the snow on the pine branches in the mountains 25 miles from where I stood in a bevy of wild flowers, surrounded by orange-orchards."

*A. A. Titsworth*, Asst. Eng. U. S. Coast Survey, Hamburgh, N. J.:

"In running a straight line from the Pochuck to the Blue Mountains last week (running boundary line between New York and New Jersey), when I reached the Blue Mountains, to extend the line beyond on the other side, I had for a back sight five signals, all in a perfectly straight line on the different hill-tops between, the most distant being on the Pochuck, nine miles back."

*C. P. Burgwyn*, U. S. Eng., Barge Dismal, off North Landing River, Dismal Swamp, Virginia:

"I have to distinguish the colors on the flags at long distances—sometimes over four miles; and as each flag has a particular number, determined by its color, the magnificent power of the transit telescope I am using on this particular work is of very great importance."

### Mining Transit.

*James C. Long*, Mining Engineer, Connellsville, Pa.

"A great advantage I find in the telescope of the transit I purchased from you in March, 1891, is that in mine work it will collect enough rays of light from an ordinary miner's lamp, at a distance of four or five hundred feet, to illuminate the cross-wires without the aid of an extra lamp for that purpose. The lettering between the cardinal points on the graduated horizontal plate is also an advantage over all transits I have seen, as it enables one to read the course direct from the plate, without the trouble of calculation."

*Flat-Top Coal Land Asso., F. L. Paddock, Chief Eng., Bramwell, W. Va.*

"Transit has been used for both inside and outside work—a mine survey of 70 stations checking to the minute, and an outside survey of 108 stations to within less than two minutes."

*O. M. Hoge, City Engineer, Cambridge, Ohio.*

"In my mine work, some twelve months ago (with the transit you sent me some two and a half years ago), I located an entry one-half mile long where close work was particularly desired on account of the peculiarity of the land. A few weeks ago we sunk a shaft on the line of the entry about 2000 feet from the opening, and after testing the alignment it was found to be correct within less than an inch. This was a severe test of the accuracy of the graduation of the horizontal limb, as there were several angles in the entry which had to be made and reproduced."

*Wm. B. Hanlon, Chief Engineer C. L. and W. R. R., New Philadelphia, Ohio:*

"My transit has been used in the mines a great deal, and of course has lost some of its fine appearance, but its work is as accurate as ever. It has the same good quality of holding all its adjustments as the other two H. & B. transits I have used."

*Chas. F. Hoffman, Mining Engineer, Virginia City, Nevada:*

"Am establishing the disputed boundary line between the Union and Sierra Nevada mines above ground, as well as on the 1700, 2200 and 2300 feet levels. The transit is the best one I ever used."

*Sutro Tunnel Surveying, —, Nevada:*

"There has been recently completed a very important survey for the north and south lateral branches of the Sutro Tunnel. The instructions to the engineer, Chas. F. Hoffman, were to ascertain the bearings and distances from a given point in the main Sutro Tunnel (about 19,300 feet from its mouth) to a Sierra Nevada shaft, thence to a point in the Julia drift and near the Julia shaft to a point 80 feet east of the Yellow Jacket shaft, and thence to a point 200 feet west of the new Overman shaft. He first had to ascertain the relative positions of all the shafts mentioned on the surface, thence to transfer a line underground corresponding to a given line on the surface, so as to be able to turn off any required angle underground. This work being one of great magnitude, and requiring more than ordinary accuracy, besides the country being not only very rough, but obstructed by the buildings of Virginia City, he had to resort to triangulation and traverse, one as a check upon the other. The station points on the surface were marked by steel drills driven into the ground even with the surface and afterward covered with a mound of rock, so they may be found and used for future surveys. The principal stations in the tunnel were marked by centres in

solid rock placed in the roof of the tunnel. The instrument used in making this survey was a transit manufactured by Heller & Brightly in Philadelphia."—*Engineering News.*

*J. Parke Channing, Mining Engineer, Iron Mountain, Mich.*

"With the first transit sent me, in 1886, at Bessemer, Mich., when it was four years old, I laid out a full-timbered, three-compartment inclined shaft from surface and from a level 200 ft. under ground. These connected so close on pitch that there was no appreciable error, and the centre lines from the top and bottom came out parallel, and only one one-hundredth of a foot apart. Started from the surface of the new shaft, ran 500 ft. in surface (three rights), down an underlay shaft 200 ft., 500 back through the level, with seven courses. Had to calculate horizontal and vertical angles on every course. With the second transit that you furnished me, July, 1890, at Ishpenning, Mich., for the East New York Mining Co., I subdivided a section, read angles at the section corners twelve times, and the survey closed within a very few seconds. Took several sights of half a mile on this work; one of three-quarters."

#### Permanency of Adjustments.

*P. Julian Latham, C. E., Washington, D. C.*

"The transit I got of you over a year ago I used on preliminary and location in a railroad in the Adirondacks, where the country was very rough, but both the cross-wires and levels are still in perfect adjustment."

*J. C. Long, Min. Eng., Connellsville, Pa.*

"The instrument has been used constantly for all kinds of work in very rough country in the coke region, and all the adjustments are excellent, the cross-wires especially."

*Allen W. Haskell, C. and M. E., Birmingham, Ala.*

"Both transits (one in 1887, one in 1890) reached me in good adjustment, and I don't recollect ever being called on to adjust either. My policy is to let the adjusting screws alone if all is right."

*R. E. Ricker, Gen. Supt. St. Louis I. M. and S. Railway, St. Louis.*

"Transit you sent me last winter is yet in perfect adjustment. I have tested its adjustments in every possible way, and I have not as yet had occasion to change a single one of them."

*E. J. McCausland, U. S. Dep. Min. Sur., Salem, Oregon.*

"The two instruments (transit and level) sent me in the spring of 1888 reached me in perfect adjustment in all parts, and are so yet."

*C. Loomis Allen*, C. E., Syracuse, N. Y.

"Transit reached me O. K., and shows no signs of any adjustments being the least out in seven months' constant use."

*Ira O. Baker*, Prof. C. E., University of Illinois, Champaign, Ill.

"Neither the cross-hairs nor levels of the transit bought by the University over two years ago have lost their adjustments, notwithstanding it has been in constant use by the students."

*J. M. Bell*, Civil Engineer, Indianapolis, Indiana.

"My transit was received in perfect order and adjustment, and remains so yet."

*Blair Burwell*, Chief Eng. Florida Central Railroad, Jacksonville, Fla.

"Transit received of you in 1891 came in good condition and adjustment; have touched none of the adjustments since."

*L. F. Prevost*, C. E., Lima, Ohio.

"One point in the transit you sent me two years ago I desire to mention. I level up the level of telescope for leveling; it can then be turned in any direction without releveled. This speaks well for the instrument, considering the extreme sensitiveness of the large level. Many Chicago engineers have asked me very particularly about this point."

*B. H. Tatem*, Min. Dir. Bald Butte Mining Co., Helena, Montana.

"Transit shipped me September, 1891, reached me in not only fair but in perfect adjustment, and I have not had to touch it for adjusting since its receipt. I always test it before use, to satisfy myself as to its correctness."

*O. M. Hoge*, City Engineer, Cambridge, Ohio.

"Transit sent me two and a half years ago reached me in perfect order and adjustment, and has been so ever since, although constantly in use. Our country is quite hilly here, and in going to the mines and country the transit is generally transported in a buggy. This of itself is enough, over these rough hills and worse roads, to rack an instrument to death."

MAJ. WM. P. ROSSELL,

U. S. ENGINEER'S OFFICE,  
MOBILE, Ala.

*Heller & Brightly*:

"The new Transits (for improvement Tombigee River, Alabama), are very satisfactory; tried them for adjustments and found them correct. They reverse at 180 degrees at the long range of one thousand feet (1000 feet), something not always found."

U. S. LIGHT HOUSE BOARD.

PHILADELPHIA

*Heller & Brightly*:

"The Transit of your make was used by me for the last three years on work for the Light House Board, which took me to the Great Lakes and along both sea coasts. Exposure to salt air did not affect the clearness of the telescope, and it bears transportation and holds its adjustments excellently well.

H. BAMBER,

"Assistant Engineer U. S. L. H. Service."

*A. B. Gill*, C. E., Berkeley, Virginia:

"When transit reached me, found it perfect adjustment, and it is so yet. Although I had it in a boat and it rolled a number of times from side to side, this rough treatment did not alter it in the least."

*J. Parke Channing*, Mining Engineer, Michigan:

"I took your transit last month to Mexico and back—5000 miles on railroad, stage, and mule-back—and it never lost any of its adjustments, not even the bubble-tubes."

*J. V. Bergen*, Mining Engineer, Tombstone, Arizona:

"Transit has been in constant use for over a year. It has been packed on burros, jolted in a rough wagon, carried on horseback, been exposed to rain, snow and hail, but not a single screw was ever touched with the adjusting-pin, and all adjustments are still perfect."

*Wm. H. Lawton, Jr.*, Civil Engineer, Newport, R. I.:

"Transit I purchased two years ago still remains in perfect adjustment."

*Prof. A. J. DuBois*, Sheffield Sc. School, Yale College, New Haven, Conn.:

"The four transits and levels not only give satisfaction; they are the best we have, and better than any I have seen by any other maker."

*J. Geo. Garneau*, C. E., Quebec Water Works, Quebec, Canada:

"Level reached me, after its long railroad journey, with none of its adjustments in the least altered."

*John M. Walker*, C. E. (Kansas City, F. S. and M. R. R.), West Plains, Missouri:

"With the transit have run about six hundred miles of line over some of the roughest country of the Boston and Ozark Mountains of Missouri and Arkansas. The instrument has been carried in heavy wagons over the same country in the box, and I never as yet had to touch the adjustments in any particular."

*H. W. N. Cole*, Con. Eng., Yuscaran Mining Co., Yuscaran, Honduras, Central America:

"All the adjustments of my transit were correct when I first used it; and when the miles of rough travel it had gone through are taken into account, the test was rather a severe one. I was eleven days going from the coast to this place, with the transit shaken up and down on the back of a mule."

**Close Leveling Work.**

*A. M. Bannister*, Civil Engineer, Farwell, Mich.:

"I have just taken 40 miles of levels for the T. A. A. and M. R. R. with my H. & B. Level, using an open-faced rod and reading my own rod through the telescope. We ran three lines from Marion to Fal-mouth, and I took bench-marks every 1500 ft. In some 18 miles of the line we had to make a change of level from the bottom of the rivers to the tops of a rolling country of over 100 ft."

*J. O. Davis*, Civil Engineer, Houston, Texas:

"With the level on my transit telescope I have just run a line of levels six miles, closing on my starting B. M. with an error of one one-hundredth of a foot."

*F. A. Camp*, Eng. Tionesta Valley R. R., Sheffield, Pa.:

"With my Level I can read a painted rod 'to hundredths' without a target at a distance of 1200 feet with ease, and did so several times on a line of six miles and return, and checked up on first bench within one-tenth."

*Wm. McC. Ransom*, U. S. Civil Engineer, New London, Conn.:

"With my level I have run a distance of three miles between two U. S. Coast Survey benches and checked up in .007."

*Prof. John C. Branner*, Indiana University, Bloomington, Ind.:

"For nearly a year I have put the Level to the severest of tests. The geological maps I am constructing of this region are based hypso-metrically upon the transcontinental level line of the U. S. Coast Survey. In carrying the levels of the Coast Survey from Mitchell in this state to Bloomington, a distance of 36 miles, the error was less than two inches. The same line, run with a level made by — of —, had an error in it of .14 feet."

*W. L. Eustis*, Asst. Eng. (U. S. Survey Miss. River), King's Point, above Vicksburg, Miss.:

"With the Level we located a bench-mark across the Mississippi River—one mile sight. It was first seen that instrument was in adjust-ment, and numerous rods taken on bench across the river. Next, all parts of instrument were thrown far out of adjustment, then by the five

reversals, to kill all errors of adjustment and make, rods were again taken on the same bench (in sets of five). The difference of tang. plane, given by level in adj. and near reversals, was 0.001 of a foot. This proved that there were no 'instrumental errors,' and the only source of inaccuracy was in precisely setting a target at such a long sight. These observations were taken at night in January, thermometer being 15° below freezing, and also in June, at 87°, with the same results."

*E. M. Capps*, Civil Engineer, San Diego, Cal.:

"While making the surveys of the Massac Flume line in Lower California, was reluctantly forced to use the level on my transit telescope in the location of about three miles of the line, owing to damages to my Y level. On checking the work with a Y level I was surprised to find an error of only one-tenth of a foot."

*A. Stierle*, Asst. Eng., U. S. Eng. Office, Philada., Pa.:

"Mr. Cox, who uses your Level, has finished the line of levels from League Island to Bridesburg (about 13 miles). He makes a difference of only .04 of a foot in the references of the two bench-marks at the ends of the line, compared with the results obtained by the U. S. Coast Survey a few years ago. Mr. Fillebrown, who ran over the same line lately with a Level made by —, made the upper B. M. 1½ tenths lower."

**Leveling in 1824, and Leveling at the Present Time:**

"In the annals of the State of Pennsylvania (Pennsylvania State Improvements—main line) it is mentioned as a remarkable specimen of unusually accurate leveling that in a circle of 12 miles that was leveled the error was only one foot and two-tenths. This was in 1824. United States engineers are engaged at present in running a line of levels between the Chesapeake and Delaware Bays for the purpose of determining the feasibility of a ship-canal. In testing new Leveling instruments furnished by the United States for the work (Heller & Brightly make), a line of test-levels was run of over 10 miles, and the difference of level on the closing bench-mark was only five thousandths of a foot (0.005)." — *Engineering and Mining Journal*.

**Accuracy of Stadia Wires in Telescopes.**

*L. R. Harris*, Civil Engineer, San Diego, Cal.:

"Have just completed a stadia survey and subdivision of 4800 acres, and the stadia work turned out very much more satisfactory than the chaining."

*Donald W. Campbell*, U. S. Eng., U. S. Survey Miss. River, Glasgow, Mo.:

"Have closed an eleven-mile line round a bend of the river with an error of only 37 feet lat. and 23 dep. stadia measurements, as compared with the co-ordinates of our triangulation survey."

*John S. Eastwood*, Civil Engineer, Fresno, California:

"With the transit have just run a preliminary railroad line up a steep and rocky canyon, where I took the angles of intersection, magnetic bearing, distance with stadia, levels by vertical angles and bubble, the slope angles, and topography, all at one setting of the transit, and with a party of four men besides myself. Owing to the efficiency of the instrument, was enabled to make as rapid progress as I have made under similar circumstances with twelve men."

*A. A. Titsworth*, Asst. Eng. U. S. Coast Survey, Hamburg, N. J.:

"While running the boundary-line between New York and New Jersey with H. & B. transit I used stadia measurements. The longest stadia sight I took during the survey was 1886 feet. At one place on the line, between the 23d and 24th mile-stones, in a distance of 4160.2 feet, measured by a series of stadia readings over a very rough country, after which, in triangulating back, it agreed to within two-tenths of a foot (4160). We reduced all stadia readings to true readings by multiplying the reading by  $\cos^2$  of the vertical angle. I have no hesitancy in saying that in a rough and monotonous country, like the most of that along the above-mentioned line, the stadia, as compared with chaining, is much more expeditious, convenient and accurate. It requires, however, a well-defining telescope, and your improved telescopes are just the thing for that kind of work. Their defining power is excellent."

*Geo. W. Roper*, Supt., Roper, N. C.

"With the transit sent me four years ago I make good use of the stadia in telescope, and have done excellent work, equal to any."

*O. M. Hoge*, City Engineer, Cambridge, Ohio.

"The stadia-wires give good results, besides the quickness with which they can be used."

*Wm. W. Redfield*, C. E., Minneapolis, Minn.

"I have meandered a lake on the ice, with 2000-foot sights, and read the space covered on a ten-foot rod by either the upper or lower two horizontal wires with perfect facility."

*Wm. H. Leffingwell*, U. S. Geol. Survey (Rocky Mountain Division), Denver, Colorado:

"Am using the small mining and reconnaissance transit for stadia-work. In a line of about three miles, the ends of which were checked by triangulation, I have been unable to detect an error of seven feet in the entire length. As the line was partly run in quite cold weather and with snow some five and six feet deep (with 34 stations), the result is much more satisfactory than could be expected."

Value of Dust and Rain-Guards.

*Geo. H. Lyman*, C. E., Fort Smith, Arkansas.

"The dust-guards (on leveling and tangent screws and telescope slide) have entirely prevented any trouble from dust. These parts work as freely and truly as when I first got the transit from you, in 1884."

*German Warner*, C. E., Greenville, Ohio.

"Thanks to the dust-guards, the telescope slide, leveling screws, etc., on my transit (bought Nov., 1890,) work smoothly and truly yet."

*Geo. W. Roper*, Supt., Roper, N. C.

"The dust-guards are indispensable in this dusty section."

*Ino. M. Taylor*, C. E., Idaho Falls, Idaho.

"Both transits (one in 1882, the other in 1890) reached me in excellent condition. This climate is extremely dry and dusty, but the dust-guards have prevented all trouble from that source."

*L. F. Prevost*, C. E., Lima, Ohio.

"The transit sent me over two years ago reached me in good order and adjustment, and, although used constantly since, remains so. Would especially mention that the dust-guards protect the telescope, leveling screws, etc., and I have never had the slightest trouble from dust or dampness inside of telescope, and I have used it in some very misty and wet weather."

*Arthur E. Seamans*, C. E., Factoryville, Pa.

"The various dust-guards on transit (sent spring of 1890) are just the thing, and, since I know their value by experience, I would not have an instrument without them."

*O. M. Hoge*, City Engineer, Cambridge, Ohio.

"The dust-guards on transit (sent Jan., 1890) are all O. K. No dust has troubled me. The compass needle is extremely sensitive yet, and I frequently use it in land surveying with the best results."

*M. G. Lisher*, City Engineer, Vancouver, Washington.

"The first work done with the transit and level took 35 days. On 29 of these rain fell heavily, and the instruments were wet all the time, but the telescope and verniers were perfectly clear all the time. No other make of instrument that I have used would have given satisfaction under these conditions."

*D. W. Campbell*, Asst. U. S. Eng., U. S. Survey Miss. River, Leavenworth, Kansas:

"The transit kept its adjustment under very trying circumstances. I was frequently for hours exposed to a gale of wind near the cut edge of a sand-bar, when I would have to wait two, three and sometimes five minutes, with my eyes shut, for a lull to take a sight, unable to see a man 100 feet distant, and with the sand pouring on my instrument like a sand-blast, but the centres, telescope, and screws were so well protected by the dust-guards that when I last took the instrument to pieces I could not detect a scratch, and my last day's work was as satisfactory as the first."

J. S. Eastwood, C. E., Fresno, California:

"Your instruments are better adapted to California climate than any other make, owing to the complete shielding from dust of all the important part by 'dust-guards.'"

F. S. Bowen, Asst. Eng. Union Pacific Railway, Soda Springs, Idaho:

"Transit received in perfect adjustment. The dust-guards to leveling- and tangent-screws and telescope-slide are an absolute necessity in this dusty country."

W. L. Eustis, Asst. U. S. Eng., U. S. Survey Miss. River, King's Point, above Vicksburg, Miss.:

"During windy weather the fine white sand came in clouds from the sand-bars. The dust-guards to the telescope-slide, leveling-screws, tangent-screws, etc., prevented any binding or wearing on these important parts."

Accuracy of Compass-Needle.

E. J. McCaustland, U. S. Dep. Min. Sur., Salem, Oregon.

"Compass-needle of my transit is still very sensitive, and shows no signs of sluggishness after almost five years' constant use."

James B. Gass, City Engineer, Fort Smith, Arkansas.

"The adjustments of transit hold splendidly, and the needle is as sensitive as when first bought."

J. H. Beach, Civil Engineer, Spencerville, Ohio.

"The compass-needle of the transit was very sensitive when first received, and the adjustments of instrument were all perfect. Needle and adjustments still remain the same."

W. R. Garrett, Civil Engineer, Beeville, Texas.

"Transit used a year; arrived in good order and adjustment. The compass-needle is superior to anything I ever saw. How much would you charge to put a new needle and centre-pin on a ——— transit?"

Geo. H. Lyman, Civil Engineer, Fort Smith, Arkansas.

"The compass-needle of transit has been used since 1884, and is still as sensitive as when it came from the factory, and I do good work with it."

Safety of Packing in Transportation.

Alfred Dolge, Dolgeville, New York.

"We live eight miles from the nearest railroad station, and when I received the transit in the spring the roads were in a terrible condition, and the instrument received very hard knocks in transit over the roads. Adjustments were uninjured."

Alfred Gobalet, Civil Engineer, Salem, Oregon.

"The transit sent me April, 1890, reached me in very good adjustment, and, considering the long voyage and the round-about way to reach me on account of direct transportation having been interrupted at the time by the flood, I think the packing was well done."

W. L. Stellwag, Civil Engineer, Oakville, Missouri.

"Transit sent me Feb., 1891, was received in good condition, and all the adjustments were exact and perfect. Have used it almost every day since, and carry it over very rough roads, and none of the adjustments have altered in the least."

M. G. Lisher, City Engineer, Vancouver, Washington.

"The transit and level got in March, 1891, arrived here after their long journey in such good condition and adjustment that your mode of packing would justify any one in ordering them shipped by express at single rate."

DEPARTMENT OF THE INTERIOR,  
U. S. INDIAN SERVICE,  
FARMINGTON, New Mexico.

Heller & Brightly:

Received the new Transit and Level in perfect order after their journey of over twenty-four hundred miles. After leaving the Express Office in Durango, Col., the instruments traveled about sixty miles by wagon, over rough roads, and in an ordinary freight wagon at that, without springs and heavily loaded. On testing Transit and Level after unpacking, found that all the adjustments on both instruments were still perfect. The condition in which the instruments reached me after their long journey speaks well for your system of packing.

E. C. VINCENT,  
Supt. and Special Disbg. Agent.

The above Transit and Level traveled 2404 miles (see below). After leaving Philadelphia they made six changes of cars (transfers) at the following places: At Pittsburg, Pa.; Chicago, Ill.; Pacific Junction; Denver, Col.; Salida, Col., and Durango, Col.

Philadelphia to Pittsburg.....	354 miles
Pittsburg to Chicago.....	468 "
Chicago to Denver (via Pacific Junction)....	1020 "
Denver to Durango (via Salida).....	502 "
Durango to Farmington (by wagon).....	60 "

2404

J. B. Hogg, Civil Engineer, Port Townsend, Wash.

"The three instruments (two transits and one level) purchased of you in the last five years all reached me in good order and adjustment."

Geo. Bentley, Supt. Western Coal and Mining Co., McFerran, Colo.:

"Instruments received after their long journey in perfect order and adjustment."



*B. M. Harrod*, C. S. Eng. Office Board State Eng., New Orleans, La.:

"Transit purchased for this office has given entire satisfaction. No trouble with its adjustments. We work much on top of levees, exposed to high winds, and the instrument has been found to be very stable."

*A. S. Gates*, U. S. Dep. Sur., Spearfish, Dakota:

"Transit and level reached me in good order and perfect adjustment."

*Henry Custer*, U. S. Eng. Camp, Kankakee River, Illinois:

"Level reached us nicely adjusted, and this adjustment has even stood the test of peculiar adjustments which are not generally applied to leveling instruments."

*John C. F. Randolph*, Consulting Mining Engineer, New York. Batopilas, State of Chihuahua, Mexico:

"Messrs. Heller & Brightly, Philada., Pa.:

"Gentlemen: You had so little time to pack my transit and level of your make that it will interest you to know that they have come safe and sound through a most difficult journey. They were expressed from New York to Sante Fé, and from there went 600 miles by stage and wagons without springs to Chihuahua, enduring on the road one serious stage upset. From Chihuahua the transit was carried 200 miles on the back of an Indian, and for lack of another Indian the level came on mule-back. It pleases me to inform you that the instruments are uninjured, but also not out of adjustment. You know how to pack a good instrument as well as to make it. Yours, etc.,

"JOHN C. F. RANDOLPH."

*James M. Hamilton*, C. E., Upper Crossing, Price River, Utah:

"Transit when unpacked here, after its journey from Philadelphia and its ride of 100 miles over the roughest of mountain roads, was found in good adjustment in all its parts; also the level; also the other transit and level."

*Nathaniel Robbins*, U. S. Dep. Sur., Cheyenne Nation, Indian Territory:

"Transit reached me at Hays City, after its long journey from Philadelphia. I tested all the adjustments by every test, and found them perfect. I then loaded it into a freight wagon and hauled it over 400 miles, over rough roads, to this country, and have done five weeks' hard work with it, and to-day tested it again, and found all the adjustments as good as when it first came to me at Hays City."

*Edmund Wilkes*, U. S. Dep. Sur., Salt Lake City, Utah:

"Transit has been turned over twice down mountains, but, thanks to your perfect arrangement of box, it has kept all its adjustments."

*Bruce L. Meloy*, Civil Engineer, Altoona, Pa. May 19, 1915.

"Perhaps it would not be out of order for me to tell you at this time of a few tests I have made of the accuracy of my H. & B. Transit No. 6264. I recently ran a stadia line along the upper course of the Juniata River on a topographical survey. The line depended upon needle courses, stadia distances, vertical angles and was run during the marshy spring weather.

"I kept my own notes, used an ordinary leveling rod for the work, and beginning at a point we made a circuit of about four miles of line, some distances being only ten feet, some as great as one thousand feet. The line was plotted on a scale of 1 inch to 200 feet, and on plotting the line clear around to the point of beginning we checked up within 5/1000 of a foot for elevation and plotted to the exact needlepoint for line.

"Another piece of stadia work on a smaller circuit, but plotted on a scale of 1 inch to 10 feet, checked up perfect for both elevation and line.

"As to the power of the telescope, a little incident that happened recently might be of interest to you.

"At a military camp a detachment was sent to a mountain top one and a half miles distant. I watched the "wig wag" signals through my transit telescope and caught every letter.

"In ordinary field work I can depend on the results obtained with this instrument and I cannot say the same of either of the two instruments made by other companies which I have used."

*John G. Gault*, Assistant Highway Engineer, Middlesboro, Ky. August 3, 1915.

"Just a few words in regards to the instrument purchased from you a few weeks past, to let you know that I have tried her out in every respect and find her perfect—and the telescope can't be beat. I made one triangulation of over three miles—and could see my rod as plain as at five hundred feet, or thirty—and if she fails to check—I know it's the man—not the instrument; in short it's the only transit I ever used and that covers several different makes."

*A. Langlois*, Assistant Engineer, St. Lawrence River District, and in charge of Rainy River Survey. Ottawa, Canada. Nov. 21, 1913.

"You are hereby authorized to go ahead with the repairs to the transit No. 7602, I sent you some time ago. We want this instrument put in the very best of shape.

"About the standing of your instruments in this department, I must say that they are regarded by every one who has used them here, as being the most precise instrument made.

"Your transits have been used on the French River, which is part of the Georgian Bay Canal Survey, and the French River Survey was probably the closest ever made in North America.

"Your transits have been used here right along for the last 15 years and are at present time used on surveys at Kingston, Ont., for the St. Lawrence River Channel, etc., and by myself on the Rainy River Survey and I am pleased with the two I am using."

Chas S. Hill, Civil Engineer, Palmetto, Florida. Jan. 26, 1915. "Your level No. 8059 came to hand yesterday, thanks for your promptness and to say the least, I am highly pleased with it.

"I have the contract to do the engineering on what is known as the Gamble Creek Drains, comprising about twenty-two miles of main drain and seven laterals, reclaiming about 30,000 acres of land and I shall use your Transit No. 7978 and your Level No. 8059 to do the work with.

"I didn't buy your instruments from hearsay, or upon some one else's recommendation, but because I have used them before and always preferred them to any other make I have ever used.

"However, all engineers are not alike, for if they were, no one else would be able to sell instruments but Heller & Brightly, and that would create a monopoly."

W. H. Newson Engineering Co., W. H. Newson, Wynne, Ark. April 9, 1915.

"I have one of your Complete Transits, made for me in 1904, and it is as good to-day as ever, and we would not exchange it for any new Transit of any make."

Geo. McC. Taylor, Civil Engineer, Red Bank, N. J. Aug. 16, 1915.

Will you send me price of Transit Extension Tripod. The number of the Transit is 4808. This Transit was purchased from you by me in the spring of 1878 or 1879. It has thus been continuously used for about 36 years, and is still as good and correct as the best of new ones."

To Colleges and Universities.

We make a specialty of furnishing field instruments (Transits, Levels, etc.) for the purpose of instruction in Universities and Colleges. Below is a list of Colleges to which we have furnished such field instruments:

- Polytechnic College Philadelphia, Pa.
Columbia College (School of Mines) New York City, N. Y.
Dartmouth College New Hampshire.
Princeton College New Jersey.
University of Pennsylvania (Towne Scientific School) Philadelphia, Pa.
Lafayette College Easton, Pa.
Massachusetts Institute of Technology Boston, Mass.
Yale College (Sheffield Scientific School) New Haven, Conn.
Lehigh University Bethlehem, Pa.
Maine State College Orono, Maine.
Fiske University Nashville, Tenn.
Imperial College Tokio, Japan.
Western University Pittsburg, Pa.
Delaware State College Newark, Del.
Tuft's College College Hill, Mass.
Pennsylvania State College Pennsylvania.
Washington and Lee University Lexington, Va.
Indiana State University Indiana.
Oregon State College Oregon.

- California State College California.
University of Minnesota Minnesota.
Michigan State Mining School Houghton, Mich.
Colorado State College Colorado.
University of Alabama Tuscaloosa, Ala.
Philadelphia High School Philadelphia, Pa.
Haverford College Philadelphia, Pa.
Cornell University Ithaca, New York.
Delaware State College Dover, Del.
University of Illinois Champaign, Ill.
Louisiana State University Baton, Rouge, La.
University of Illinois (Mining Engineering Dept.) Urbana, Ill.
Virginia Military Institute Lexington, Va.
Ohio Normal University Ada, Ohio.
Colliery Engineer School of Mines Scranton, Pa.
Philadelphia Manual Training College Philadelphia, Pa.
State Normal School West Chester, Pa.
University of Wisconsin Madison, Wis.
University of Idaho Moscow, Idaho.
Arkansas Industrial University Fayetteville, Ark.
University of Texas Austin, Texas.
Adelphi Academy Brooklyn, N. Y.
Louisville High School Louisville, Ky.
Pennsylvania State College (Dept. of Mining Eng'g) Pennsylvania.
Ohio State University Columbus, Ohio.
John B. Stetson University De Land, Florida.
Drexel Institute Philadelphia, Pa.
Custer Institute Custer, Ohio.
Homestead College Homestead, Pa.
State School of Mines Golden, Colorado.
University of Washington Seattle, Wash.
Purdue University Lafayette, Ind.
Hamilton College Clinton, N. Y.
Vanderbilt University Nashville, Tenn.
Kansas State Agricultural College Manhattan, Kansas.
Armour Institute Chicago, Ill.
Stanford University San Francisco, Cal.
Delaware College Newark, Delaware.
New York State Normal School Buffalo, N. Y.
University of Iowa Iowa City, Iowa.
Alfred University Alfred, N. Y.
Oregon Agricultural College Corvallis, Oregon.
Washington and Jefferson College Washington, Pa.

The Largest College Order For Surveying Instruments Ever Given in the United States.

COLUMBIA COLLEGE (SCHOOL OF MINES).

The new course of studies in the School of Mines of Columbia College (New York City), as mapped out by the authorities, will require a decided increase in the number of field instruments as compared with those heretofore used. When fully organized, thirty-eight transits, levels and plane-tables will be required, the cost for these three items alone amounting to over eighty-three hundred dollars. Messrs. Heller & Brightly, of Philadelphia, who furnished the field instruments for the

University of Pennsylvania, Princeton College, Dartmouth College, the University of California, etc., have also received the contract for furnishing these instruments to Columbia College.

Engineer and Mining Journal, New York,

One of the largest orders which has been given in this country for surveying instruments was recently given by Columbia College, of this city, to the well-known manufacturers, Messrs. Heller & Brightly, of Philadelphia. The first installment of this order, consisting of eight combined transit and leveling instruments, four Y-levels and four plane-tables, has just been delivered. The requirement of the School of Mines, under the "new departure" inaugurated by Professors Trowbridge and Monroe, will call for over three dozen transits, levels and plane-tables.

*Ira O. Baker*, Prof. C. E., University of Illinois, Champaign, Ill.:

"Neither the cross-hairs nor levels of the transit bought by the University over two years ago has lost its adjustments, notwithstanding it has been in constant use by the students."

IRA O. BAKER, Prof. Civil Engineering.

*Prof. A. J. DuBois*, Sheffield Scientific School, Yale College, New Haven, Conn.:

"The four transits and levels not only give satisfaction; they are the best we have, and better than any I have seen by any other maker."

Prof. A. J. DuBois, Dept. Civil Engineering.

*Prof. John C. Branner*, Indiana University, Bloomington, Ill.:

"For nearly a year I have put the level to the severest of tests. The geological maps I am constructing of this region are based hypsometrically upon the transcontinental level line of the U. S. Coast Survey. In carrying the levels of the Coast Survey from Mitchell, in this State, to Bloomington, a distance of 36 miles, the error was less than two inches. The same line, run with a level made by — of —, had an error in it of 14 feet."

Prof. JOHN C. BRANNER.

*Colliery Engineer, School of Mines, Scranton, Pa.:*

"Transit of the Correspondence School of Mines proves very satisfactory, and does the same accurate work as the other instruments of your make that I have used. The dust guards do excellent service. The graduations of the horizontal limb are accurate, and the needle very sensitive. When we need another Transit we will certainly purchase a duplicate of the one you made us."

RUFUS J. FOSTER, President Colliery Eng. Co.

## INFORMATION TO PURCHASERS.

As we have only one grade of goods, and one price, and never deviate from either, it is not absolutely necessary for parties to apply to us in person for the purpose of purchasing or selecting any of our instruments.

The modern system of Express Agencies is now so complete as to have their agents at every important point in the United States and British America, and these agents in their turn forwarding by stage, etc., to places where there is no Express agency. This Express system renders it safer and more expeditious at the present day to send goods one thousand miles than to have sent them thirty miles away twenty years since.

As to the good condition and safety of the instruments that may be transported by express, we pack in such a manner, and make such provision for their safe transportation, that we guarantee the good condition of the instruments on their arrival at their place of destination, after being forwarded by express; and hold the express company liable to us for all loss or damage that may be incurred on the way.

It is perhaps unnecessary to say that we warrant the instruments, in all their parts, to be made of good material and of good workmanship, and with no original defects.

In ordering instruments, all that is necessary is to write or telegraph to us the kind of instrument desired, and we will forward by Express (unless a different method be desired). In giving the address to where the articles are to be forwarded, be careful to give the County as well as the State, thus: Send "Combined Transit and Leveling Instrument," price —, and the following extras, —, —, by express, to

Wm. Andrews, Civil Engineer,

Linden,

Cass County,

Texas.

as in some States there are several Express stations of the same name.

As there are three Chicagos, three Cincinnati's, six Philadelphia's, etc., in the United States, and each of them in a different State, it is best to always do this, even if the articles are to be sent to a large city.

Terms of payment are uniformly cash, and any of the following methods can be adopted: Remitting to us a draft on any banker or broker in this or any eastern city; or a "post-office money order." The best method is, however, by the Express C. O. D. system (collect on delivery). That is, the party ordering, paying the amount of our bill to the Express Agent on receipt of the goods.

Although we have our own standard and approved patterns, if any change in the style of the instrument, graduations, or numbering of the degrees be desired, we can do it.

#### Trial of Instruments Before Actual Purchase.

We judge from numerous letters received by us since the knowledge that we have increased the power of the ordinary Telescope, has been made public, that a personal examination of the Telescope (and instrument) before making a final purchase, would be more satisfactory to parties who are but slightly acquainted with us and our reputation. We make to such the following proposition: On making known to us the kind of instrument they desire, we will forward it to their address by express; and we will direct the express agent on delivery of the instrument to collect the amount of our bill, but instead of forwarding to us immediately as is usual, he will hold the money on deposit for say four days, or until the purchaser shall have thoroughly tested the instrument in the field. The purchaser can take the instrument and give it an actual trial in the field (four days should be ample for this), and if not found as represented, strictly first-class in all parts, and perfectly satisfactory in every respect, he may return it to the express agent before the expiration of the four days, and receive the money paid in full and no sale. The express agent will then return the instrument to us at our expense. If, however, the instrument is not returned to the express agent within the four days, it will be presumed that it is perfectly satisfactory, and the agent will forward the money to us.

In sales of this sort, however, as in all other sales, our original warranty holds good—*i. e.*, that any time after purchase if any defect appears after reasonable use, we agree either to replace with a perfect instrument or to refund the purchase money.

#### How to Send Instruments For Repairs.

In sending instruments of our own, or any other makes, to us for repairs, it is only necessary to place them in their own boxes, fill the box with some elastic material, such as paper, rags, etc. Place this in a packing box at least an inch larger in its dimensions than the instrument box, and fill the space between the two with shavings, straw, hay, etc. Mark on the box simply Heller & Brightly, Mathematical Instrument Makers, Philadelphia, Penna. Send it to us by express, and get at the same time from the agent two receipts; keep one and forward the duplicate to us. Send by mail at the same time a letter to us giving the items as to what repairs are needed and the time when the instrument is again required; and place a duplicate of this letter in the box with the instrument. If the Express charges to Philadelphia are prepaid by the sender (which is optional), it will be so stated in the receipt before mentioned.

Our charge for repairs can be paid by the Express Agent (C. O. D.), on our returning the articles. Remember, however, always to send the spindle (or ball and socket, if it be a Surveyor's Compass) on which the instrument turns, as it cannot be adjusted without; and a socket must be improvised at additional cost to the owner, if it be not sent. If, when the instrument is not of our make, it is required to be tested for magnetic attraction, or defective graduation, the fact must be mentioned in the letter of advice to us.

If the distance be not too great, it would also be best to send us the tripod legs and head, as the legs are frequently loose in their cheeks, and the iron shoes at their ends shaky and points worn off.

When instruments are sent to us to be repaired, we will, if requested, test any steel tape or chain that may be forwarded with them without extra charge, and give their difference in length as compared with the true United States standard (see "straight line measurements"), and the state of the thermometer at the time of trial. If, however, any repairing or adjusting of the chains, etc., be required, there will be an extra charge.

We have been frequently asked, since we have increased the power of our Telescopes, whether we could not place our new Telescope on instruments made by other firms. We have heretofore uniformly refused, as our new Telescope is a distinguishing feature of our instruments as compared with others. We have, however, reconsidered our determination, and will alter any Telescope to our new one; but in cases of this sort we will engrave on the Telescope tube the name of our firm. In altering the Telescope, all that will be necessary in a majority of the cases will be to remove the old object glass and eye piece, insert new ones, and to change the place of the cross wires.

#### What It Costs to Send a Transit or Leveling Instrument From Philadelphia to Any Part of the United States or Canadas or Vice Versa.

Parties from a distance frequently write us, "I have an instrument that requires repairing; about how much will be the express charges to Philadelphia from this place?" In order to give such parties an approximate idea of the cost of transportation, we give the following table of charge upon fifty and twenty-five pounds of freight to Philadelphia from one or more cities in each State. An engineer's transit, such as is made by regular makers (our own is somewhat lighter), with tripod head and legs, packed for shipment in two strong packing boxes, these boxes filled in with some elastic material, such as paper, shavings, etc., will average fifty pounds; the tripod head and legs alone, also packed in strong box, etc., will average from twenty to twenty-five pounds; tripod head, with leveling screws, etc. (but without the wooden legs), will average six pounds. (See Table of Express Freight Charges.)

From the table given it will be seen that the cost of sending a transit in its box from any part of the United States or Canada is so moderate (being only in the neighborhood of \$1.30 from Kansas to New York or Philadelphia) that it is the best policy, if a valuable instrument receives any injury anywhere in the United States, to send it to those who have all the facilities for making the necessary repairs and adjustments. As to any extra delay incurred, we will state that seven days only are needed to bring a transit from San Francisco to Philadelphia, and that the most seriously injured instrument, as a general rule, can have all the necessary repairs and adjustments made in six days. As an offset to this, there is the surety of the repairing being properly done, and in many instances the low prices charged by parties having the facilities for quick work more than counterbalance the express charges.

**TABLE OF EXPRESS CHARGES FROM PHILADELPHIA TO ALL PARTS OF THE UNITED STATES, OR VICE VERSA.**

February 1, 1914.

STATES	CITIES	25 lbs.	50 lbs.	75 lbs.	STATES	CITIES	25 lbs.	50 lbs.	75 lbs.
Alabama.....	Montgomery...	\$0.99	\$1.77	\$2.56	New Jersey...	Trenton.....	\$0.30	\$0.40	\$0.50
Alaska.....	Nome.....	4.41	7.92		New Mexico...	Santa Fe.....	1.89	3.17	4.66
Arkansas.....	Little Rock.....	1.10	2.00	2.90	New York.....	New York.....	.37	.55	.72
California.....	San Francisco.....	2.72	5.25	7.77	"	Albany.....	.46	.72	.99
Colorado.....	Denver.....	1.54	2.87	4.21	"	Troy.....	.46	.72	.99
Connecticut.....	Hartford.....	.46	.72	.99	North Carolina	Wilmington.....	.67	1.15	1.62
Delaware.....	Wilmington.....	.30	.40	.50	North Dakota	Bismarck.....	1.40	2.60	3.80
District of Co-	Washington.....	.40	.60	.80	Ohio.....	Cleveland.....	.57	.85	1.32
lumbia.....	Tallahassee.....	1.02	1.85	2.67	Oklahoma.....	Guthrie.....	1.20	2.37	3.46
Florida.....	Savannah.....	.86	1.52	2.10	Oregon.....	Portland.....	2.61	5.02	7.42
Georgia.....	Boise City.....	2.30	4.40	6.50	Pennsylvania...	Harrisburg.....	.37	.55	.72
Idaho.....	Chicago.....	.72	1.25	1.77	"	Pittsburg.....	.50	.80	1.10
Illinois.....	Indianapolis.....	.72	1.25	1.77	"	Lancaster.....	.34	.47	.61
Indiana.....	Dubuque.....	.79	1.37	1.96	"	Reading.....	.30	.40	.50
Iowa.....	Leavenworth.....	.97	1.75	2.52	Rhode Island...	Providence.....	.50	.60	.80
Kansas.....	Louisville.....	.71	1.22	1.74	South Carolina	Charleston.....	.81	1.42	2.04
Kentucky.....	New Orleans.....	1.20	2.20	3.20	South Dakota...	Yankton.....	1.10	2.17	3.16
Louisiana.....	Augusta.....	.60	1.00	1.40	Tennessee.....	Memphis.....	.91	1.02	2.34
Maine.....	Baltimore.....	.34	.47	.61	"	Nashville.....	.81	1.42	2.04
Maryland.....	Boston.....	.50	.80	1.10	Texas.....	Galveston.....	1.47	2.75	4.02
Massachusetts...	Detroit.....	.67	1.15	1.62	"	San Antonio.....	1.61	3.02	4.44
Michigan.....	St. Paul.....	1.05	1.90	2.75	Utah.....	Salt Lake City...	2.06	3.92	5.79
Minnesota.....	Jackson.....	1.06	1.92	2.70	Vermont.....	Montpelier.....	.57	.95	1.32
Mississippi.....	St. Louis.....	.79	1.37	1.96	Virginia.....	Richmond.....	.46	.72	.99
Missouri.....	Helena.....	2.10	4.00	5.90	Washington.....	Olympia.....	2.56	4.92	7.29
Montana.....	Omaha.....	1.05	1.90	2.75	West Virginia...	Wheeling.....	.55	.90	1.25
Nebraska.....	Virginia City.....	2.52	4.85	7.17	Wisconsin.....	Milwaukee.....	.77	1.35	1.92
Nevada.....	Concord.....	.55	.90	1.25	Wyoming.....	Cheyenne.....	1.60	3.00	4.40
New Hampshire...									

**CLASSIFICATION.**

Surveyors' Instruments (except tripods) and engineering or other scientific instruments, N. O. S. (not otherwise specified) must be refused unless boxed or in their own cases. Boxed at first class rate. In their own cases (not boxed) three times first class rate. Effective Feb. 1, 1914.

**HOW TO MAKE ONE DOLLAR DO THE WORK OF THREE.**

Special Notice to Those Sending Transits, Levels, &c. of Any Make to Us for Repairs.

After placing Instrument in its own case, put it in the packing box in which it was first shipped. If this box is lost, put the case in any rough wooden box, and stuff paper or straw around between the two to keep them from striking too much (your grocer will give you a soap or starch box for this purpose if you have none.) Tack on addressed tag on the top of the box, and send to us, per express. The reason for placing in this rough outside box, is that if packed in this manner, the express company only charge *one rate*; if sent only in its own case (without the rough outside box), the express company would charge *three rates*, in other words, the shipment that would cost packed in a rough box, 80 cents freight, would cost \$2.40 if sent only in its own case, although it would travel as safely one way as the other.

**Heller & Brightly's Steel Tape Measure (Standard).**

These Tapes can be graduated by us in any manner that may be desired. For bridge building, or city work, we generally make them 300 feet long. The first 290 feet graduated and numbered at every 10 feet distance; the next 9 feet at every foot, and the last foot into 10ths, or even closer if preferred. For Mine or Railroad work they are generally desired either 400 (a 400 foot Tape weighs without handles 2¼ pounds), or 500 feet in length, and graduated in a similar way to the above. We also furnish, if wanted, a "Clamping Handle," that can be attached to any portion of its length, in order that any measure shorter than the whole length can be taken without unwinding the entire length from the reel. (See account of a new measuring apparatus for straight lines, page 30.)

Steel Tape (of any length that may be desired, from 100 to 1,000 feet), with no joint from end to end. Lengths and graduations of precise U. S. standard (guaranteed).

First 100 feet..... \$6.00  
 Every extra 100 feet..... 5.50

At the above price every 50 feet is marked and figured, but no reel nor handles are furnished.

**EXTRAS.**

Every extra graduation and figuring, each..... \$ .20  
 Large brass handles to unship, each..... 1.50  
 Reel, with handle and stop (to wind up Tape)..... 3.50  
 Spring Balance, to use with above..... .50  
 Clamping Handle..... 1.80  
 Small Sleeve of brass. This sleeve is tinned inside, in which the ends of the tape when broken are slipped, and then soldered fast by merely heating the ends of the sleeve with a hot poker..... .10  
 Small brass clamp (to fasten on tape to mark any point which is to be used several times)..... .75

The cost of a 100 foot Tape, graduated and figured up to 90 feet at every 10 feet, the next 9 feet at every foot, and the last foot into 10ths, would be (without reel or balance):

Tape (graduated at every 50 feet)..... \$6.00  
 24 extra graduations and figuring the same, at 20 cents each..... 4.80  
 Pair of brass handles (to unship)..... 3.00

**\$13.80**



**Chesterman's Steel Tape Measures.**

These steel Tapes we always test with the true United States standard, and give the purchaser a note of the comparison and the state of the thermometer at the time of testing. (See straight line measurements.)

Steel Tape Measures; all steel, to wind up in a box, same as linen measures.

Steel Tape Measure, 10 feet long, in 10ths or 12ths, in German Silver case, each	\$3.25
Steel Tape Measure, 10 feet long, tape divided on one side to 12ths, and on the other to centimeters and millimeters	3.50
Steel Tape Measure, 25 feet long, in 10ths or 12ths, each	4.50
" " 33 " " " "	5.20
" " 40 " " " "	6.50
" " 50 " " " "	7.00
" " 66 " " " "	9.00
" " 75 " " " "	10.40
" " 100 " " " "	12.80
Steel Tape Measure, 3 feet long, in German Silver case, with spring and stop, tape divided into 10ths or 12ths of a foot	1.25
Steel Tape Measure, 4 feet long, in German Silver case, with spring and stop, tape divided into 10ths or 12ths of a foot	1.50
Steel Tape Measure, 5 feet long, in German Silver case, with spring and stop, tape divided into 10ths or 12ths of a foot	1.60
Steel Tape Measure, 6 feet long, in German Silver case, with spring and stop, tape divided into 10ths or 12ths of a foot	1.75
Steel Tape Measure, 3 feet long, tape divided on one side to 12ths of a foot, and the other side to centimeters and millimeters	1.25
Steel Tape Measure, 4 feet long, tape divided on one side to 12ths of a foot, and the other side to centimeters and millimeters	1.50
Steel Tape Measure, 5 feet long, tape divided on one side to 12ths of a foot, and the other side to centimeters and millimeters	1.60
Steel Tape Measure, 6 feet long, tape divided on one side to 12ths of a foot, and the other side to centimeters and millimeters	1.75

**Chesterman's Metallic Tape Measure.**

Metallic Tape Measure, 25 feet long, in 10ths or 12ths, each	\$1.85
" " 33 " " " "	2.10
" " 50 " " " "	2.60
" " 66 " " " "	3.00
" " 75 " " " "	3.30
" " 100 " " " "	4.20

**Swiss Drawing Instruments.**

Being frequently called upon to furnish the entire field and office outfit for Railroads and Civil Engineers, we here insert the prices of some strictly first-class German Silver instruments, and of office stationery. The drawing instruments are somewhat higher in price than the common sort, but are such as we furnish when the quality is left to our judgment. They are examined by us before forwarding, to see that the steel points are properly hardened and tempered, that the joints work equally, the drawing pens properly rounded and sharpened. We can, however, furnish, at catalogue prices, those of any firm that may be desired.

Plain Dividers, 4 1/2 inches long, each	\$1.50
Plain Dividers, 5 inches long, each	1.75
Plain Dividers, 6 inches long, each	2.50

Hair Spring Dividers, 4 1/2 inches long, each	\$2.25
Hair Spring Dividers, 5 to 6 inches long, each	2.50
Dividers, 6 1/2 inches long, with Pen, Pencil, Needle Points and Lengthening Bar	6.50
Dividers, 6 1/2 inches long, with fixed Needle Point and Loose Pen, and Pen Points and Lengthening Bar	6.00
Dividers, 6 1/2 inches long, joints in each leg, with Pen, Pencil, Needle Points, Dotting Pen and Lengthening Bar	9.00
Dividers, 4 inches long, with Pen, Pencil and Needle Points	5.00
Dividers, 4 inches long, with fixed Needle Point, and Pen and Pencil Points, changeable	4.50
Dividers, 4 inches long, with two fixed Needle Points	3.00
Dividers, 4 inches long, with fixed Needle Point and Pen Point	3.00
Dividers, 4 inches long, with Spring and Set Screw, Needle Point, Pencil Point and two Pen Points	7.00
Proportional Dividers, 6 1/2 inches long, finely graduated for lines	8.00
Proportional Dividers, 6 1/2 inches long, finely graduated for lines and polygons	9.00
Proportional Dividers, 9 inches long, finely graduated for lines and polygons	10.00
Proportional Dividers, 9 inches long, with micrometer adjustment, finely graduated for lines and polygons	12.00
Proportional Dividers, 8 inches long, with rack adjustment, graduated for lines	10.50
Bisecting Dividers, 7 1/2 inches long, each	4.25
Pocket Dividers, 5 to 6 inches long, with sheath, each	2.40
Three-Legged Dividers, 5 to 6 inches long, each	4.25
Steel Spacing Dividers, 5 inches long, with Ivory Handle	2.50
" " 3 1/2 " with Ivory or Metal Handle	1.50
" " 3 1/2 " with Ivory Handle and Needle Points	2.50
Beam Compass, 20 inches long, in 2 bars, with Pen, Pencil and two Straight Points	9.25
Beam Compass, 21 inches long, in 3 bars	10.50
" " 36 " 4 "	15.00
" " 54 " 4 "	21.00
Furniture for Wood Bar Beam Compasses, in morocco box	7.00
Boxwood Bar, 24 inches long, divided	6.75
Pillar Compasses, or Pocket Set of Instruments, with Points to change	2.50
Pillar Compasses, or Pocket Set of Instruments, with Points to change and Handles to Bow Pen and Pencil	7.50
Pillar Compasses, or Pocket Set of Instruments, with Points to turn	8.00
Spring Bow Pen, all steel, Ivory Handle	7.50
" " with Needle Point, all steel, Ivory Handle	2.00
" " German Silver	2.40
" " " with Pencil Point	2.00
All Steel Spring, Bow Pencil, Ivory Handle	3.00
" " " Needle Point	2.00
Drawing Pen, 4 1/2 inches long, with joints	2.40
" " 5 1/2 inches long, with joints	1.25
" " 6 1/2 inches long, with joints	1.40
Load or Double Drawing Pen	1.60
" " with joint in each side	3.75
Dotting Pen, with one wheel	3.00
" " with six wheels	2.00
Horn Centre, with German Silver edges	3.50
German Silver Centre, with handle	40
German Silver Fastening Tacks, per dozen	60
Steel Fastening Tacks, per dozen	60
Regular Curves of Horn, each	75
	75







1938

*Introducing*

**HELLER & BRIGHTLY, INC.**

LATEST MODEL  
ENGINEER'S TRANSIT

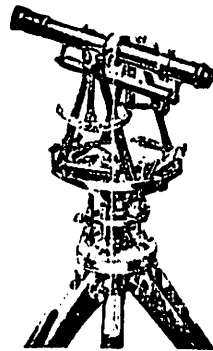

ESTABLISHED 1870

**HELLER & BRIGHTLY, Inc.**

████████████████████  
████████████████████  
N. W. Cor. Columbia Ave. and Hancock St.  
PHILADELPHIA, PA.

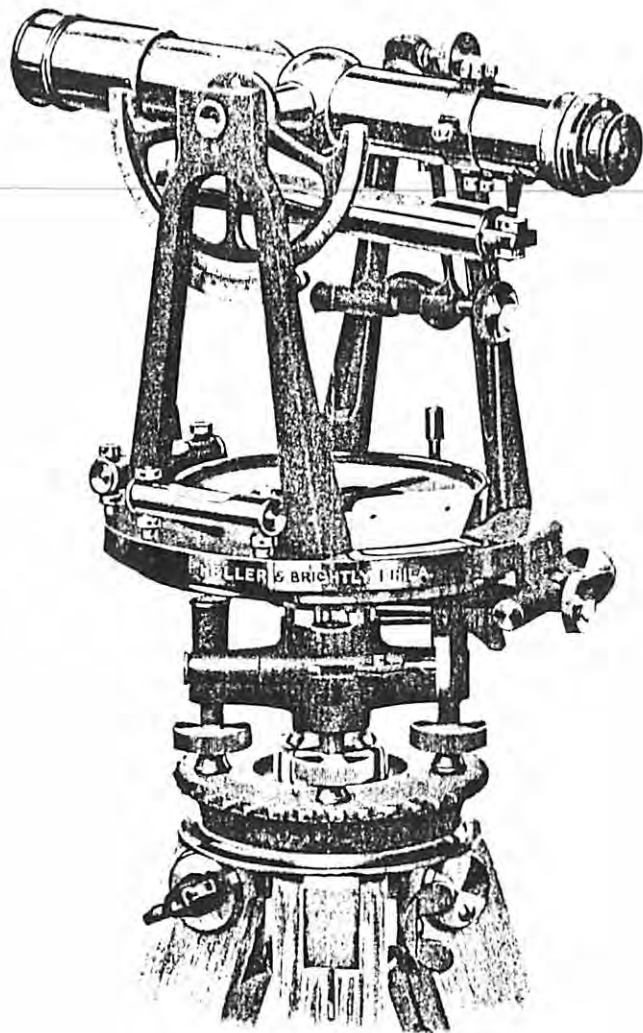

MODEL NO. 4B  
6¼ in. at Edge of Graduation

Telescope 11½ inches, erecting eye-piece, 1¼-inch objective, magnifying from 25 to 30 diameters. Telescope balanced in its axis, reversing at eye and object ends. Eye-piece has an improved threaded sleeve for quick focusing cross wires, all covered, dust proof, consequently no gumming or sticking. Slide for closing aperture in eye-cap when not in use. The lens combination gives a full flat field so necessary for satisfactory stadia work. Dust guard to objective slide. Line of collimation correct for all distances.

**Horizontal Limb** 6¼ inches in diameter at reading edge, being graduated upon solid silver to half degrees, opposite double verniers reading to single minutes, and numbered in two rows 0 to 360 each way, with figures inclined in the direction of their reading. Vernier openings 30° from line of sight allow the maximum of light, protected by white French plate glass covers which are easy to keep free from dust and moisture.

**Arrow head magnetic needle** 4¼ inches. Full or half **Vertical Circle** 4½ inches in diameter, graduated on solid silver to half degrees, vernier reading to one minute. Full circle protected by adjustment

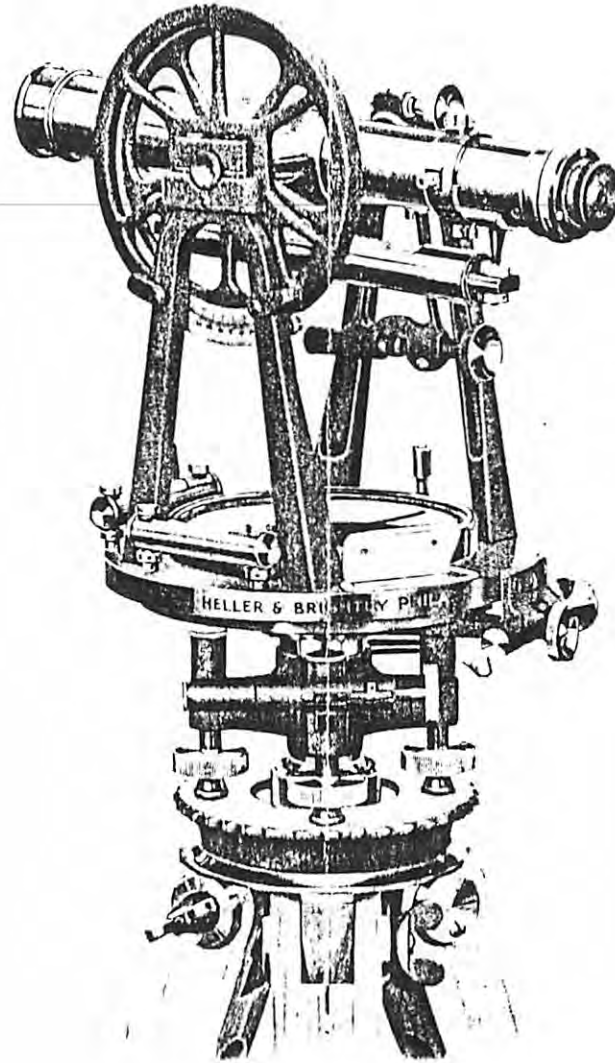

MODEL NO. 4C  
6¼ in. at Reading Edge

Long compound centers to plates, bronze against bell metal. Shifting center to leveling head for precisely centering over and under a point after approximately setting up tripod legs.

Leveling head is a single casting of improved form, so that the strains exerted by the four leveling screws will not bind the outer center in its socket. Leveling screws have rain and dust guards with a spun cup over bottom to prevent marring of tripod cap, when leveling screws are clamped.

Tripod legs of straight ash, full length, rigid, with tight steel shoes and aluminum protection cap to threaded head.

Telescope, plates, etc., polished, finished a dark bronze color, heavily bequered.

Standards, clamps, etc., morocco finish.

Weight of Plain Transit No. 4	.....	About 15	lbs.
Weight of Transit with Level Attachment No. 4A	.....	About 15 ½	lbs.
Weight of Complete Transit Nos. 4B and 4C	.....	About 16	lbs.
Weight of Tripod	.....	About 9	lbs.
Gross Weight of Instrument Complete, Packed in Two Boxes	.....	About 60	lbs.

Prices and extras to instruments on following page.

## PRICE LIST

Transit No. 4, Plain, with Clamp and Tangent to Telescope . . .	\$310.00
Transit No. 4A with Long 7-inch Sensitive Level, Clamp and Tangent to Telescope . . .	330.00
Transit No. 4B with Half 180° Vertical Circle . . . . .	355.00
Transit No. 4C with Full 360° Vertical Circle and Guard . . .	365.00

The above prices include, Stadia Hairs Fixed, Ratio, 1:100,  
Carrying Case, Split Leg Tripod and the usual accessories.

### Extras to the above instruments

Variation Plate for Magnetic Variation . . . . .	\$10.00
Extension Tripod . . . . .	5.00

(Price of additional extras on request)

---

---

### ENGINEERING                      SURVEYING                      MINING INSTRUMENTS REPAIRED

We as manufacturers, have the necessary equipment and facilities for making repairs to all makes of instruments, no matter what their condition. We can also supply any broken or missing parts.

As our workmen are all experts in this line, we can turn out work of the highest quality, promptly and at reasonable prices.

All work guaranteed.

We prepay return express charges on all instruments repaired at our factory.

Instruments shipped should be plainly marked and addressed to  
Heller & Brightly, Inc., 1124-26 Spring Garden Street, Phila., Pa.

Shipping tags for your convenience mailed upon request.

Place on file for future reference.