

DESCRIPTIVE PRICE-LIST

OF

FIRST-CLASS

Engineering & Astronomical Instruments

MANUFACTURED BY

GEORGE N. SAEGMULLER.

SUCCESSOR TO FAUTH & CO.

Second Street and Maryland Avenue S.W.

WASHINGTON, D. C.

This List Supersedes all former editions.

WASHINGTON, D. C. :
GIBSON BROS., PRINTERS AND BOOKBINDERS.
1901.

ANSWERS TO CORRESPONDENTS.

This Catalogue and price-list supersedes all former editions. The prices in this Catalogue are net cash.

We do not sell instruments on the installment plan.

We do not exchange instruments, nor do we keep second-hand instruments on hand.

Packing boxes are charged at cost price.

While we take the greatest care in packing, our responsibility ceases when instruments leave the factory. In case of damage, the express companies must be held liable.

Parties ordering goods to be sent C. O. D. must accompany their order with a deposit sufficient to pay expressage both ways.

C. O. D. packages will be sent with the privilege of examination, but we do not send instruments out on trial.

While the engravings in this Catalogue give a good idea of the instruments as we make them now, it must be borne in mind that our constant aim is to improve them by making them more accurate and simple, and unless it is especially requested we will always send the improved instruments.

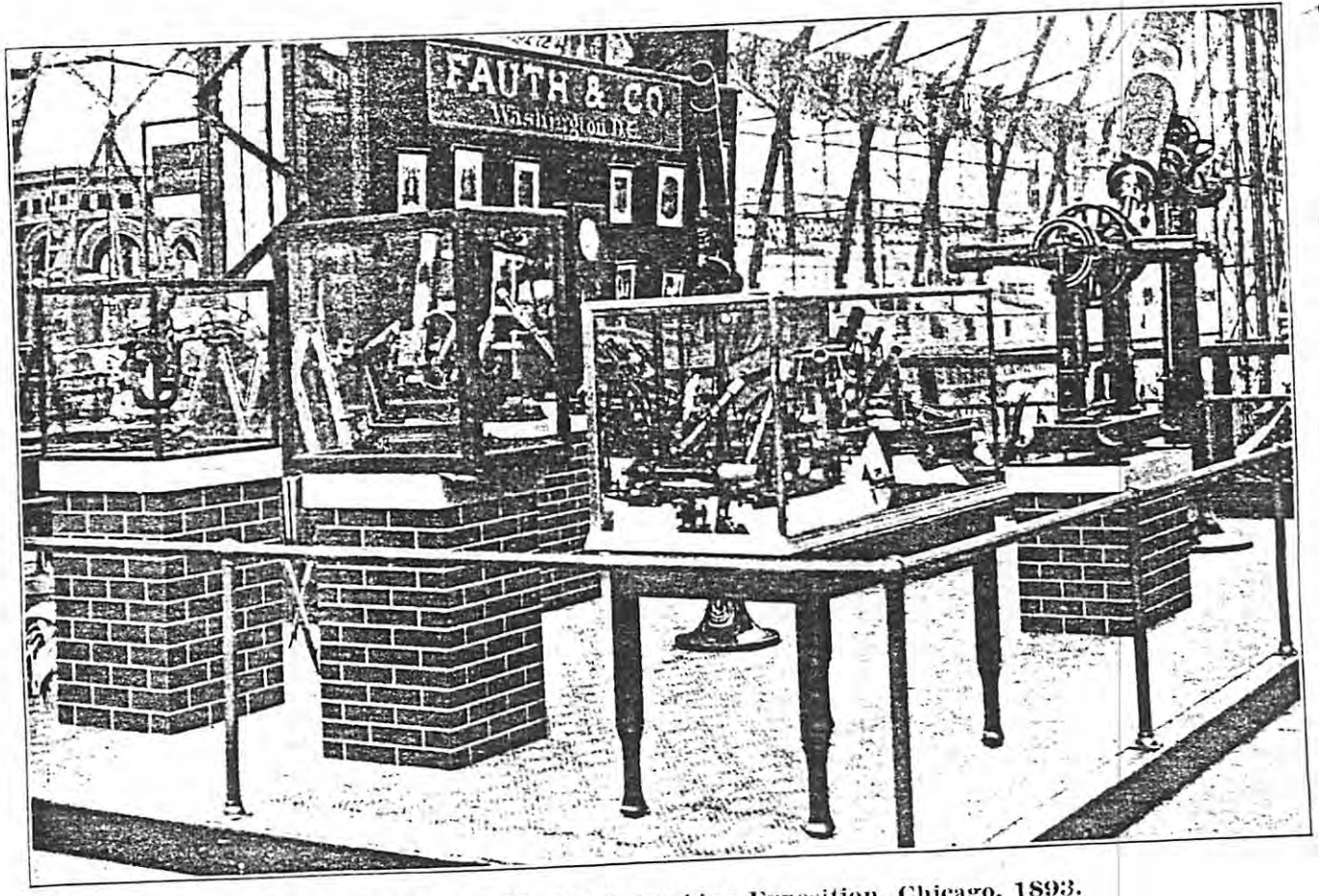

Our Exhibit at the World's Columbian Exposition, Chicago, 1893.



INTRODUCTION.

In presenting this Catalogue we call attention to the fact that nearly every instrument has been reconstructed to meet the increased requirements which progress in the sciences and engineering has made necessary. This is especially true of our engineering instruments, which we flatter ourselves cannot be excelled.

The nature of the work requires a light instrument having great optical power, accurate graduation that can be easily read, and the compass and verniers so protected as to be practically dust and water-tight.

We have, therefore, increased the power of the telescope and placed the verniers under it and at an angle of about 30° from it, thus allowing them to be read after sighting without changing position. Furthermore, the graduation is placed at an angle instead of being flat, which secures more light and greater convenience, as the head of the observer is further removed from the instrument while reading. By placing the plate levels inside the compass-box they are better protected and remain better in adjustment, although adjustable from the outside. The great disadvantage of having one of the verniers overshadowed by the plate level is thus avoided.

New Coast and Geodetic Survey Instruments.

As is well known, the United States Coast and Geodetic Survey has always aimed at the highest possible degree of accuracy in its work. To attain that end its officers have spared neither effort nor expense, especially as concerns instruments of precision. These efforts and expenditures have resulted in the designing of various types of greatly improved instruments, among which may be mentioned the Pendulum Apparatus, the Iced-Bar Base Apparatus, the Level of Precision, the new Tide Gauge, and others. Illustrations of these instruments will be found in the body of this Catalogue. Through the courtesy of the Superintendent of the Survey, who favored us with the loan of the necessary sketches and patterns, we are able to meet the demand that has been made upon us to construct instruments on these plans. We have already furnished an Iced-Bar Apparatus to Japan, and a number of Tide Gauges, Theodolites and Transits to the United States Navy. We are now engaged on a Pendulum Apparatus for the Dominion of Canada.

Having received numerous inquiries concerning the cost of standardizing Base Bars and Tapes, we have obtained from the office of Standard Weights and Measures a schedule of the fees charged by that office for comparisons, which will be found on page 32.

We have endeavored to make this Catalogue as brief and simple as possible, and we hope it may be found very much more convenient than some that are published, in which the desire to make a big book has been so fully gratified as to render it exceedingly difficult to find what one is searching for in them.

GEORGE N. SÆGMULLER.



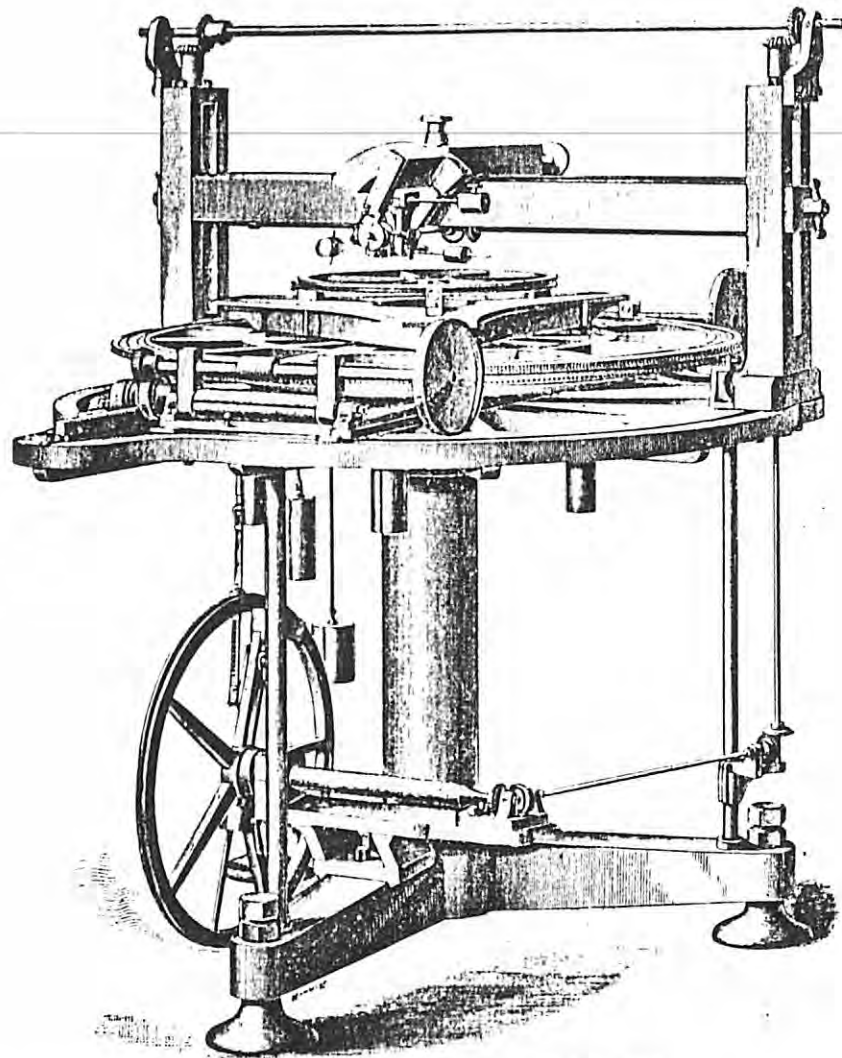

Large Automatic Dividing Engine.

For the performance of this engine see the following pages and Dr. Porter's letter on page 80.

GRADUATIONS.

The cut on preceding page represents our large Dividing Engine, which we venture to say is one of the best engines ever constructed. We do not claim that it is perfect and we do not believe that a really perfect circle has ever been made. We have often heard the statement that this or that machine graduates with no error greater than one second. Such statements are ridiculous, and we think we have reached the possibilities when we can make an automatic graduation correct to within 2 or 3 seconds of arc. That we have reached this result will be seen by the following:

DEPARTMENT OF THE INTERIOR,
UNITED STATES GEOLOGICAL SURVEY, GEOGRAPHIC BRANCH,
WASHINGTON, D. C., *January 18, 1892.*

Mr. G. N. SAEGMULLER,
108 2d Street S. W., *City.*

MY DEAR SIR: In response to your request of recent date, I take pleasure in sending you herewith a copy of the record of certain examinations of theodolites made by you for this office.

Concerning 8-inch theodolites, Nos. 300, 362, and 438, the results of the examination of the graduations are given in full.

Concerning six of the seven theodolites which you made for us, I send you an abstract showing for each instrument the greatest plus and the greatest minus errors of subdivision.

Sincerely yours,

HENRY GANNETT,
Chief Topographer.

8-inch Theodolite No. 300.

Trial Standard Space 2° 30' 2° 40'				Error of Space Divs.	Trial Standard Space 2° 30' 12° 40'				Error of Space Divs.
2°	30'	2°	40'		182°	30'	12°	40'	
12°	30'	12°	40'	192					
22				202					
32				212					
42				222					
52				232					
62				242					
72				252					
82				262					
92				272					
102				282					
112				292					
122				302					
132				312					
142				322					
152				332					
162				342					
172				352					

8-inch Fauth & Co. Theodolite.
No. 438. No. 362.

Standard Space 6" to 6" 10'		Error of Space Div.	Standard Space 359' 50" - 360' 00"		Error of Space Div.
6" 00'	6" 10'	-.10	359' 50"	360' 00"	-.02
16	16 10	-.08	9 50	10	-.03
26	26 10	-.90	19 50	20	+.11
36	36 10	+.34	29 50	30	-.07
46	46 10	-.02	39 50	40	+.13
56	56 10	+.08	49 50	50	+.15
66	66 10	-.80	59 50	60	-.39
76	76 10	+.08	69 50	70	-.11
86	86 10	-.10	79 50	80	+.27
96	96 10	-.46	89 50	90	+.03
106	106 10	-.98	99 50	100	+.03
116	116 10	-.08	109 50	110	+.03
126	126 10	+.14	119 50	120	-.37
136	136 10	-.12	129 50	130	-.45
146	146 10	-.52	139 50	140	+.03
156	156 10	-.52	149 50	150	-.27
166	166 10	-.64	159 50	160	+.31
176	176 10	-.50	169 50	170	+.33
186	186 10	-.70	179 50	180	-.17
196	196 10	-1.24	189 50	190	-.45
206	206 10	-0.82	199 50	200	+.55
216	216 10	-.46	209 50	210	-.33
226	226 10	-.72	219 50	220	+.23
236	236 10	-.52	229 50	230	+.13
246	246 10	-.50	239 50	240	+.23
256	256 10	0.50	249 50	250	-.27
266	266 10	-0.24	259 50	260	+.05
276	276 10	+0.60	269 50	270	-.19
286	286 10	+.08	279 50	280	+.23
296	296 10	-.72	289 50	290	-.29
306	306 10	+.14	299 50	300	-.01
316	316 10	-.60	309 50	310	+.47
326	326 10	+.08	319 50	320	+.07
336	336 10	-.38	329 50	330	-.05
346	346 10	-.38	339 50	340	+.17
356	356 10	-.36	349 50	350	-.07

8-inch Fauth & Co. Theodolites.
Summary of Space Errors.

	ERROR OF 10' SPACE.	
	Largest.	Smallest.
8" Theod. No. 300.....	+1" .58	-1" .26
362.....	+0 .55	-0 .45
434.....	+0 .62	-0 .76
435.....	+0 .69	-0 .59
436.....	+1 .17	-0 .89
438.....	+0 .60	-1 .24

The wonder is that machines attaining such a degree of accuracy can be made, and not that they are not any more perfect. A second of arc appears large on paper, but in fact is scarcely perceptible in a microscope.

For nearly all practical purposes such extreme accuracy in graduations is not at all required. Whether the instrument is used as a repeater or by shifting position, it is clear that the small errors in the graduations will entirely disappear in the final result.

But for such circles as are used on Meridian instruments we are not satisfied with the degree of precision that our automatic machine gives. Recourse must be had to corrections, and this we accomplish by using the machine automatically only for small arcs, having previously divided the circle into larger spaces, which can quickly be done by copying before changes in temperature have effected a change in the relation of the engine and the circle which is to be divided. By this process we obtain graduations—each line correct to within one second of arc.*

Our engine is made entirely of cast iron and steel, the moving parts being hardened steel, and a novel arrangement has been introduced for turning two opposite screws, which insures a perfect equality in their motions. As stated before, the errors in automatically divided circles are between 2 and 3 seconds.

Of course so small an error is not perceptible in any vernier reading instrument. The graduations of the latter may be considered perfect.

A silver surface is the most satisfactory for a good Graduation. We use it exclusively for the better class of instruments. The circles for our larger instruments are divided into 2-minute or 5-minute spaces; these are read to single seconds by means of micrometer-microscopes, which are now being extensively used with circles of small radius. To attempt to read a fine graduation by means of a vernier to single seconds, even on a moderately large circle, is very trying to the eye, besides involving two operations at the same time—the seeking for the coincidence and the counting from the zero. With a reading-microscope these two operations are separate—first, a bisection is made by turning the micrometer-screw, and then the divided head is read off as the second part of the operation. It is as easy to read to single seconds by means of micrometer-microscopes as it is to read minutes by means of the vernier. The vernier, however, is so simple, and the accuracy with which readings can be taken is so surprisingly great, that it will always hold its place for circles of smaller radius.

Our engineers' transits are graduated either into $\frac{1}{2}$ degrees, reading to single minutes by the vernier having 20 circle parts divided into 30; or the circle is graduated into $\frac{1}{4}$ -degree spaces, reading to half minutes by the vernier having 39 circle parts divided into 40. Or the circle is graduated into $\frac{1}{4}$ -degrees and

* See letter of Dr. Porter; on page 80, in regard to the accuracy of the Meridian Circle we graduated for him 10 years ago in the manner indicated above.

the vernier reading to 20 seconds by having 44 circle parts divided into 45. Or the circle is divided into 1 degree and the vernier reading to 10 seconds by having 59 parts divided into 60.

We take it for granted that any one likely to read this pamphlet knows how to read a vernier.

In order to eliminate any eccentricity of limb or vernier-plate, there should be two verniers 180 degrees apart, as the mean of both readings will completely correct it.

The verniers should always have reflecting shades attached to them, as they throw an even light on the graduation; and it is also of great importance that graduations reading 20" and less should have the reading-glasses permanently attached in such a manner that they can be moved radially along the entire length of vernier.

THE MICROMETER-MICROSCOPE.

We are often asked to explain the reading-microscope by parties who have never used them; we think the following description will make its construction and use quite plain:

This instrument consists of a microscope having a set of movable threads in the focal plane of the object-glass. The threads are attached to a diaphragm, which is moved parallel to itself in the micrometer box or frame by a screw of small pitch. The revolutions of this screw and consequent motion of the threads are counted by means of a notched or comb scale, which corresponds exactly to the pitch of the screw and is visible through the eye-piece along with the threads. The parts of a revolution are counted by means of a drum or micrometer head, divided into equal parts, attached to and turning with the screw.

The objective of the microscope gives an inverted image in the plane of the cross-threads of any object viewed through the microscope. The eye-piece shows this image and the cross-threads without further inversion; that is, the eye-piece shows an inverted image of the object and an erect image of the cross-threads and comb scale.

Where the micrometer-microscope is used to read circles it is convenient to have the pitch of the screw and the focal distances of the objective so related that an even number of turns of the screw will correspond to the smallest space on the circle. Thus, if the circle is divided into 10' spaces it is convenient to have one such space equivalent to five or ten revolutions of the screw; so that one revolution will be equivalent to 2' or 1' as the case may be. Similarly, the micrometer head may be divided to suit our convenience. If, for example, one revolution is equivalent to 1', the micrometer head may be divided into sixty equal parts, giving thus 1" per division. If, on the other hand, one revolution is equivalent to 2', the heads of the micrometers (if there are two of them)

should be divided into sixty equal parts and numbered from 0 to 30 twice. The reason for this is that in general the mean of the two microscope readings is desired; and since in this relation the value of one division is 2", the mean value sought, *in seconds*, is simply the sum of the two micrometer-head readings.

Adjustments.—The following adjustments are to be observed with the micrometer-microscope:

1. To secure distinct vision of the cross-threads, the eye-piece must be moved out or in until the threads are clearly and sharply defined. This adjustment is independent of all others; it differs for different persons, and is the first one to be attended to in using the microscope.

2. To make an even number of turns of the screw equivalent to a given space, measure the image of the space with the screw. If the image is too small the objective must be brought nearer to the object and the cross-threads moved further from the objective; and opposite motions of the parts must be made if the image is too large. The tubes carrying the objective and micrometer box permit such motions. A few trials will make this adjustment sufficiently close.

In making this adjustment care must be taken to avoid parallax, which occurs when the cross-threads and image of the object viewed are not in the same plane. It is detected by moving the eye to and fro sidewise while looking through the eye-piece. If the threads and image show any relative motion there is parallax. It may be removed (supposing the first adjustment made) by moving the whole microscope nearer to or further from the object.

3. To bring the zero of the comb scale into coincidence with the cross-threads when the micrometer head reads zero, move the comb scale by means of the adjusting screw at the end of the micrometer box. This adjustment need not be very close, since the only office of the scale is to count whole revolutions. It may be also accomplished by moving the micrometer head on the screw shaft, since the head is usually held fast by means of a lock nut on the shaft.

4. To place two opposite microscopes 180° apart closely, set one of them at zero and bring a graduation line to bisect the thread interval. Then the other microscope

may be brought to bisection on the opposite line, and by moving the drum on the screw shaft and adjusting the comb scale to suit, it may be made to read within a few divisions of the first micro-

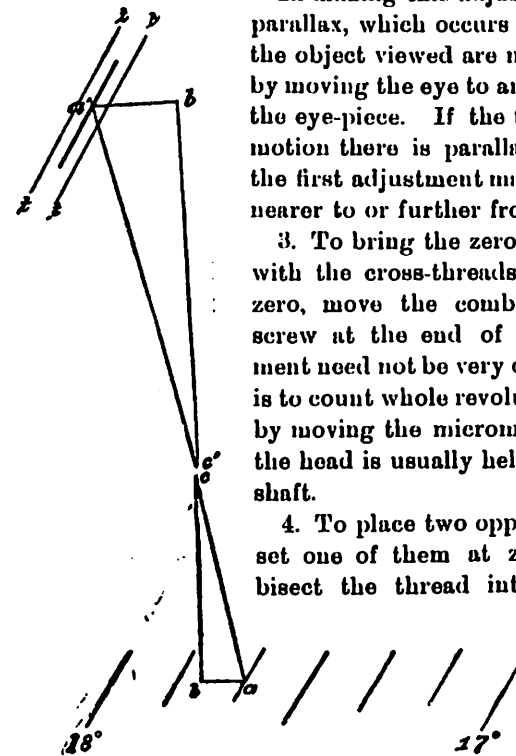

No. 2.

scope. Close agreement is not essential, but it is convenient to have both microscopes read the same to the nearest minute.

Method of reading Micrometer-Microscopes.—This may be best understood, by considering a special case. Thus, suppose it is required to read the two opposite micrometer-microscopes of a theodolite whose circle is divided into 10' spaces. Let five revolutions of the screw be equivalent to one of these spaces. Then one revolution is equivalent to 2', and the micrometer heads will be assumed to be divided into sixty equal parts and numbered from 0 to 30 twice. The relations to be considered are illustrated in the diagram on page 11, which shows a degree of the circle, the positions of the principal points of the microscope objective, the position of the micrometer threads, tt , etc. In this diagram the line $bc, b'c'$ is the line defined by the micrometer threads (or the point midway between them) when the micrometer reads zero revolutions and zero divisions. This line falls between the 40' and 50' lines of the circle, and the reading of the circle is $17^{\circ} 40'$ plus the distance ab expressed in angular measure. But the image and equivalent of ab is $a'b'$, and this is measured by moving the micrometer threads until the space between them is bisected by the image of the 40' line a , or by a' . Suppose the distance $a'b'$ is three revolutions (counted by three notches of the comb scale) and 8.3 divisions of the head. Then the complete reading is $17^{\circ} 46' 16''.6$.

If the opposite micrometer reads $197^{\circ} 46' 11''.9$ divisions, the mean reading of the circle is (using the degrees from the first microscope) $17^{\circ} 46' 20''.2$ since $\frac{1}{2}(8.3 + 11.9) 2'' = 20''.2$.

It should be observed that the micrometer-head readings properly increase as the screw is turned backwards, but in bringing the threads to bisection the screw should always be turned positively, or so as to pull the diaphragm against the springs which hold the micrometer screw in its bearings.

TELESCOPES.

While we do not attempt to give the theory of the Telescope, which is found in every book on optics, we add a few remarks concerning objectives and different kinds of eye-pieces.

It is well known that a good objective consists of at least two lenses, one of them being of crown, the other of flint glass. By this combination of glasses, which have different refractive powers, it is possible to correct the chromatic and spherical aberration. The latter correction is best shown by the permanence of the focus, whether the image be formed by the centre or outer portion of the objective; and by partly covering the objective so as to use only certain portions it is easily found how nearly this error has been eliminated.

The achromatic correction of the glass is proved by the absence of the more brilliant colors of the spectrum. It is impossible, with any known combination of glasses, to perfectly overcome the chromatic aberration, as all the colors cannot be united in one point. There will always remain what is called the secondary spectrum.

A glass, however, is well corrected if, on focusing a bright object and then pushing the eye-piece nearer to the objective, a ring of purple surrounds the image, and a ring of green appears if the eye-piece is moved away from the objective.

Small scratches and bubbles in the objective have no injurious effect, as they only take up a very small portion of light. Veins and striae in a glass, however, are very injurious. They can readily be detected by viewing a bright object, like the moon, or a flame, without the eye-piece. If the glass is evenly illuminated it shows that there are no such veins and that it is homogeneous.

EYE-PIECES.

The performance of a good Telescope depends much more upon the eye-piece than is commonly supposed. And as it is as desirable for the manufacturer as it is for the purchaser that the latter should have easy means of ascertaining what kind of eye-piece will be most suitable, we give a plain description of the different kinds of eye-pieces most in use and the method of determining the power required.

And here we wish to remark that for all practical purposes we consider the Ramsden and Huyghen eye-piece equal to any. For very high powers the solid eye-pieces may be better on account of the absence of the "ghost," but the gain in achromatism and flatness of field in the various so-called achromatic combinations is so small that only an expert can detect it.

It frequently occurs that eye-pieces are ordered without considering the diameter of the adapter or draw-tube to which they have to be attached; and we are frequently compelled to cut down the diameter of the lenses, and consequently the field, much to our own dissatisfaction and that of our customers.

The word "equivalent," in connection with eye-pieces, simply means a comparison of the magnifying power of the compound eye-piece with that of a single lens of a certain focus; thus, a compound eye-piece which is mentioned as the equivalent of *one inch* magnifies as much as a single lens of *1-inch* focus, and, since the magnifying power of a telescope is found by dividing the focus of its object-glass by that of the eye-piece, it follows that, in order to find the "equivalent" of the eye-piece needed for obtaining a certain magnifying power, the focus of the object-glass has to be divided by the power required, the quotient being the "equivalent" of the eye-piece. Accordingly, if a power of 60 is required with an objective of 30 inches focus, an eye-piece of

$\frac{1}{2}$ -inch focus has to be used, since $\frac{30}{60} = \frac{1}{2}$.

The following cuts represent the lenses, their distances from each other and their diameters, of the "equivalent" of *one inch* of the different kinds of eye-pieces, from which higher or lower powers may readily be computed.

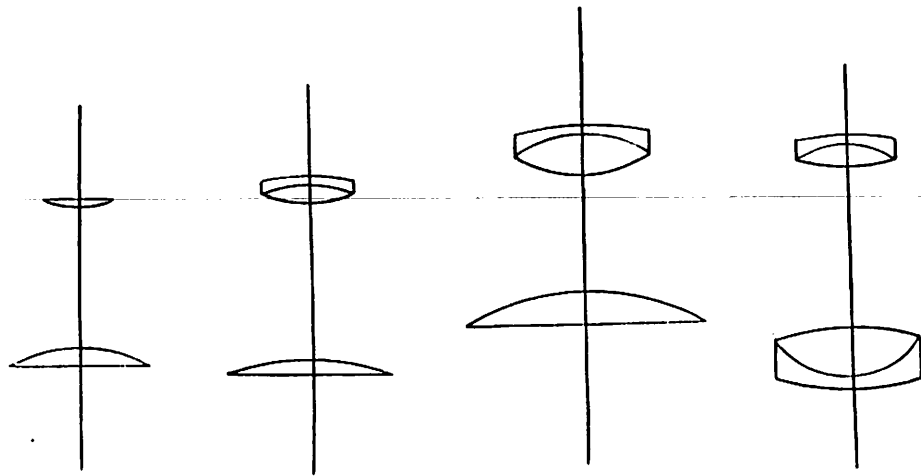

FIG. 1.

FIG. 2.

FIG. 3.

FIG. 4.

It should be kept in mind that for micrometer or cross-hair observations only positive eye-pieces are used, as the focus of the objective is formed in front of the combination; while in the negative eye-piece it falls between the two lenses.

Of positive eye-pieces we have three kinds: the "Ramsden" (Fig. 1), the "Kellner" (Figs. 2 and 3), and the "Steinheil" (Fig. 4). The "Kellner" and "Steinheil" are achromatic combinations, and preferable on account of the absence of color and the greater flatness of the field which they give.

The "Ramsden" has for a long time been the only compound positive eye-piece in use, and does good service. It consists of two plano-convex lenses of equal focus, the plane surfaces being turned outward; the focus of each lens is equal to $1\frac{1}{2}$ of the "equivalent" of the eye-piece, the distance between them being equal to $\frac{2}{3}$ the focus of either lens, and the aperture may be taken as $\frac{1}{2}$ the focal length of either lens.

The "Kellner" consists of a plano-convex, or sometimes a crossed field-lens and an achromatic eye-lens. We give two sketches of it (Figs. 2 and 3). Fig. 3 has the field-lens cut down to secure the greatest possible flatness of field; Fig. 2 is used in cases where the extremest angle of field is required.

The "Steinheil" (Fig. 4) consists of two achromatic lenses. It gives a beautiful field of moderate size, but absolute flatness.

Of negative eye-pieces we have two kinds, the "Huyghens" and the "Airy" (Figs. 5 and 6), the latter being an improvement of the former. They are both achromatic on account of their peculiar construction; the "Huyghens" giving a large but somewhat curved field, while the "Airy" has a perfectly flat and large field. The proportion of foci of eye-lens and field-lens is as 1 to 3, and the distance between the lenses is equal to $\frac{1}{2}$ of their compound foci. The diameter

of the field-lens is equal to the "equivalent" of the eye-piece. Thus, the field-lens of a 1-inch eye-piece has a diameter of 1 inch.

All the eye-pieces above mentioned show the objects inverted. As this seems

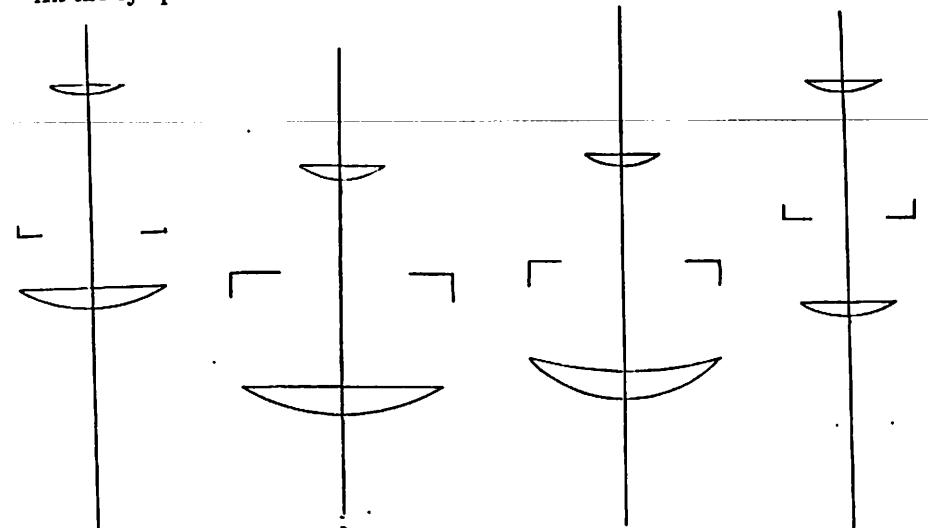

FIG. 5.

FIG. 6.

FIG. 7.

FIG. 8.

to be troublesome to the engineer, "erecting" or "terrestrial" eye-pieces are mostly used on engineering instruments.

As both light and power in the telescope are gained by using inverting eye-pieces, and as it only requires very little practice to get accustomed to them, we strongly recommend the use of inverting or astronomical eye-pieces.

So far, however, engineers seem to prefer Telescopes showing erect. To effect this, four lenses are required, arranged as shown above, and forming the "terrestrial" eye-piece. We make two kinds of these: the "Fraunhofer" (Fig. 7), and the "Airy" (Fig. 8). The latter is mostly used on our levels and transits, as it gives a very flat field and defines well.

The terrestrial eye-piece is often made with a total reflecting prism between the anterior and posterior combinations. They are then called "diagonal" or "elbow" eye-pieces, and are very convenient when observing near the zenith.

As before stated, the magnifying power of a Telescope is found by dividing the focal length of the objective by that of the eye-piece; but a more simple and

practical method is the following: Focus the Telescope to any distant object; then withdraw the eye to a distance at which a near object is distinctly seen, when a small disc of light will appear in the centre of the eye piece. This is the image of the objective. If measured by means of a finely-divided scale and divided into the diameter of the objective, the quotient will be the magnifying power. Thus, supposing a Telescope to have a clear aperture of 2 inches, the diameter of the image being $\frac{1}{32}$ of an inch, then the magnifying power of such a telescope would be 2 inches divided by $\frac{1}{32}$ = 32 diam.

By means of a dynameter this image can be measured very accurately, but the above-described method is good enough for all practical purposes.

The power of a Telescope can be increased by substituting an eye-piece of shorter focus; but this increase brings with it a corresponding loss in size and brightness of field. As a general rule it is better to use lower than higher powers.

In Telescopes for engineers' transits and levels, the aperture of the objective and the corresponding magnifying power are carefully determined. The least motion of the level-bubble must be visible by the displacement of the cross-wires. It is therefore important that the magnifying power of a telescope and the sensitiveness of a level are proportionate to each other.

Take the case of a Telescope for a precise level, for instance; one division of the graduated level-bubble equals five seconds of arc. Each division being 2mm., a displacement of one-tenth can readily be observed, which means that the instrument was raised or depressed just $\frac{1}{2}$ second of arc. The Telescope, in order to make this small change visible on the rod, must have a magnifying power of about 25 diameters, for it has been observed that the accuracy of pointing is nearly proportional to the magnifying power, unless the latter is out of all proportion to the aperture. As the naked eye can readily point with ordinary sights to within 10 to 15 seconds of arc, or say $12\frac{1}{2}$ seconds, it follows that, in order to point within $\frac{1}{2}$ second, we must have a power of $\frac{12\frac{1}{2}}{\frac{1}{2}} = 25$.

The lenses of a telescope should not be cleaned too often. Too frequent wipings will scratch the glass and injure the polish, which is more injurious than a little speck of dirt. When it becomes necessary to clean the glass, take a soft dry piece of chamois skin or old piece of linen which by repeated washing has become soft. If the glass is very dirty, use a little alcohol.

Dirt on the eye-piece, especially on the field-lens, is far more objectionable than on the objective; hence they require to be more frequently cleaned.

LEVELS.

The Spirit-Levels form a most important part of an instrument, and, no matter how small they are, they should always be ground to a regular curve. At one time Levels were made by merely filling tubes with alcohol and then hermetically

sealing them. By testing these tubes, one side of them was frequently found to be so nearly uniform in curvature as to form quite a good Level. The majority of Levels thus made are, however, very inferior. All the better Levels are now ground to a curve, and it is obvious that the greater the curve the more sensitive is the Level. The sensibility, as well as the uniform run of the bubble, is easily determined by the use of an instrument called the "Level Trier," which is a grooved bar of metal having two-foot screws at one end, and one carefully-made micrometer-screw with a divided head at the other end. Knowing the length of this bar and the pitch of the screw, it is easy to find the value "in arc" corresponding to one division of the divided head. By placing the Level to be tested on the grooved bar, the turning of the screw will show whether equal quantities of elevation will produce equal spaces of run in the bubble, and at the same time show how many inches on the scale are equal to one minute of arc. This value being known, the radius of the curve to which the interior face of the Level has been ground is easily determined. Let r denote the radius of the curve, 21,600 being the number of minutes contained in the circumference of a circle, d the distance in inches and parts run over by the bubble in one minute of elevation, and $2\pi = 6.2832$ being the measure of the circumference to the radius 1, then: $r = \frac{21600 d}{6.2832}$.

For instance, take a Level in which we find $d = 2$ inches, then the radius of curvature will be $\frac{21600 \times 2}{6.2832} = 6878.6$ inches = 573.2 feet.

It is to be observed, however, that owing to the adhesion and friction of the fluid the values of the curvature thus found are always a little smaller than they are in reality.

A first-class Level should not only have the curve regular, but it should be perfectly symmetrical—that is, one end of it should have the same width as the other.

If this is not the case, the length of the bubble, in changes of temperature, will change unequally at both ends.

We grind our Levels by a machine which not only shapes them to a perfect curve of any desired radius, but at the same time grinds the entire interior surface, thus making them perfectly symmetrical and not liable to any of the above-mentioned defects.

Sensitive Levels are frequently injured by not being properly fastened in their tubes; the common way of fastening them in with plaster of Paris is entirely inadmissible for any Level of accuracy, as glass and brass will not expand or contract alike. We have lately improved the method of mounting fine Levels by securing them in a Y placed in each end of the brass tube. By means of a spring just strong enough to insure a firm bearing the Level-tube is retained in position without undue strain. All our Sensitive Levels are provided with chambers for altering the length of the bubble; they are also covered with a glass tube, to guard against sudden changes of temperature.

THE SAEGMULLER PATENT SOLAR ATTACHMENT.

This attachment to the regular Engineer's Transit, by means of which the astronomical meridian may be obtained in a few minutes with an accuracy scarcely thought to be possible, has met with such success that it bids fair to supersede all other methods for the determination of the meridian by means of engineering instruments.

The transit has come to be the universal instrument for the engineer, and will be for the surveyor sooner or later, and the attachment of the solar apparatus to the transit has thus become a necessity.

Since its first introduction this attachment has been greatly improved, and, as now made, is well nigh perfect.

Attached to any transit which possesses a telescope, level and a vertical circle, it will give the meridian within the nearest minute. By using instruments which have a finer graduated vertical circle and better levels than are usually found on transits, the meridian can be determined with greater accuracy still.

Advantages of the "Saegmuller Solar Attachment" over the old form.

First. It is more accurate.

Second. It is simpler and easier of adjustment.

Third. It can be used when the sun is partly obscured by clouds, when the ordinary "solar" fails altogether.

Fourth. It can be used where the sun is quite close to the meridian.

Fifth. The time can be obtained with it reliable to within a few seconds with perfect ease.

Sixth. It can be used as a vertical sighting telescope.

It is as superior to all forms hitherto used as the transit is to the ordinary compass, or as a telescope is to common sights.

The sights of an ordinary solar compass consist merely of a small lens and a piece of silver with lines ruled on it placed in its focus. This is simply a *very primitive* telescope, since the exact coincidence of the sun's image with the lines has to be determined by the unaided eye, or at best with a simple magnifying glass.

That far greater precision can be attained by means of a suitable telescope is obvious; in fact, the *power* of the solar telescope is in keeping with the transit telescope, as it should be.

A glance at the cut will show that the "Saegmuller Solar Attachment" is far simpler than the ordinary form. By raising or depressing it can be set to north or south declination. To effect this with the ordinary solar compass *two* sets of *primitive telescopes*—one answering for north, the other for south declination—are required, which are difficult to adjust.

The addition of the level on the solar telescope dispenses with the declination arc altogether, the arc or circle on the transit also serving for that purpose in conjunction with it.

The "Saegmuller Solar Attachment" is in fact the only one which should be used in connection with a transit instrument. *It solves the solar problem*, as has been attested by leading astronomers and engineers who have used it.

Prof. J. B. Johnson, of Washington University, St. Louis, Mo., has given it a thorough test, and writes as follows:

"In order to determine just what accuracy was possible with a Saegmuller Solar Attachment, I spent two days making observations on a line whose azimuth had been determined by observations on two nights on Polaris at elongation, the instrument being reversed to eliminate errors of adjustment. Forty-five observations were made with the solar attachment on Oct. 24, 1885, from 9 to 10 A. M., and from 1.30 to 4 P. M., and on Nov. 7, forty-two observations between the same hours.

"On the first day's work the latitude used was that obtained by an observation on the sun at its meridian passage, being $38^{\circ} 39'$, and the mean azimuth was 20 seconds in error. On the second day, the instrument having been more carefully adjusted, the latitude used was $38^{\circ} 37'$, which was supposed to be about the true latitude of the point of observation, which was the corner of Park and Jefferson avenues in this city. It was afterwards found this latitude was $38^{\circ} 37' 15''$, as referred to Washington University Observatory, so that when the mean azimuth of the line was corrected for this $15''$ error in latitude it agreed exactly with the stellar azimuth of the line, which might have been $10''$ or $15''$ in error. On the first day all the readings were taken without a reading glass, there being four circle readings to each result. On the second day a glass was used.

"On the first day the maximum error was $\frac{1}{2}$ minutes, the average error was 0.8 minute, and the 'probable error of a single observation' was also 0.8 minute. On the second day the maximum error was 2.7 minutes, the average error was 1 minute, and the 'probable error of a single observation' was 0.86 minute. The time required for a single observation is from three to five minutes.

"I believe this accuracy is attainable in actual practice, as no greater care was taken in the adjustment or handling of the instrument than should be exercised in the field.

"The transit has come to be the universal instrument for the engineer, and should be for the surveyor, so it is more desirable to have the solar apparatus attached to the transit than to have a separate instrument. The principal advantages of this attachment are:

"1. Its simplicity.

"2. Its accuracy of pointing, being furnished with a telescope which is accurately set on the sun's disk.

"3. In its providing that all angles be set off on the vertical and horizontal limbs of the transit, thus eliminating the eccentricity and other inaccuracies usually found in attachment circles or arcs.

"4. Its small cost.

"It is also readily removed and replaced without affecting its adjustments, and is out of the way in handling and reversing the telescope. It may be attached to any transit."

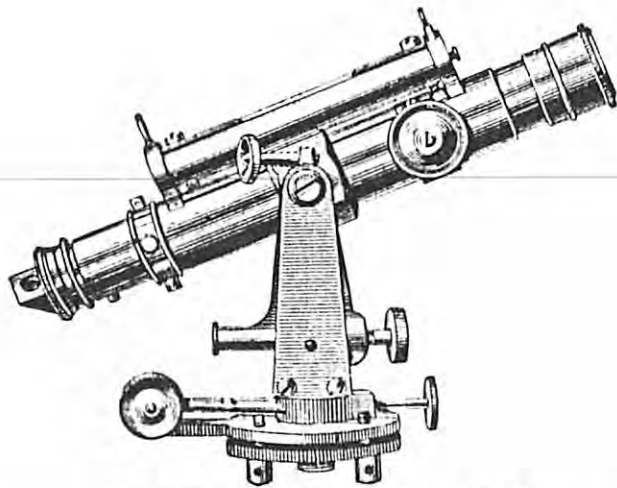

Saegmuller Solar Attachment.

The above cut represents the improved "Saegmuller Solar Attachment" as now made. It consists essentially of a small telescope and level, the telescope being mounted in standards, in which it can be elevated or depressed. The standard revolves around an axis, called the polar axis, which is fastened to the telescope axis of the transit instrument. The telescope called the "Solar Telescope" can thus be moved in altitude and azimuth. Two pointers attached to the telescope to approximately set the instrument are so adjusted that when the shadow of the one is thrown on the other the sun will appear in the field of view.

Adjustment of the Apparatus.

1. The Transit must be in perfect adjustment, especially the levels on the telescope and the plates; the cross axis of the telescope should be exactly horizontal, and the index error of the vertical circle carefully determined.

2. The Polar axis must be at right angles to the line of collimation and horizontal axis of main telescope.

To effect this, level the instrument carefully and bring the bubble of each telescope level to the middle of its scale. Revolve the Solar around its polar axis, and if the bubble remains central the adjustment is complete. If not, correct half the movement by adjusting screws at the base of the polar axis, and the other half by moving the solar telescope on its horizontal axis.

3. The line of collimation of the solar telescope and the axis of its level must be parallel.

To effect this bring both telescopes in the same vertical plane and both bubbles to the middle of their scales. Observe a mark through the transit telescope, and note whether the solar telescope points to a mark above this, equal

to the distance between the horizontal axes of the two telescopes. If it does not bisect this mark, move the cross wires by means of the screws until it does. Generally the small level has no adjustments and the parallelism is affected only by moving the cross hairs.

The adjustments of the Transit and the Solar should be frequently examined and kept as nearly perfect as possible.

Directions for using the Attachment.

First. Take the declination of the sun as given in the Nautical Almanac for the given day, and correct it for refraction and hourly change. Incline the transit telescope until this amount is indicated by its vertical arc. If the declination of the sun is north, depress it; if south, elevate it. Without disturbing the position of the transit telescope, bring the solar telescope into the vertical plane of the large telescope and to a horizontal position by means of its level. The two telescopes will then form an angle which equals the amount of the declination, and the inclination of the solar telescope to its polar axis will be equal to the polar distance of the sun.

Second. Without disturbing the relative positions of the two telescopes, incline them and set the vernier to the co-latitude of the place.

By moving the transit and the "Solar Attachment" around their respective vertical axes, the image of the sun will be brought into the field of the solar telescope, and after accurately bisecting it the transit telescope must be in the meridian, and the compass-needle indicates its deviation at that place.

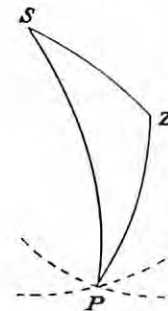

The vertical axis of the "Solar Attachment" will then point to the pole, the apparatus being in fact a small equatorial.

Time and azimuth are calculated from an observed altitude of the sun by solving the spherical triangle formed by the sun, the pole, and the zenith of the place. The three sides, $S P$, $P Z$, $Z S$, complements respectively of the declination, latitude, and altitude, are given, and we hence deduce $S P Z$, the hour angle, from apparent noon, and $P Z S$ the azimuth

of the sun.

The "Solar Attachment" solves the same spherical triangle by construction, for the second process brings the vertical axis of the solar telescope to the required distance, $Z P$, from the zenith, while the first brings it to the required distance, $S P$, from the sun.

Observation for Time.

If the two telescopes, both being in position—one in the meridian, and the other pointing to the sun—are now turned on their horizontal axes, the vertical remaining undisturbed, until each is level, the angle between their directions (found by sighting on a distant object) is $S P Z$, the time from apparent noon.

This gives an easy observation for correction of time-piece, reliable to within a few seconds.

To obtain the Latitude with the "Saegmuller Solar Attachment."

Level the Transit carefully and point the telescope toward the south and elevate or depress the object-end, according as the declination of the sun is south or north, an amount equal to the declination.

Bring the solar telescope into the vertical plane of the main telescope, level it carefully and clamp it. With the solar telescope observe the sun a few minutes before its culmination; bring its image between the two horizontal wires by moving the transit telescope in altitude and azimuth, and keep it so by the slow motion screws until the sun ceases to rise. Then take the reading of the vertical arc, correct for refraction due to altitude by the table below. Subtract the result from 90°, and the remainder is the latitude sought.

Mean Refraction.

Barometer 30 inches, Fahrenheit thermometer 50°.

Altitude.	Refraction.	Altitude.	Refraction.
10°	5' 19"	20°	2' 39"
11	4 51	25	2 04
12	4 27	30	1 41
13	4 07	35	1 23
14	3 49	40	1 09
15	3 34	45	58
16	3 20	50	49
17	3 08	60	34
18	2 57	70	21
19	2 48	80	10

The following table, computed by Prof. Johnson, C. E., Washington University, St. Louis, will be found of considerable value in solar compass work:

"This table is valuable in indicating the errors to which the work is liable at different hours of the day and for different latitudes, as well as serving to correct the observed bearings of lines when it afterwards appears that a wrong latitude or declination has been used. Thus on the first day's observations I used a latitude in the forenoon of 38° 37', but when I came to make the meridian observation for latitude I found the instrument gave 38° 39'. This was the latitude that should have been used, so I corrected the morning's observations for two minutes error in latitude by this table.

"It is evident that if the instrument is out of adjustment the latitude found by a meridian observation will be in error; but if this observed latitude be used in setting off the co-latitude the instrumental error is eliminated. Therefore always use for the co-latitude that given by the instrument itself in a meridian observation."

Errors in Azimuth (by Solar Compass) for 1 Min. Error in Declination or Latitude.

Hour.	For 1 Min. Error in Declination.			For 1 Min. Error in Latitude.		
	Lat. 30°.	Lat. 40°.	Lat. 50°.	Lat. 30°.	Lat. 40°.	Lat. 50°.
	Min.	Min.	Min.	Min.	Min.	Min.
11.30 A. M.	8.85	10.00	12.90	8.77	9.92	11.80
12.30 P. M.						
11 A. M.	4.46	5.05	6.01	4.33	4.87	5.80
1 P. M.						
10 A. M.	2.31	2.61	3.11	2.00	2.26	2.70
2 P. M.						
9 A. M.	1.63	1.83	2.20	1.15	1.30	1.56
3 P. M.						
8 A. M.	1.34	1.51	1.80	0.67	0.75	0.90
4 P. M.						
7 A. M.	1.20	1.35	1.61	0.31	0.35	0.37
5 P. M.						
6 A. M.	1.15	1.30	1.56	0.00	0.00	0.60
6 P. M.						

NOTE.—Azimuths observed with erroneous declination or co-latitude may be corrected by means of this table by observing that for the line of collimation set too high the azimuth of any line from the south point in the direction S. W. N. E. is found too small in the forenoon and too large in the afternoon by the tabular amounts for each minute of error in the altitude of the line of sight. The reverse is true for the line set too low.

Correction for Refraction.

This correction is applied to the declination of the sun, and is equal to the refraction-correction of the sun's observed altitude multiplied by the cosine of the angle which the sun makes between the declination-circle and the vertical.

In order to reduce the refraction correction to the simplest possible form, we have added a separate column to the ephemeris containing them, which we publish every year. They are thus brought in immediate juxtaposition with the declination angle, and we think the arrangement will be appreciated by those who use the Solar Attachment.

Latitude Coefficients.

Lat.	Coeff.	Lat.	Coeff.	Lat.	Coeff.	Lat.	Coeff.
15°	.30	27°	.56	39°	.96	51°	1.47
16	.32	28	.59	40	1.00	52	1.53
17	.34	29	.62	41	1.04	53	1.58
18	.36	30	.65	42	1.08	54	1.64
19	.38	31	.68	43	1.12	55	1.70
20	.40	32	.71	44	1.16	56	1.76
21	.42	33	.75	45	1.20	57	1.82
22	.44	34	.78	46	1.24	58	1.88
23	.46	35	.82	47	1.29	59	1.94
24	.48	36	.85	48	1.33	60	2.00
25	.50	37	.89	49	1.38		
26	.53	38	.92	50	1.42		

Refraction Correction Lat. 40°

January.		February.		March.		April.		May.		June.	
1	1h.1 58	1		1	1h.1 03	1	2h.0 57	1	1h.0 28	1	5h.1 11
2	2 2 10	2		2	2 1 10	2	4 1 10	2	2 0 32	2	
3	3 3 04			3	3 1 27	3	5 2 18	3	3 0 39	3	1 0 10
4	4 4 23			4	4 2 06	4	6 3 08	4	4 0 55	4	2 0 23
5	1 1 54	3	1h.1 20	5	5 4 30	5	1 0 39	5	5 1 30	5	3 0 33
6	2 2 11	4	2 1 37	6	1 0 59	6	2 0 44	6	1 0 26	6	4 0 43
7	3 2 59	5	3 2 04	7	2 1 08	7	3 0 54	7	2 0 30	7	5 1 10
8	4 4 01	6	4 3 21	8	3 1 21	8	4 1 14	8	3 0 37	8	1 0 18
9	1 1 51	7	1 1 21	9	4 1 56	9	5 2 08	9	4 0 53	9	2 0 22
10	2 2 07	8	2 1 31	10	5 4 04	10	1 0 30	10	5 1 20	10	3 0 29
11	3 2 51	9	3 1 56	11	1 0 55	11	2 0 41	11	1 0 25	11	4 0 43
12	4 4 21	10	4 3 04	12	2 1 02	12	3 0 51	12	2 0 29	12	5 1 09
13	1 1 46	11	1 1 14	13	3 1 15	13	4 1 10	13	3 0 33	13	1 0 18
14	2 2 01	12	2 1 25	14	4 1 47	14	1 0 34	14	4 0 51	14	2 0 21
15	3 2 40	13	3 1 48	15	5 3 34	15	2 0 38	15	1 0 23	15	3 0 29
16	4 4 00	14	4 2 47	16	1 0 52	16	3 0 48	16	2 0 27	16	4 0 42
17	1 1 42	15	5 3 30	17	2 0 58	17	4 1 06	17	3 0 34	17	5 1 08
18	2 1 58	16	1 1 12	18	3 1 10	18	1 0 32	18	4 0 49	18	1 0 18
19	3 2 22	17	1 1 20	19	4 1 39	19	2 0 36	19	1 0 22	19	2 0 22
20	4 4 07	18	2 1 40	20	5 3 08	20	3 0 45	20	2 0 26	20	3 0 28
21	1 1 32	19	3 1 40	21	1 0 48	21	4 1 02	21	3 0 33	21	4 0 42
22	2 1 44	20	4 2 31	22	2 0 54	22	5 1 42	22	4 0 47	22	5 1 04
23	3 2 13	21	5 4 49	23	3 1 05	23	1 0 30	23	5 1 15	23	1 0 18
24	4 4 35	22	1 1 07	24	4 1 32	24	2 0 34	24	1 0 21	24	2 0 22
25	1 1 37	23	2 1 15	25	5 2 51	25	3 0 42	25	2 0 25	25	3 0 29
26	2 1 59	24	3 1 33	26	1 0 45	26	4 0 58	26	3 0 32	26	4 0 43
27	3 2 22	25	4 2 18	27	2 0 50	27	5 1 36	27	4 0 46	27	5 1 09
28	4 4 07	26	5h.5 28	28	3 1 01	28	1 0 28	28	5 1 13	28	1 0 18
29	1 1 32	27		29	4 1 25	29	2h.0 32	29	1 0 20	29	2 0 22
30	2 1 44	28		30	5 2 34	30		30	2 0 24	30	3 0 29
31	3 2 13			31	1 0 42			31	3 0 31		4h.0 43
	4h.3 41				2h.0 47				4 0 44		

July.		August.		September.		October.		November.		December.	
1	5h.1 09	1		1	1h.0 39	1	1h.0 50	1	2h.3 21	1	1h.1 54
2		2		2	2 0 44	2	2 1 06	2	3 13 57	2	2 2 11
3	1 0 19	3	1h.0 26	3	3 0 54	3	3 1 21	3	4	3	3 2 59
4	2 0 23	4	2 0 30	4	4 1 14	4	4 1 56	4	5	4	4 0 01
5	3 0 30	5	3 0 37	5	5 2 08	5	5 4 04	5	1 1 32	5	5
6	4 0 43	6	4 0 53	6	1 0 42	6	1 1 03	6	2 1 44	6	1 1 58
7	5 1 10	7	5 1 26	7	2 0 47	7	2 1 10	7	3 2 13	7	2 2 16
8	1 0 20	8	1 0 28	8	3 0 57	8	3 1 27	8	4 3 41	8	3 3 04
9	2 0 24	9	2 0 32	9	4 1 19	9	4 2 06	9	5	9	4 6 23
10	3 0 31	10	3 0 39	10	5 2 18	10	5 4 39	10	1 1 37	10	5
11	4 0 44	11	4 0 55	11	1 0 45	11	1 1 07	11	2 1 50	11	1 2 00
12	5 1 11	12	5 1 30	12	2 0 50	12	2 1 15	12	3 2 22	12	2 2 19
13	1 0 21	13	1 0 30	13	3 1 01	13	3 1 33	13	4 4 07	13	3 3 09
14	2 0 25	14	2 0 34	14	4 1 25	14	4 2 18	14	5	14	4 6 38
15	3 0 32	15	3 0 42	15	5 2 34	15	5 5 30	15	1 1 42	15	5
16	4 0 46	16	4 0 58	16	1 0 48	16	1 1 12	16	2 1 56	16	1 2 01
17	5 1 13	17	5 1 36	17	2 0 54	17	2 1 20	17	3 2 31	17	2 2 20
18	1 0 22	18	1 0 32	18	3 1 05	18	3 1 40	18	4 4 35	18	3 3 11
19	2 0 26	19	2 0 36	19	4 1 32	19	4 2 31	19	5	19	4 6 47
20	3 0 33	20	3 0 45	20	5 2 51	20	5 5 29	20	1 1 45	20	5
21	4 0 47	21	4 1 02	21	1 0 52	21	1 1 16	21	2 2 01	21	1 2 01
22	5 1 15	22	5 1 42	22	2 0 58	22	2 1 25	22	3 2 40	22	2 2 20
23	1 0 23	23	1 0 34	23	3 1 10	23	3 1 48	23	4 4 59	23	3 3 11
24	2 0 27	24	2 0 38	24	4 1 39	24	4 2 47	24	5	24	4 6 49
25	3 0 34	25	3 0 48	25	5 3 08	25	5 8 39	25	1 1 50	25	5
26	4 0 49	26	4 1 08	26	1 0 55	26	1 1 21	26	2 2 08	26	1 2 00
27	5 1 18	27	5 1 49	27	2 1 02	27	2 1 31	27	3 2 49	27	2 2 19
28	1 0 25	28	1 0 36	28	3 1 15	28	3 1 56	28	4 5 33	28	3 3 09
29	2 0 29	29	2 0 41	29	4 1 47	29	4 3 04	29	5h.	29	4 6 48
30	3 0 36	30	3 0 51	30	5h.3 34	30	5 11 01	30		30	5h.
31	4 0 51	31	4 1 10				1h.1 25			31	
	5h.1 22		5h.1 58				1 37				
							2 04				

The Preparation of the Declination Settings for a Day's Work.

The Solar Ephemeris* gives the declination of the sun for the given day, for Greenwich mean noon. Since all points in America are west of Greenwich, by 5, 6, 7, or 8 hours, the declination found in the ephemeris is the declination at the given place at 7, 6, 5, or 4 o'clock A. M., of the same date, according as the place lies in the "Eastern," "Central," "Mountain," or "Western Time" belts, respectively.

The column headed "Refraction Correction" gives the correction to be made to the declination, for refraction, for any point whose latitude is 40°. If the latitude is more or less than 40° these corrections are to be multiplied by the corresponding coefficients given in the table of "Latitude Coefficients," p. 25. Thus the refraction corrections in latitude 30° are 65 hundredths, and those of 50° 142 hundredths of the corresponding ones in latitude 40°. There is a slight error in the use of these latitude coefficients, but the maximum error will not amount to over 15", except when the sun is very near the horizon, and then any refraction becomes very uncertain. All refraction tables are made out for the mean, or average, refraction, whereas the actual refraction at any particular time and place may be not more than one-half, or as much as twice the mean refraction, with small altitudes. The errors made in the use of these latitude coefficients are, therefore, very small as compared with the errors resulting from the use of the mean, rather than unknown actual refraction which affects any given observation.

Example I.

Let it be required to prepare a table of declinations for a point whose latitude is 38° 30', and which lies in the "Central Time" belt, for April 5, 1890.

Since the time is 6 hours earlier than that at Greenwich, the declination given in the ephemeris is the declination here at 6 A. M. of same date. This is found to be + 6° 9' 57". To this must be added the hourly change, which is also plus, and equal to 56" .83. The latitude coefficient is 0.94. The following table may now be made out:

Declination Settings for Apr. 5, 1890, Lat. 38° 30', Central Time.

Hour.	Declination.	Ref. Cor.	Setting.	Hour.	Declination.	Ref. Cor.	Setting.
7	+ 6° 10' 54"	+ 2' 00"	6° 12' 54"	1	6° 16' 35"	+ 37"	6° 17' 12"
8	6 11 51	+ 1 10	6 13 01	2	6 17 31	+ 41	6 18 12
9	6 12 47	+ 51	6 13 38	3	6 18 28	+ 51	6 19 19
10	6 13 41	+ 41	6 14 25	4	6 19 25	+ 1 10	6 20 35
11	6 14 41	+ 37	6 15 18	5	6 20 22	+ 2 00	6 22 22

* We publish the Solar Ephemeris every year and send it to any one applying for it.

Example II.

Let it be required to prepare a declination table for a point in lat. 45°, in the "Eastern Time" belt, for Oct. 10, 1890.

The time now is 5 hours earlier than that of Greenwich, hence the declination given in the ephemeris for Greenwich mean noon is the declination at our point at 7 A. M. The declination found is — 6° 43' 56", and the hourly change is — 56'.87. The latitude coefficient is 1.20.

The table then becomes :

Declination Settings for Oct. 10, 1890. Lat. 45°, Eastern Time.

Hour.	Declination	Ref. Cor.	Settings.	Hour.	Declination.	Ref. Cor.	Settings.
7	— 6° 43' 56"	+ 5' 35"	— 6° 38' 21"	1	— 6° 49' 37"	+ 1' 16"	— 6° 48' 21"
8	— 6 44 53	+ 2 31	— 6 42 22	2	— 6 50 34	+ 1 24	— 6 49 10
9	— 6 45 50	+ 1 44	— 6 44 06	3	— 6 51 31	+ 1 44	— 6 49 47
10	— 6 46 47	+ 1 24	— 6 45 23	4	— 6 52 28	+ 2 31	— 6 49 57
11	— 6 47 44	+ 1 16	— 6 46 28	5	— 6 53 25	+ 5 35	— 6 47 50

If the date be between June 20 and Sept. 20 the declination is positive and the hourly change negative, while if it be between Dec. 20 and March 20 the declination is negative and the hourly change positive. The refraction correction is always positive; that is, it always increases numerically the north declinations and diminishes numerically the south declinations. The hourly refraction corrections given in the ephemeris are exact for the middle day of the five-day period corresponding to that set of hourly corrections. For the extreme days of any such period an interpolation can be made between the adjacent hourly corrections, if desired.

By using standard time instead of local time a slight error is made, but the maximum value of this error is found at those points where the standard time differs from the local time by one half hour, and in the spring and fall when the declination is changing rapidly. The greatest error, then, is less than 30", and this is smaller than can be set off on the vertical circle or declination arc. Even this error can be avoided by using the true difference of time from Greenwich in place of the standard meridian time.

New Quick-Levelling Tripod-Head with Shifting-Plate.

PATENTED BY G. N. SÆGMULLER, WASHINGTON, D. C.

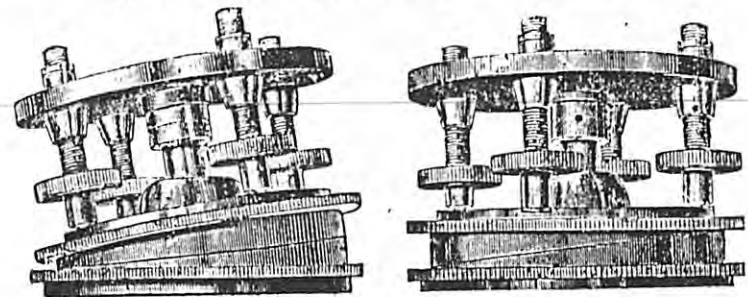

These engravings represent a new form of Quick-Levelling Tripod, which is the simplest and most convenient yet devised. It consists of two circular disks, which are wedged shaped; that is, thicker on one side than the other. They are interposed between the levelling-screws and tripod-head proper. By turning one or the other of them around their common centre the instrument can gradually be brought to a vertical position. The final levelling touches are given by means of the usual levelling-screws, which at the same time clamp the instrument firmly. *The great advantage of this Quick-Levelling Tripod over other forms is that the instrument will not fall over even if it is not clamped, and no accident in this account can occur.*

It can be attached to any transit or levelling instrument.

New Vertical Sighting Prism for Mining Transits.

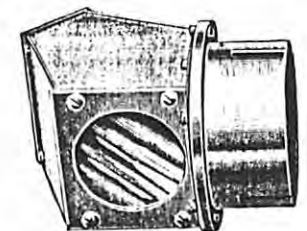
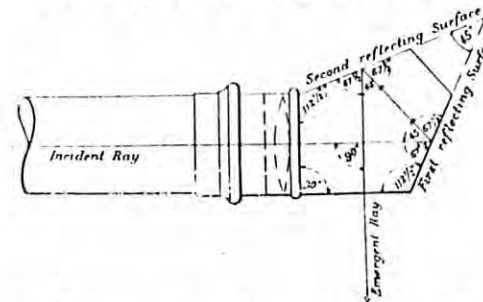

This device consists of a double reflecting prism, with the angles so arranged that a ray which has been reflected *twice* in the same plane makes, after its second reflection, an angle with its original direction equal to twice the angle made by the reflecting surfaces with each other.

So it makes no difference whether the prism is placed exactly at right angles to the telescope or not; it will throw the rays *vertically* if the Transit is placed in a *horizontal* position.

It is, however, essential that there be no shake in the draw tube, and it is preferable to be used with telescopes with fixed object glass and where the eye-piece is focussed.

Price of complete prism..... \$55 00

PHOTO-CHRONOGRAPH.

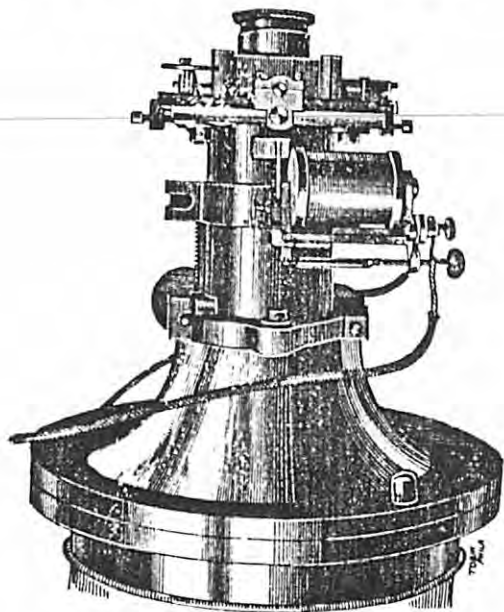

The Georgetown College Photo-Chronograph,

as designed by Prof. Geo. A. Fargis, S. J.

By means of this attachment the time of the transit of a star is actually registered on the plate, as the name very aptly suggests.

It consists of two parts: a plate-holder and an electro-magnet, and is so arranged that sensitive plates can be inserted close against the glass reticle into the photographic focus of the object glass. To facilitate the insertion the eye-piece slide is hinged, allowing it to be moved out of the way.

A brass collar fits closely around the sliding tube, just behind the micrometer box, and to this collar is attached the electro-magnet, which consists of only one coil in order to diminish weight. The end of the core is cushioned with a thin ring of cork to destroy the force of the armature stroke. The usual adjusting and connecting screws are conveniently placed. A thin, narrow strip of steel, called the occulter bar, is fastened to the armature at right angles to its line of motion and protrudes through a hole in the box across the field. The coil, armature, and occulter bar are so fixed to the collar that, when at rest, the lower edge of the shutter is parallel to the horizontal diameter of the reticle.

 DESCRIPTIVE PRICE-LIST

— OF —

FIRST-CLASS

Engineering and Astronomical Instruments

MANUFACTURED BY

GEORGE N. SAEGMULLER,

SUCCESSOR TO FAUTH & CO.

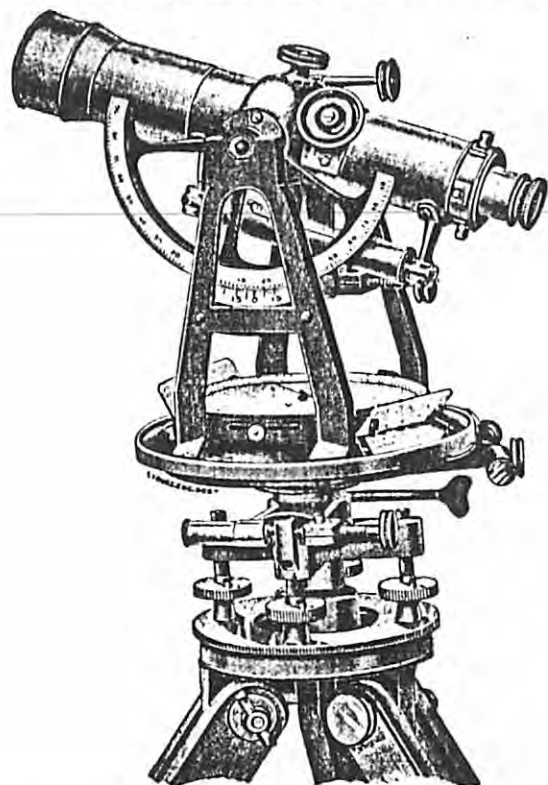

Four-inch Mining Transit.

Designed especially for use in rough country and mine work, and differs from our regular Engineer's Transits merely in size and weight. This instrument will do most accurate work, and in order not to sacrifice the optical power we make the telescope of the inverting kind, which gives us nearly the same power we get with the ordinary Engineer's telescope possessing the erecting telescope.

The telescope is 7½ inches long and magnifies about 16 diameters; 4-inch circle and arc graduated on solid silver reading to minutes; compass-needle 3¾ inches long; long sensitive level to telescope; dust-guard to object slide. The telescope axis is arranged so that the Saegmuller solar can be added to it at any time. Weight about 5 pounds. Packed in box complete with usual accessories.

Price.....	\$225 00
With Extension Tripod (weight 5 lbs.), \$10 extra.	
Extras for Mining Transit.	
Fixed stadins.....	\$3 00
Eye-piece prism and sun glass.....	8 50

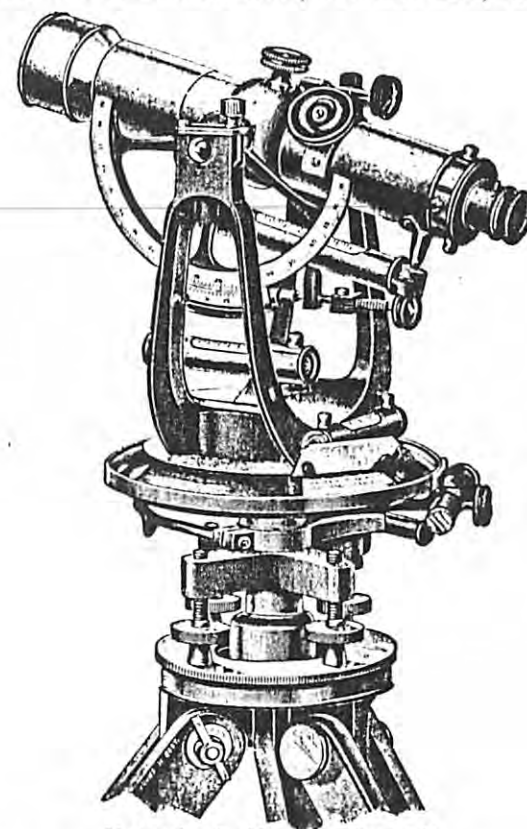

Four-inch Mining Transit.

Like the preceding, but having U standards and no compass. Weight 5 lbs.
 Price..... \$200 00
 Extension Tripod (weight 5 lbs.), \$10 extra.

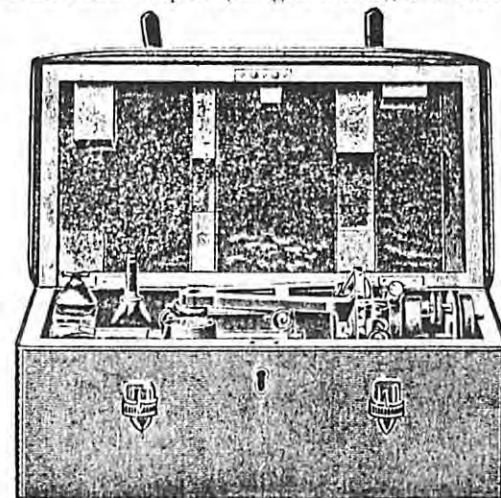

Mode of Packing 4-inch Mining Transit.

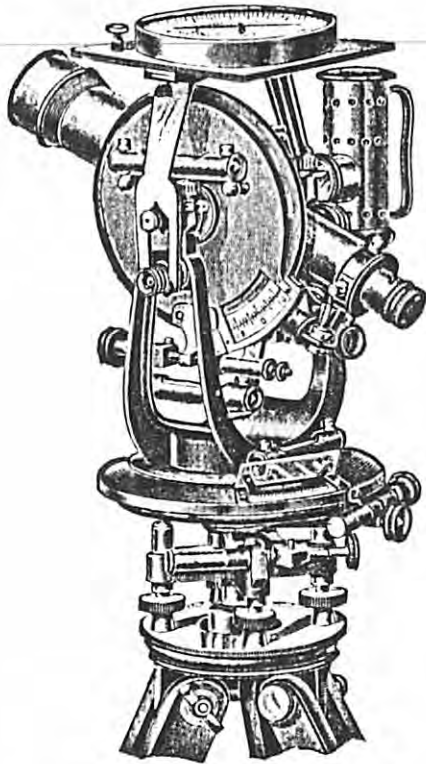

Four-inch Mining Transit.

With U standards, full vertical circle, detachable compass, illumination for cross-hairs with lamp. Weight about 5½ lbs.

Price..... \$275 00

Extension Tripod (weight 5 lbs.), \$10 extra.

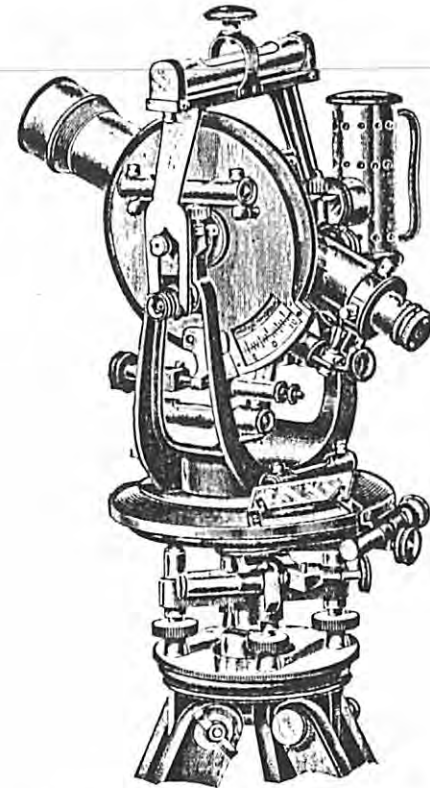

Four-inch Mining Transit.

With U standards, full vertical circle, illumination to cross-hairs, with striding level. Weight about 5¼ lbs.

Price..... \$275 00

Extension Tripod (weight 5 lbs.), \$10 extra.

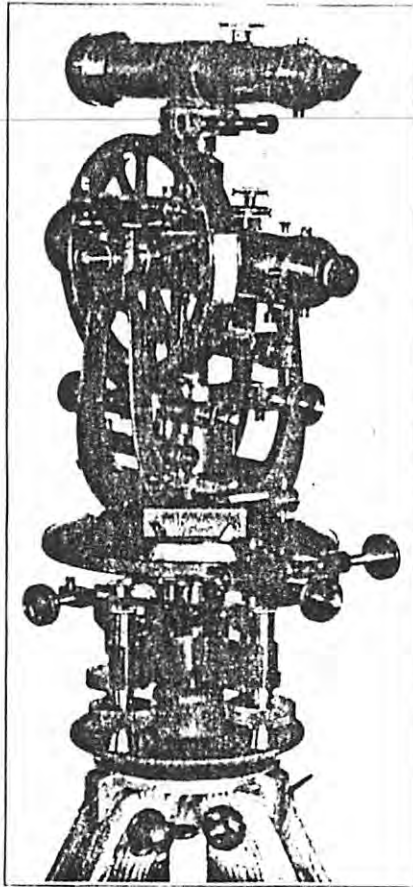

Four-inch Mining Transit.

With "Scott" top telescope, full vertical circle, divided on edge with opposite verniers reading to minutes.

Price..... \$300 00

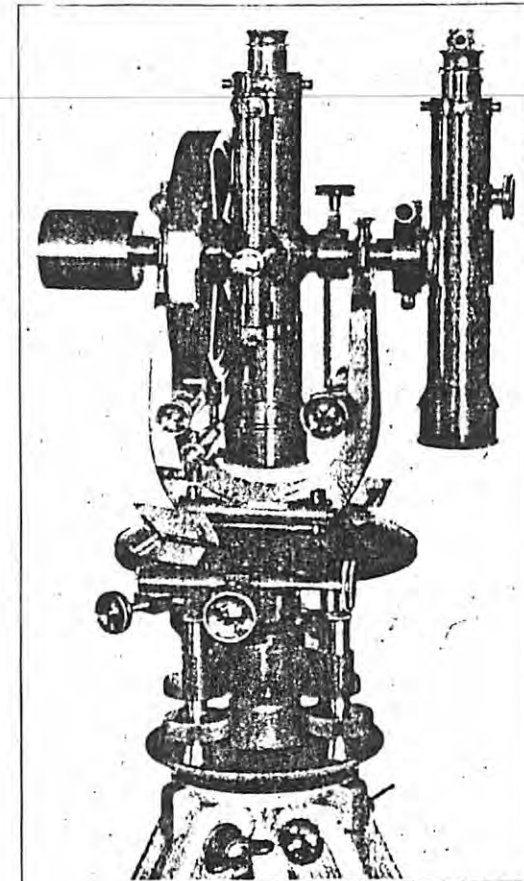

Four-inch Mining Transit.

Like the preceding, with top telescope changed to side.

Price..... \$300 00

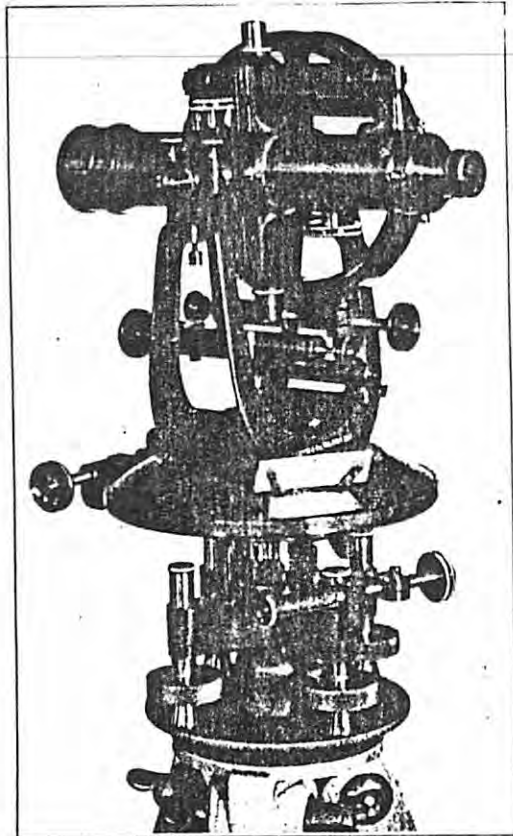

Four-inch Mining Transit.

Like the preceding, top telescope removed.

Price..... \$250 00

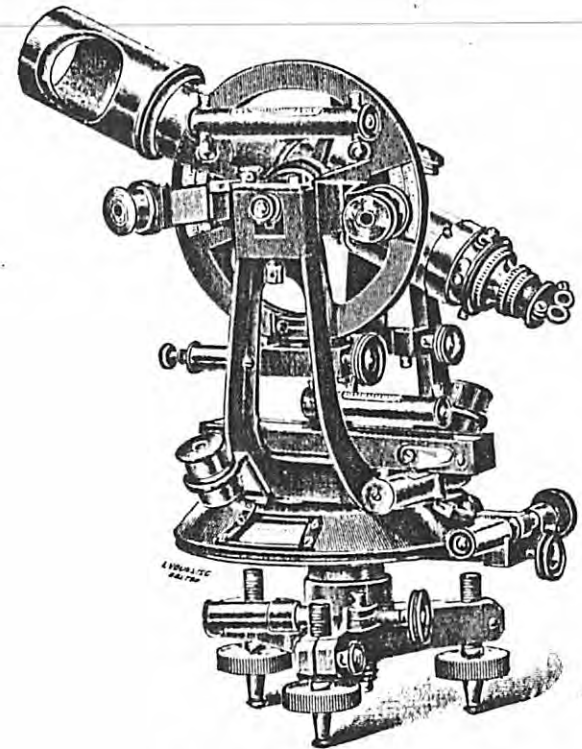

Four-inch Theodolite,
As furnished to the U. S. Government Surveys.

The circles, with opposite verniers, read to 30". It has 3 levelling screws.
Completely packed, with Tripod..... \$300 00

5-inch Plain Mining Transit, No. 1.

This Transit has a *beveled-edge* circle of $5\frac{1}{4}$ inches diameter at the graduation, and is divided on silver into $\frac{1}{2}^\circ$, reading by opposite double verniers to single minutes. Plate levels are *inside* of compass-box; needle $3\frac{3}{4}$ inches long. Compass and vernier openings *water-tight*. *Erecting* telescope 10 inches long. $1\frac{1}{8}$ inches aperture, power 18 diameters.

Weight of instrument 9 pounds, tripod about $6\frac{1}{2}$ pounds.

Price.....	\$180 00
Same with silvered graduation.....	170 00

6-inch Plain Mining Transit.

Circle $6\frac{3}{4}$ inches diameter; *beveled edge*, graduated on silver into $\frac{1}{2}^\circ$, reading by opposite double verniers to single minutes. Plate levels *inside* of compass-box; needle $4\frac{1}{2}$ inches long. Compass and vernier openings *water-tight*. *Erecting* telescope $11\frac{1}{2}$ inches, $1\frac{1}{4}$ inches aperture, power 24 diameters.

Weight of instrument 12 pounds, tripod about $6\frac{1}{2}$ pounds.

Price.....	\$195 00
------------	----------

Extras.

If graduation is wanted to read to 30 seconds, limb being graduated into $\frac{1}{3}^\circ$, the cost will be \$10 additional for the above instruments.

Variation plate can be added at an additional cost of.....	\$10 00
Gradientor.....	5 00
Fixed stadins.....	3 00
Adjustable stadins.....	10 00
Saegmuller's Quick Levelling Head.....	10 00
Extension Tripod (in place of ordinary).....	10 00
Eye-piece prism and sun glass.....	8 50

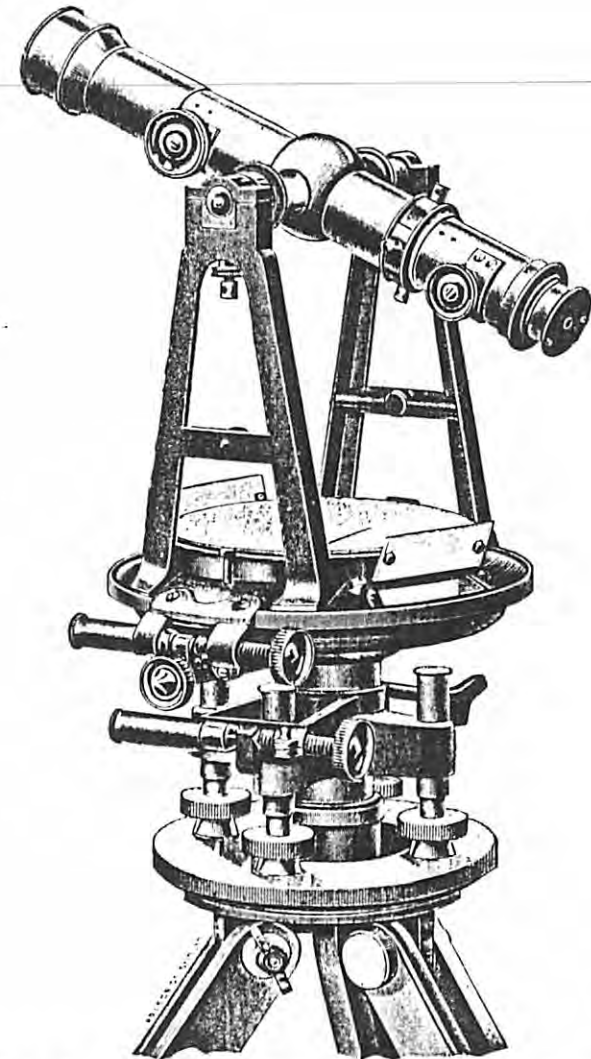

5-inch and 6-inch Plain Mining Transit, No. 1.

5-inch Mining Transit, No. 2, with vertical arc, level, clamp, and tangent to telescope.

Circle $5\frac{1}{4}$ inches diameter; *beveled edge*, graduation on silver into $\frac{1}{2}^\circ$, reading to single minutes by double opposite verniers; 5-inch vertical arc, divided on silver and reading to minutes. Plate levels *inside* compass-box; compass and vernier openings *water-tight*; needle $3\frac{3}{4}$ inches long. *Erecting* telescope 10 inches long, $1\frac{1}{4}$ inches aperture, power 18 diameters. Sensitive level to telescope.

Weight of instrument 10 pounds, tripod about 7 pounds.

Price..... \$230 00
Same with graduations silvered..... 215 00

6-inch Mining Transit, No. 2, with vertical arc, level, clamp, and tangent to telescope.

Circle $6\frac{3}{4}$ inches diameter; *beveled edge*, graduated on silver into $\frac{1}{2}^\circ$, reading by opposite double verniers to single minutes; 5-inch vertical arc, divided on silver, reading to minutes. Plate levels *inside* of compass-box; needle $4\frac{1}{2}$ inches long. Compass and vernier openings *water-tight*. *Erecting* telescope $11\frac{1}{2}$ inches long, $1\frac{1}{4}$ inches aperture, power 24 diameters. Sensitive level to telescope.

Weight of instrument 13 pounds, tripod about 7 pounds.

Price..... \$245 00

Extras.

If graduation is wanted to read to 30 seconds, limb being graduated into $\frac{1}{4}^\circ$, the cost will be \$10 additional for above instruments.

Variation plate can be added at an additional cost of.....	\$10 00
Gradientor.....	5 00
Fixed stadias.....	3 00
Adjustable stadias.....	10 00
Saegmuller's Quick Levelling Head.....	10 00
Extension Tripod (in place of ordinary).....	10 00
Saegmuller's Solar Attachment.....	50 00
Eye-piece prism and sun glass.....	8 50

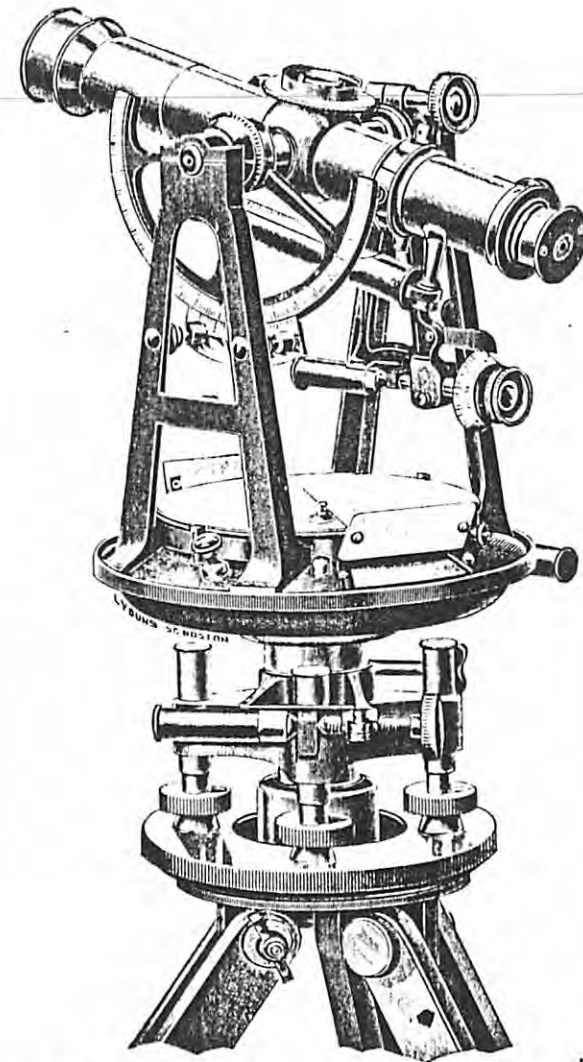

5-inch and 6-inch Mining Transit, No. 2, with vertical arc, level, clamp and tangent to telescope.

5-inch Mining Transit, No. 3, with full vertical circle and double opposite verniers, level, clamp, and tangent to telescope.

Horizontal circle $5\frac{1}{4}$ inches diameter; *beveled edge*, graduation on silver into $\frac{1}{2}^\circ$, reading to single minutes by double opposite verniers. Vertical circle 4 inches diameter, graduated on silver, reading by double *opposite* verniers to minutes. Circle and vernier *completely* covered. Plate levels *inside* compass-box; compass and vernier openings *water-tight*; needle $3\frac{3}{4}$ inches long. *Erecting* telescope 10 inches long, $1\frac{1}{4}$ inches aperture, power 18 diameters. Sensitive level to telescope.

Weight of instrument 11 pounds, tripod about 7 pounds.

Price..... \$250 00

6-inch Mining Transit, No. 3, with full vertical circle and double opposite verniers, level, clamp, and tangent to telescope.

Horizontal circle $6\frac{3}{4}$ inches diameter; *beveled edge*, graduation on silver into $\frac{1}{2}^\circ$, reading to single minutes. Vertical circle $4\frac{1}{2}$ inches diameter, graduated on silver, reading by double *opposite* verniers to minutes. Circle and vernier *completely* covered. Plate levels *inside* compass-box; compass and vernier openings *water-tight*; needle $4\frac{1}{2}$ inches long. *Erecting* telescope $10\frac{1}{2}$ inches long, $1\frac{1}{4}$ inches aperture, power 24 diameters.

Weight of instrument 14 pounds, tripod about $7\frac{1}{2}$ pounds.

Price..... \$265 00

Extras.

If graduations are wanted to read to 30 seconds, limb being graduated into $\frac{1}{3}^\circ$, the cost will be \$10 additional for each circle.

Variation plate can be added at an additional cost of	\$10 00
Gradientor.....	5 00
Fixed stadia.....	3 00
Adjustable stadia.....	10 00
Saegmuller's Quick Levelling Head.....	10 00
Extension Tripod (in place of ordinary).....	10 00
Saegmuller's Solar Attachment.....	50 00
Eye-piece prism and sun glass.....	8 50

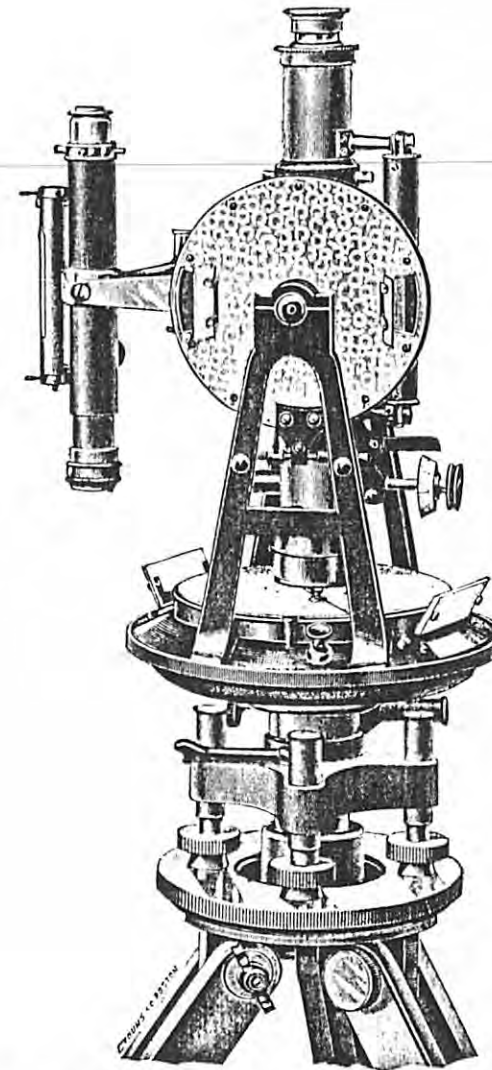

5-inch and 6-inch Mining Transit, No. 3, with full vertical circle and double opposite verniers, level, clamp, and tangent to telescope.

NOTE—The above cut shows this instrument with the Saegmuller Solar, in position for vertical sighting. We make this instrument also with single vernier for vertical circle in place of the double opposite ones, at a reduction of \$10. (See page 36.)

TRANSIT INSTRUMENTS.

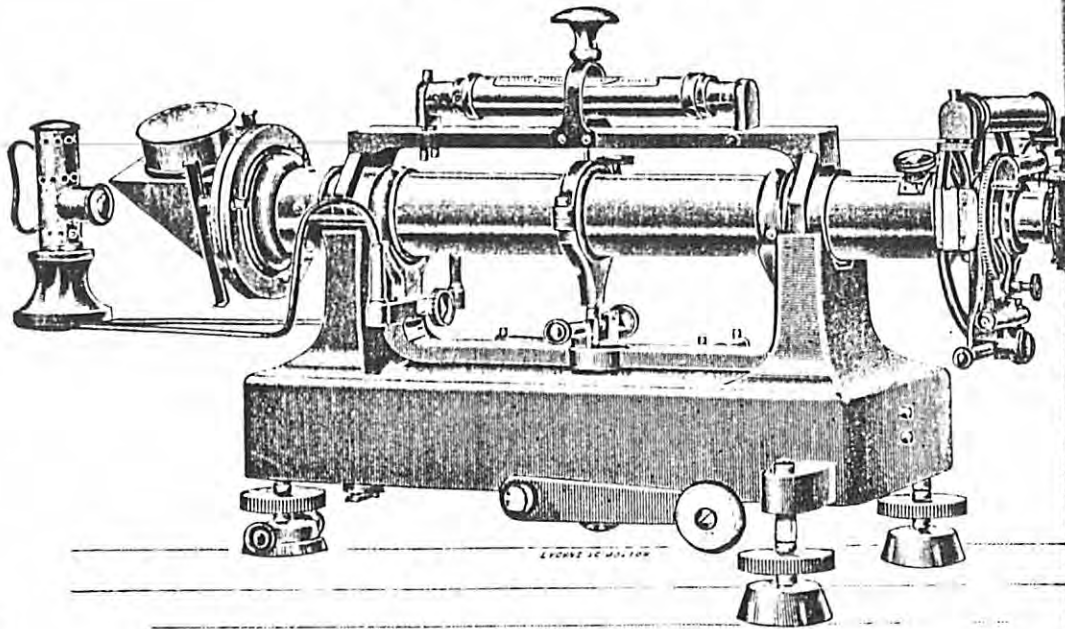

Improved Prismatic Transit.

It has been found that the objections heretofore made to this class of instruments are entirely overcome by the use of Jena glass prisms. It is intended to be set up in the prime vertical, the telescope pointing east and west. By the use of a prismatic objective, any star passing the meridian will be reflected and seen in the field when the instrument is set up correctly; by turning it in its bearings it will sweep the meridian. The pivot-rings are of phosphor bronze, and, to avoid flexure as much as possible, these rings are again connected by a tube, so that the telescope body is really double. By one of the three setting-screws the instrument is moved in azimuth. It is provided with a reversing apparatus, which also carries the illuminating lamp. The fine level over the telescope is held by a projection from the reversing apparatus, which secures the great advantage that the level need not be taken off on reversing the instrument; it remains on whether observing in the zenith or horizon. The setting-circle is attached behind the micrometric eye-piece with level alidade, divided on silver, and reading to minutes. It also carries the latitude level, which is chambered, and reads to single seconds. This instrument, being very simple and portable, is especially adapted for work in a rough or mountainous country.

Telescope of 2½-inch clear aperture, packed complete in box, with two eye-pieces, illuminating and reading lamp, and all accessories. . . . \$950 00

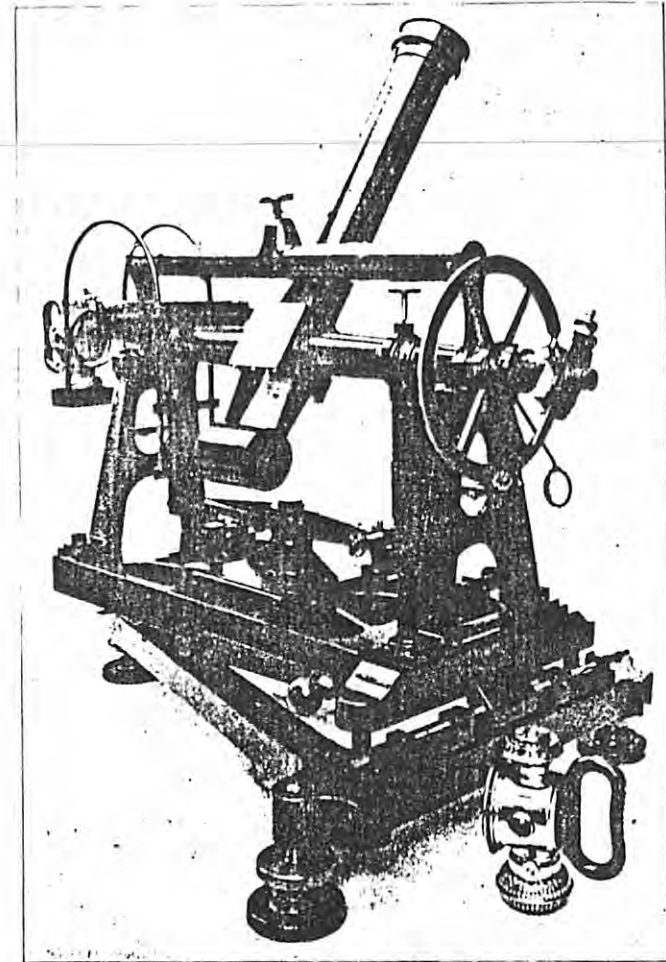

Broken-Back Transit, Navy Pattern.

It is very compact, and as the eye is in the same position, no matter what the elevation of the telescope may be, it is a most convenient instrument to observe with. The telescope has an aperture of 3 inches, both striding and latitude levels reading to single seconds.

Price. \$1,500 00

7-inch Transit Theodolite, with U standards and without compass.

Horizontal circles 7 inches diameter : *beveled edge*, graduated on solid silver into $\frac{1}{4}^{\circ}$, reading by opposite verniers to 30 seconds. Five-inch vertical circle graduated on silver, reading by double *opposite* verniers to 30 seconds. Circle and vernier *completely* covered. *Inverting* telescopes $1\frac{3}{4}$ inches aperture, 11 inches focus, power 30 diameters. Sensitive level attached to telescope. This instrument is generally made with 3 levelling screws.

Weight of instrument 14 pounds, tripod about 8 pounds.

Price..... \$325 00

Extras to above Instrument.

Graduation to read to 10".....	\$25 00
Attached reading glasses to both circles.....	25 00
Sensitive striding level to telescope axis.....	25 00
Illumination through axis with lamp.....	15 00
Eye-piece prism and sun glass.....	8 50
Saegmuller's Solar Attachment.....	50 00

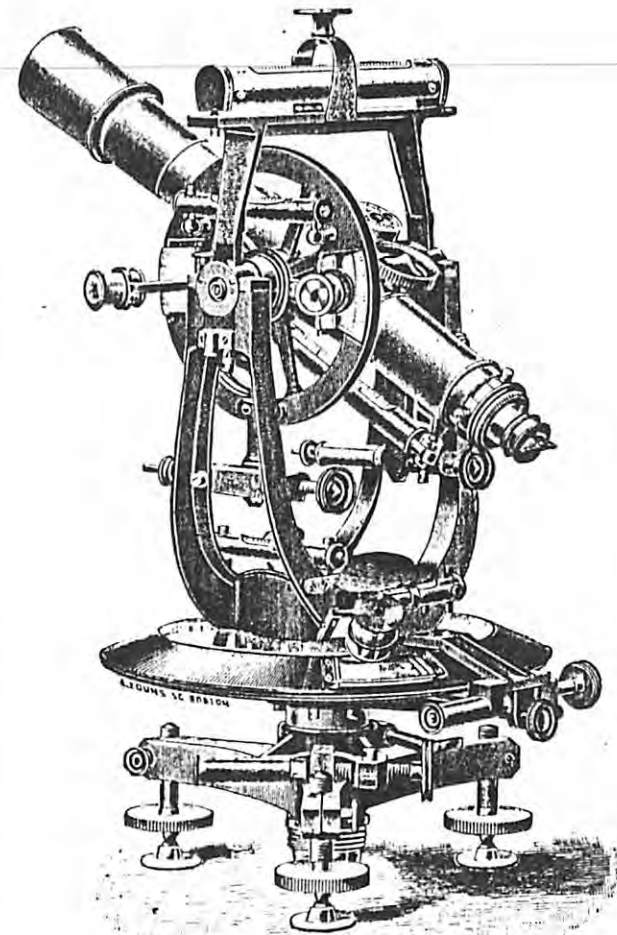

7-inch Complete Transit-Theodolite.

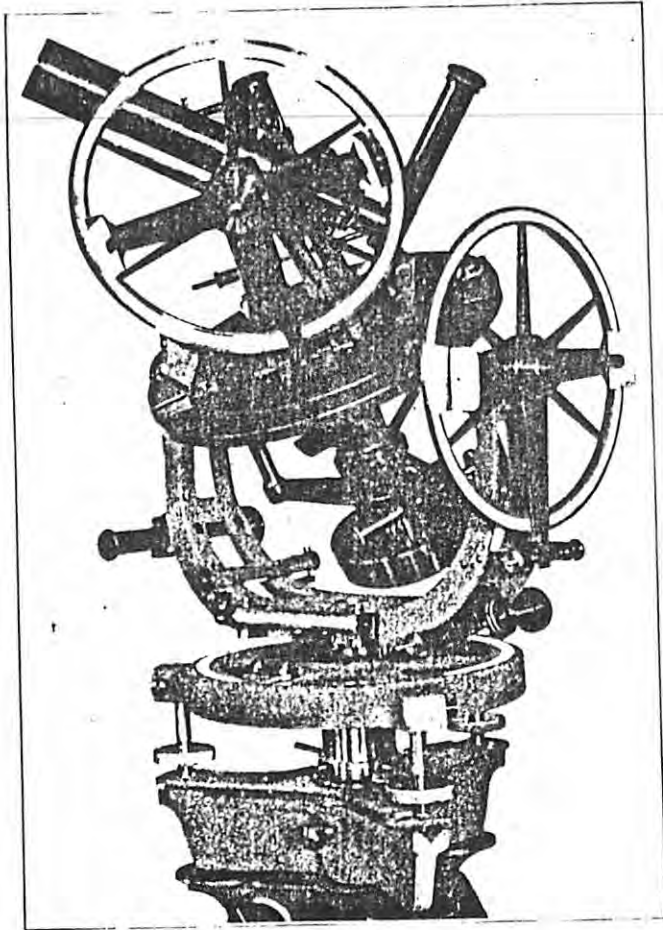

Astronomical Theodolite.

Excellent for purposes of instruction. It is really the highest type of the Solar.

Price..... \$500 00

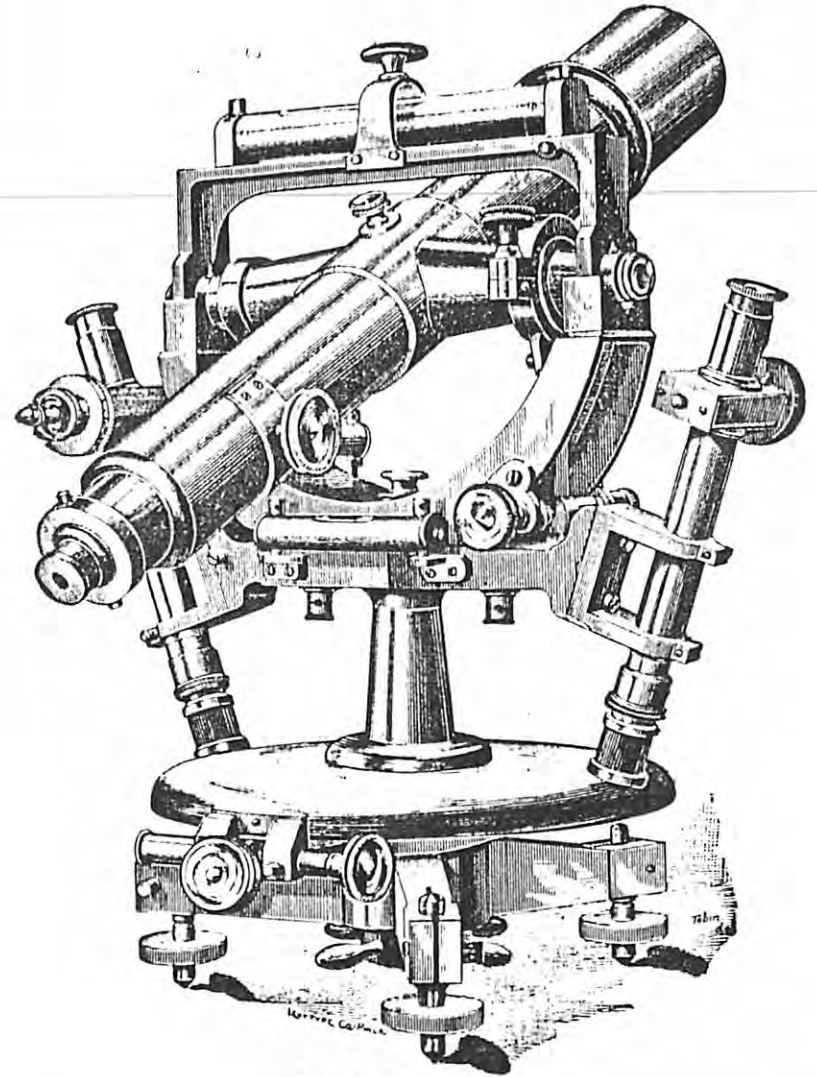

8-inch Theodolite.

Above cut represents an 8-inch Theodolite, especially adapted for triangulation, and is a non-repeater. This is the kind of instrument to which reference is made under head of "Graduation." It reads to seconds by opposite micrometer-microscopes, and every degree is numbered with minute numbers, nearly 1,000 figures, visible only in the microscope, being engraved on the circle. Telescope 1 $\frac{1}{4}$ inches aperture, about 18" focus; improved clamp, sensitive striding-level and field illumination, with stand.

Price..... \$450 00

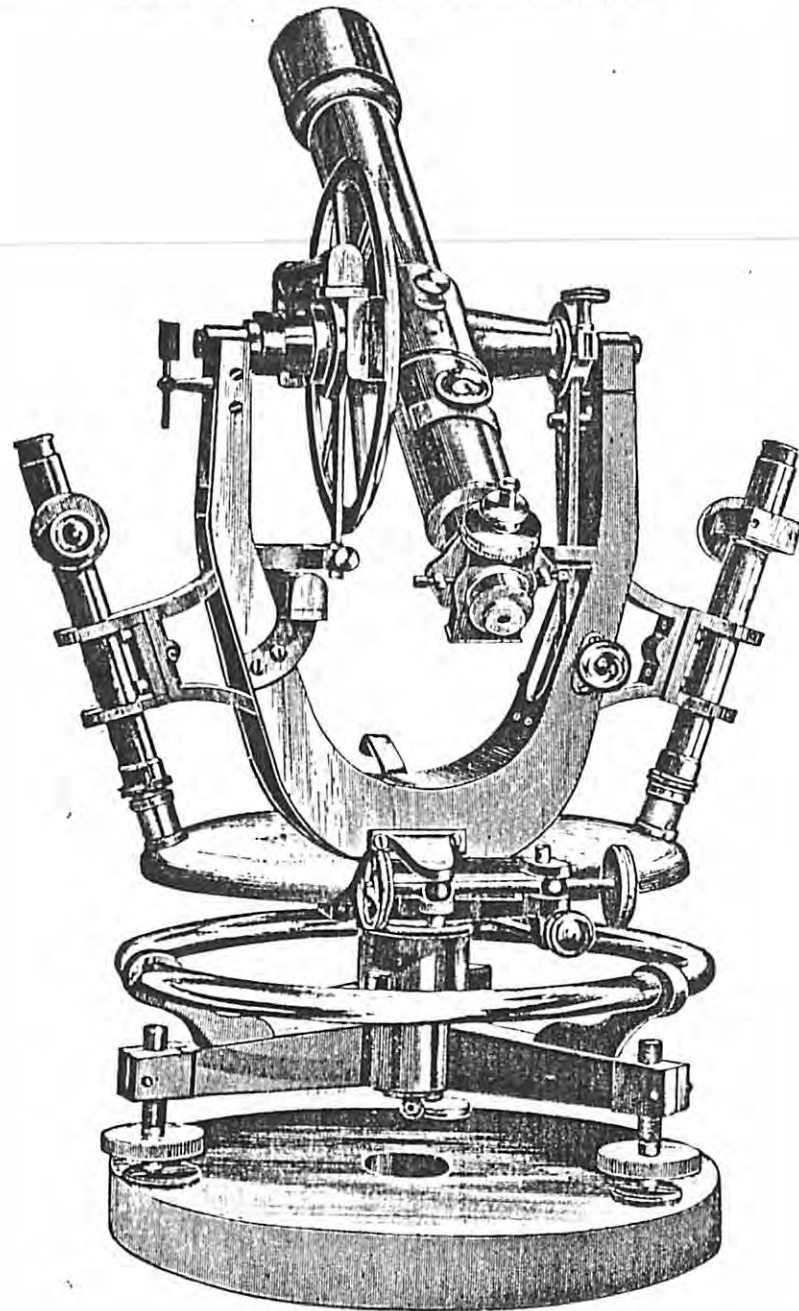

10-inch Altitude-Azimuth.

For triangulation and astronomical work. Horizontal circle reads to seconds by two micrometer-microscopes, every degree numbered; vertical circle to 20 seconds by vernier, sensitive striding-level, telescope 1 $\frac{3}{4}$ -inch aperture, field illumination with lamp and lamp stand, direct and diagonal eye-piece; packed in two boxes.

Price..... \$850 00

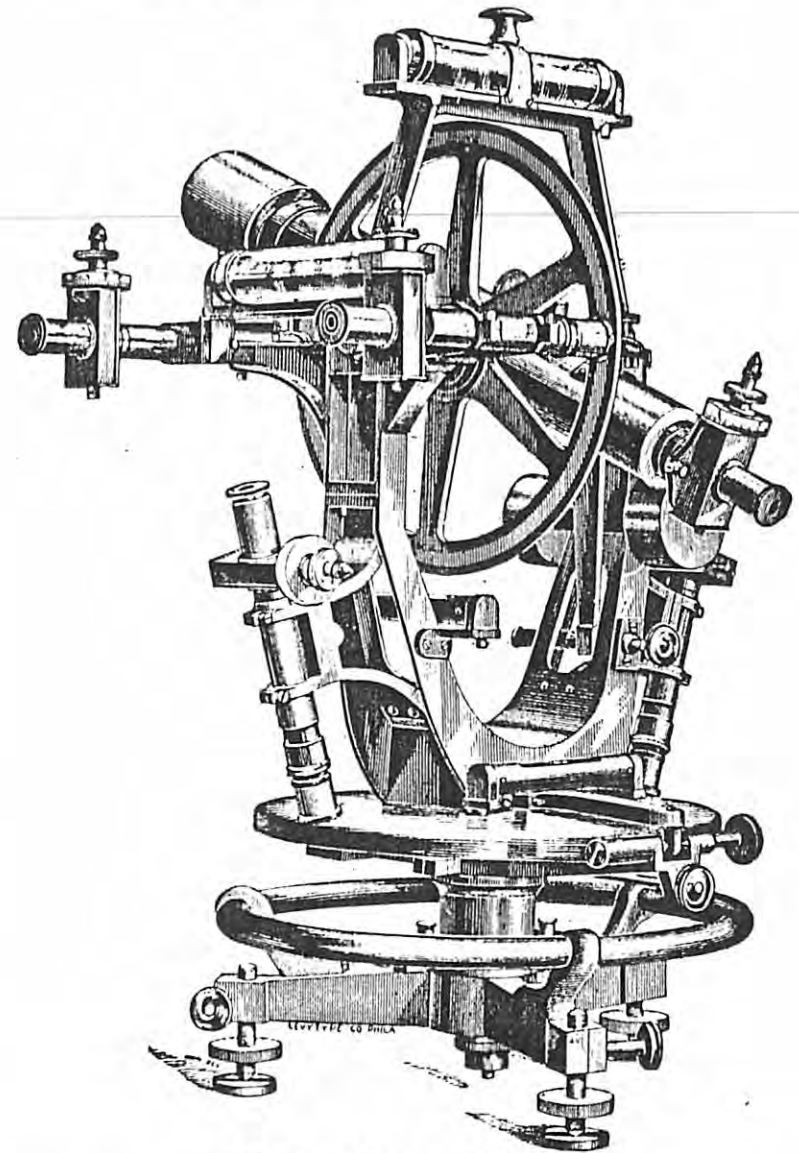

10-inch Altitude-Azimuth.

Same as the preceding, but also having a 10-inch vertical circle reading to seconds by micrometer-microscopes. Complete in two boxes.

Price..... \$1,050 00

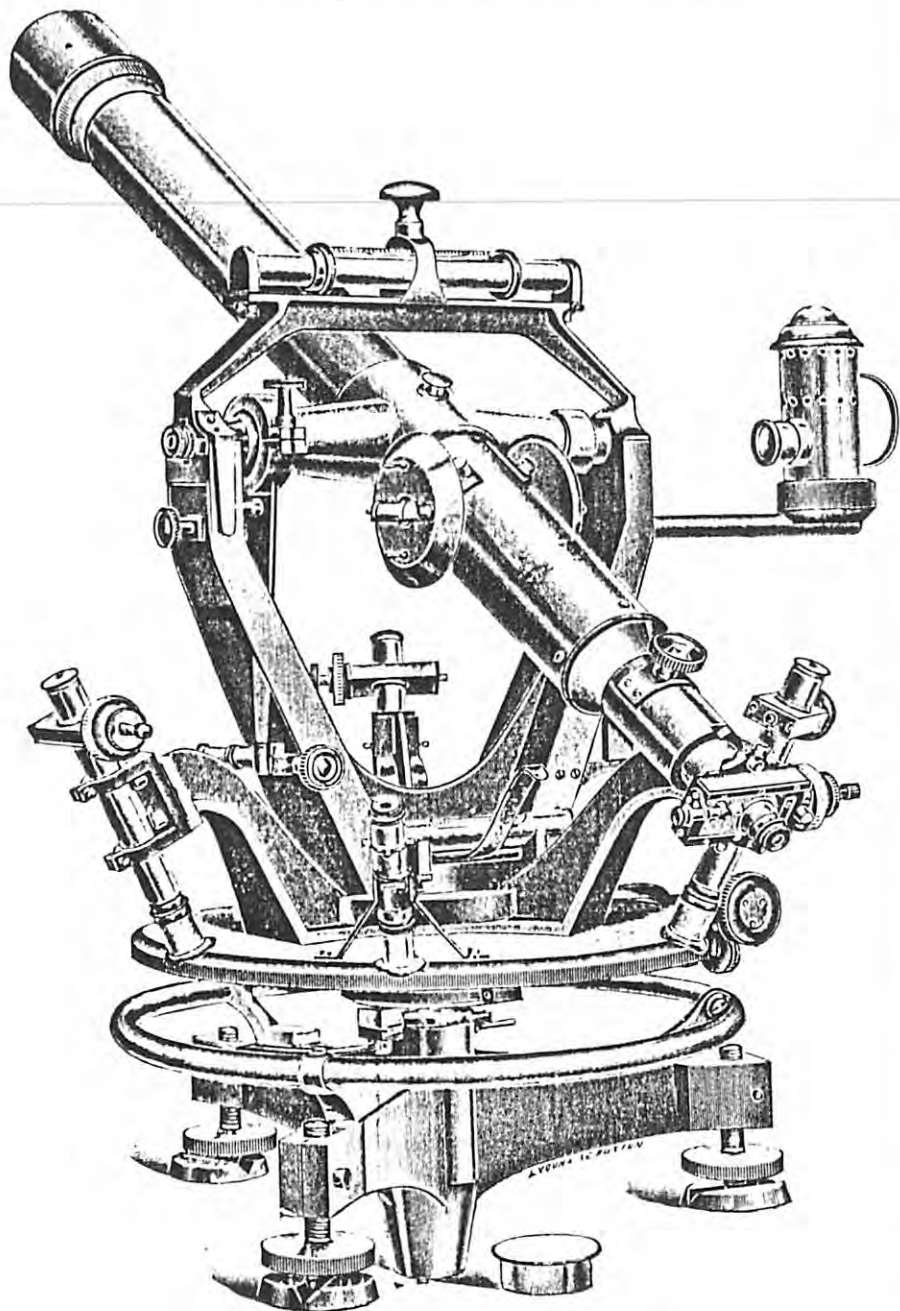

12-inch Coast Survey Theodolite.

Price..... \$1,200 00

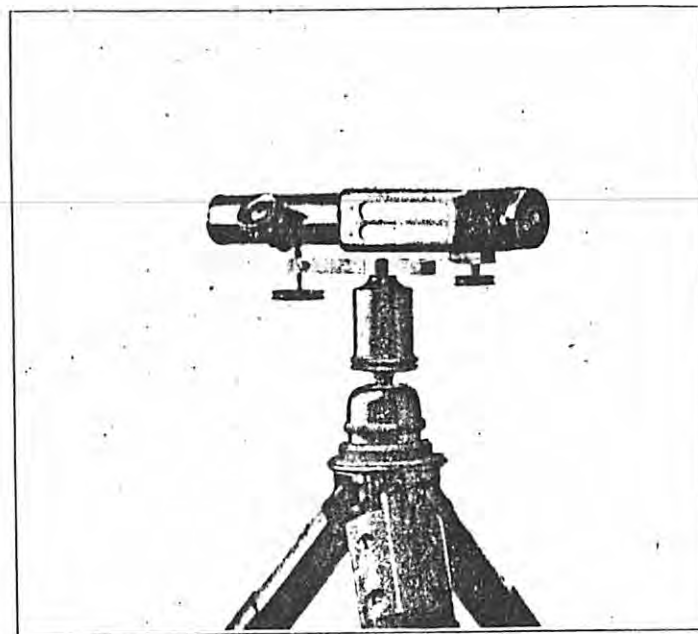

Pocket Hand Level (with reversing bubble).

The telescope of this instrument magnifies 12 diameters. Very close work can be done with it, especially when used with a tripod. The object to be sighted at and the level bubble appear in the field of view at the same time.

Price..... \$40 00
 Price with folding stand..... 50 00

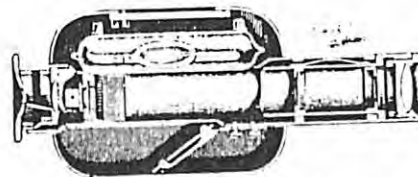

Showing Interior Construction.

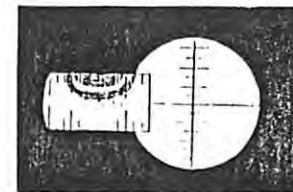

Field of View.

We have adopted this Level for use with a sextant as an artificial horizon. When so used it is mounted in a sleeve which screws into the place usually occupied by the observing telescope. In order to eliminate index error, the Level can be rotated 180° in the sleeve.

Price \$50 00

Wurdemann's Pivot Level.

This is one of the most accurate levelling instruments in use. The telescope rests in pivots, and can be elevated or depressed by a fine micrometer screw. The horizontality of the telescope is determined by the delicate level which rests on top of the telescope upon two rings of equal diameter. Both level and telescope can be reversed and the adjustments accurately made and verified. It is in fact an inverted Y Level.

This instrument is made in two sizes:

- 15-inch Telescope, power 30 diameters, price..... \$125 00
- 10-inch Telescope, power 20 diameters, price..... 90 00

These Levels are also made with 4 levelling screws and erecting eye-piece at same price.

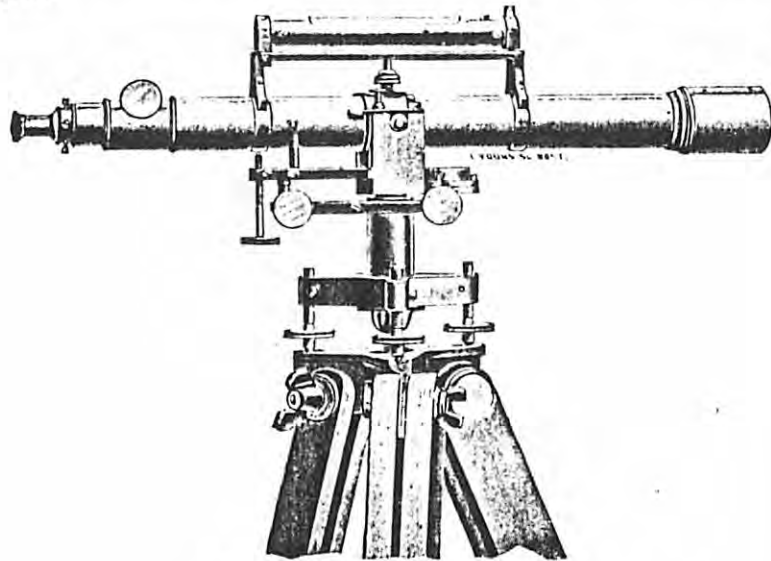

Wurdemann's Pivot Level.

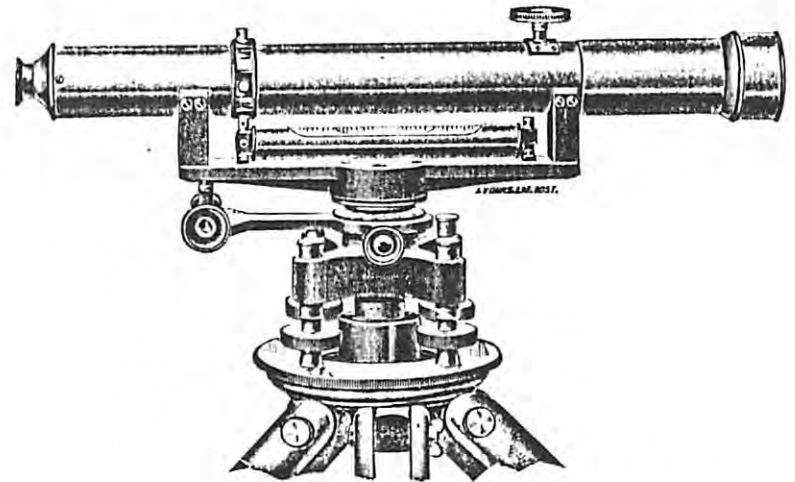

16-inch Dumpy Level.

These instruments are equal in every respect to the ordinary Y Level, and have the advantage of staying better in adjustment.

Price..... \$100 00

18-inch Engineer's Y Level.

The telescope has an aperture of 1 3/4 inches and magnifies 35 diameters. Erecting eye-piece with perfectly flat field. Improved arrangement to bring the cross-wire into exact focus. Protection to the object slide. Hard bell-metal rings and centres. Long sensitive level, graduated on the glass. Clamp and tangent attached to the levelling-bar under the eye-piece. The telescope is balanced when focused for mean distance. Abutting stops to set the wires horizontal and perpendicular.

The instrument does not detach from the levelling-head; it packs into the case erect. The case contains sun-shade, screw driver, and adjusting pins.

Weight of instrument about 11 pounds. Weight of tripod about 7 pounds.

Price..... \$140 00

Extras to Y Level.

Attachable mirror, to read the level from the eye end.....	\$10 00
Hardened steel centre.....	10 00
Fixed stadias (1 in 100).....	3 00
Gossamer cover.....	1 00

Reversion Levels.

Levels that are ground barrel-shape on the inside are called Reversion Levels. Although they have been for a long time in use in Europe, recent communications to Engineering Journals indicate that several makers claim to have invented them here.

These Levels serve the same purpose as two levels placed parallel on opposite sides of a telescope.

Notwithstanding the cross-wires may be out of adjustment and the collars of unequal diameter, still the mean of a double observation will give the true result.

The additional cost of such a level is \$20.

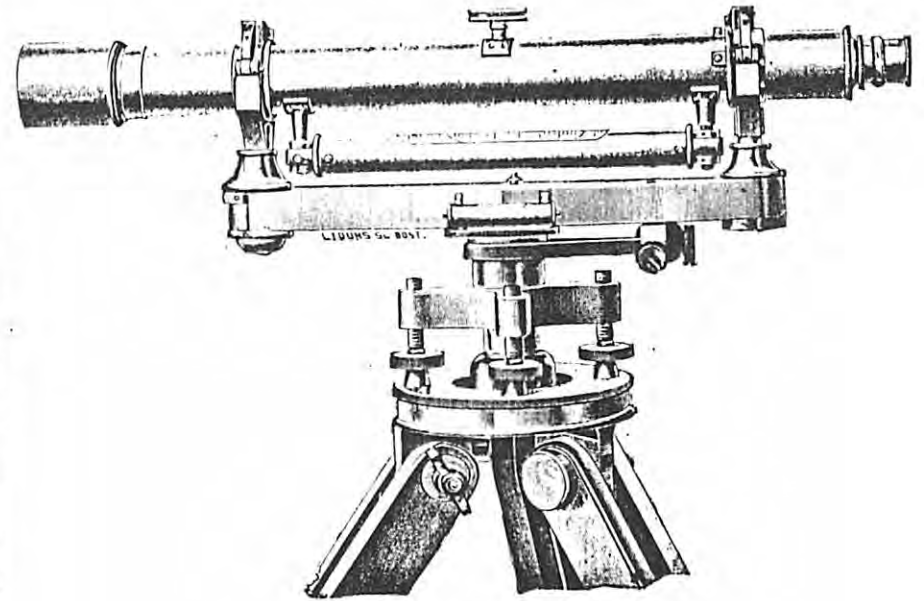

18-inch Engineer's Y Level.

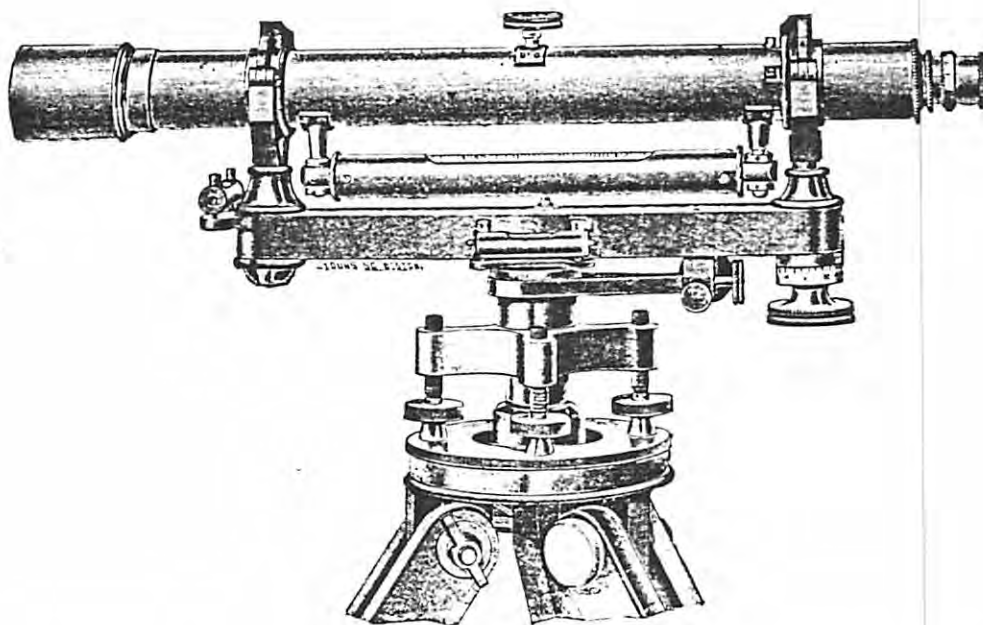

Precision Y Level.

Same as the preceding, but with one of the Y's movable by means of a graduated micrometer-screw. It is intended for very accurate work. Price \$180.00.

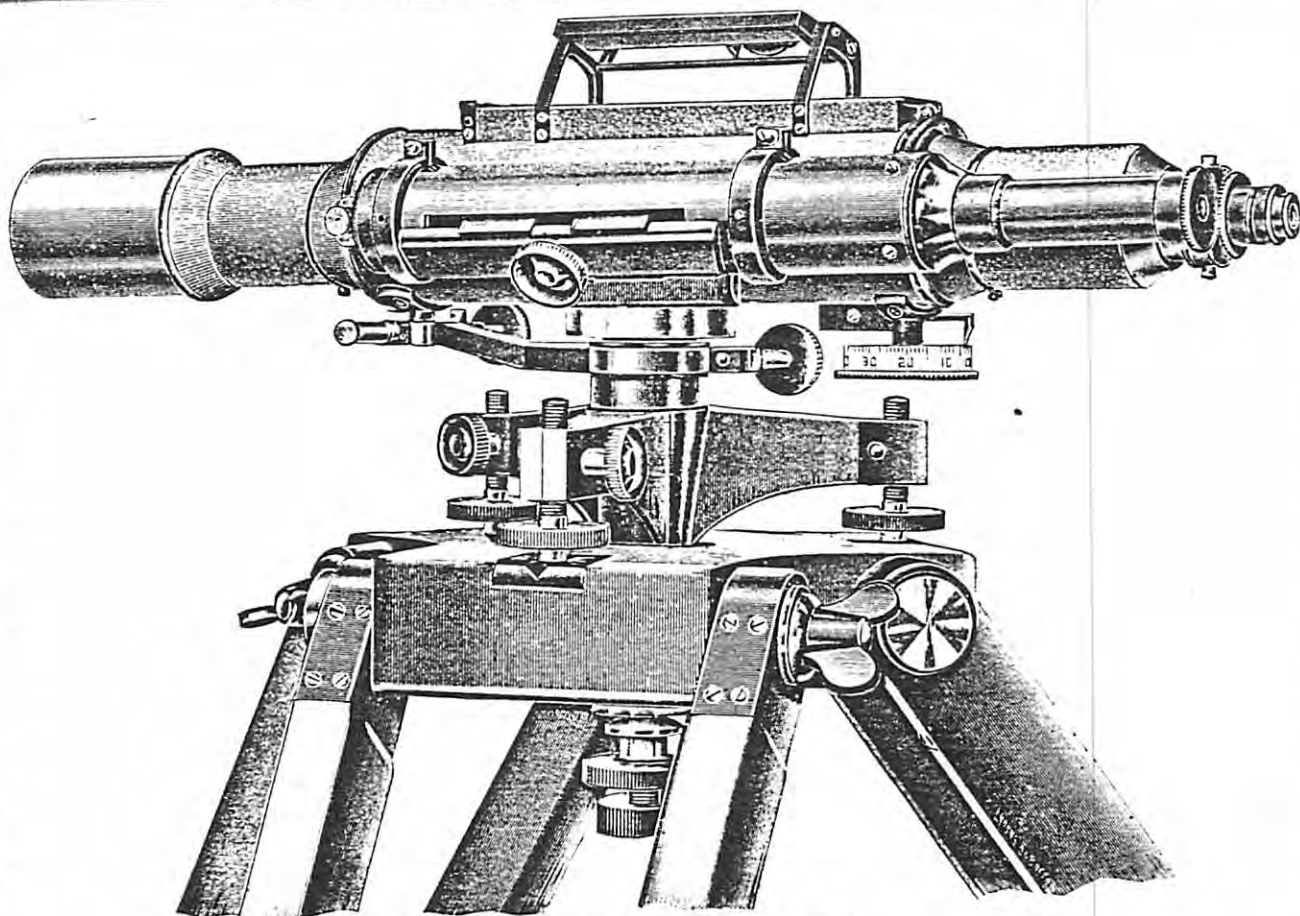

Coast Survey Precision Level.

The telescope tube is made of nickel steel, which has a very small coefficient of expansion. The Level is read from the eye end without the observer being obliged to move. The telescope has an aperture of 1 1/2 inches. The Level, which is chambered, has a value of 3 seconds per division.

Completely packed, with tripod..... \$300 00

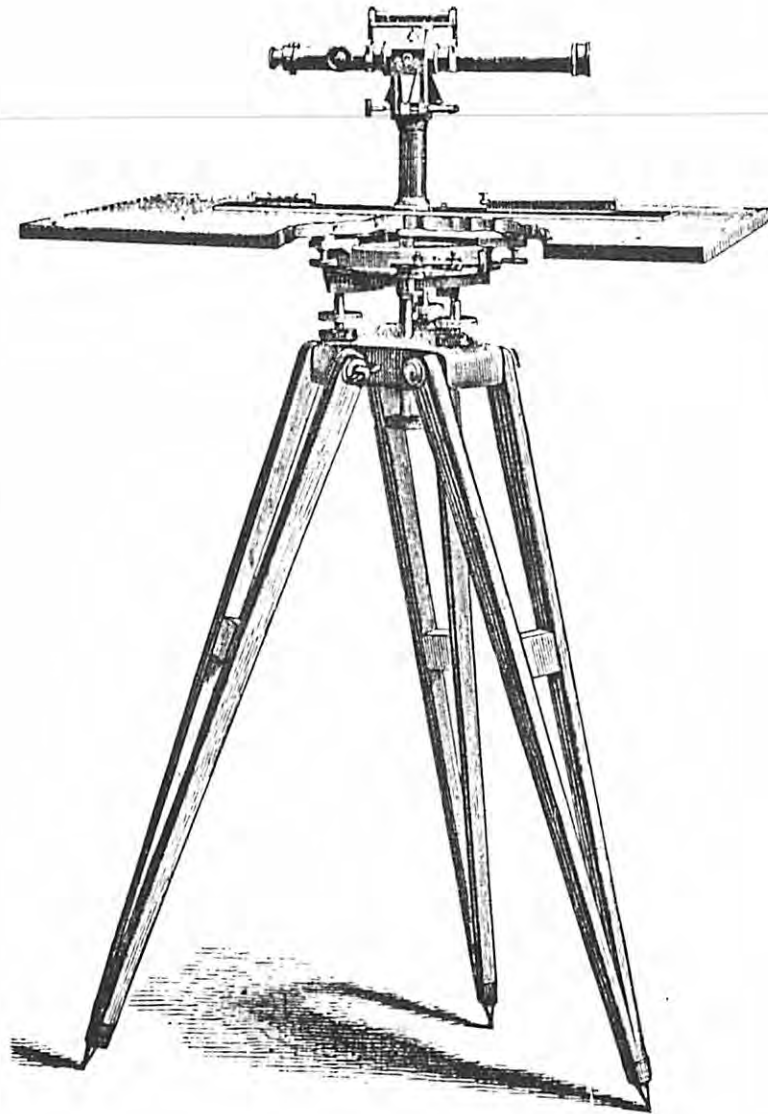
PLANE-TABLE.

The above cut represents one of our Plane-Tables with a portion of the board cut out to show the motion-work. It is the most simple and effective form of Plane-Table made. The bearing surface of the motion-work being 8 inches in

diameter, the table, when clamped, is perfectly firm. The alidade rule is 20 inches in length, and carries a powerful telescope of $1\frac{1}{4}$ inches aperture and 15 inches focus. For easier adjustment of collimation the telescope can be turned in its axis 180° . The compass-box is detachable; needle 5 inches long; striding-level reading to minutes. Stadia lines for measuring distances, besides the ordinary cross-line, are ruled on glass diaphragm. The vertical arc reads to minutes. The board is 24 by 30 inches and is packed in an extra box. The alidade is in a box with a number of paper clamps, besides the usual accessories; the motion-work also in a separate box.

Price, complete, with firm tripod stand..... \$275 00

PLANE TABLE (U. S. Geological Survey Pattern).

The Alidade has a very powerful telescope of 12 inches focus, $1\frac{1}{2}$ -inch diameter graduation on arc on edge, and can be read from eye-end, striding level over telescope.

Price..... \$95 00

Plane Table Movement for the above (as devised by Johnson), with stiff tripod and board 30 x 24, with compass, packed complete... \$95 00

SEXTANT.

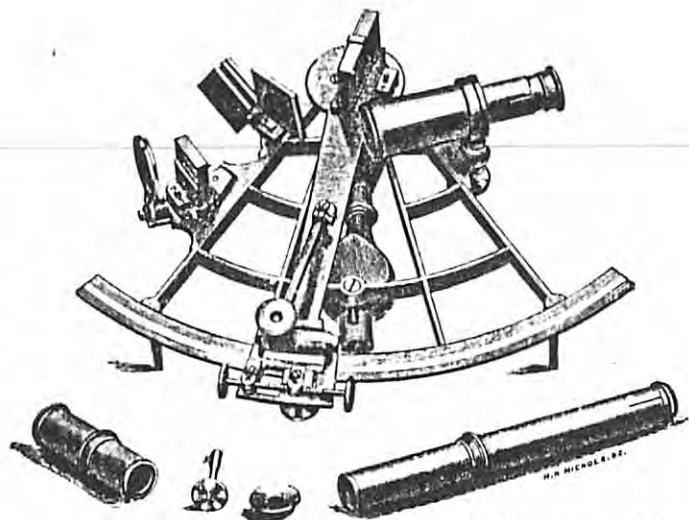

The above cut represents our style of Sextant, which, although very light, is an exceedingly accurate instrument.

Sextant of 7½ inches radius, divided on silver, and reading to ten seconds. The cut shows all accessories.

In box complete..... \$130 00

ARTIFICIAL HORIZON.

Artificial Horizon, with mercury bottle and trough, rectangular plate-glass cover, packed in mahogany box..... \$30 00

POCKET COMPASS.



Prismatic Compass, 3 inches diameter, with divided ring on needle and folding sights; packed in neat case, very convenient for reconnoissance..... \$35 00

U. S. Geological Survey Clinometer Compass..... \$25 00

HELIOTROPES.

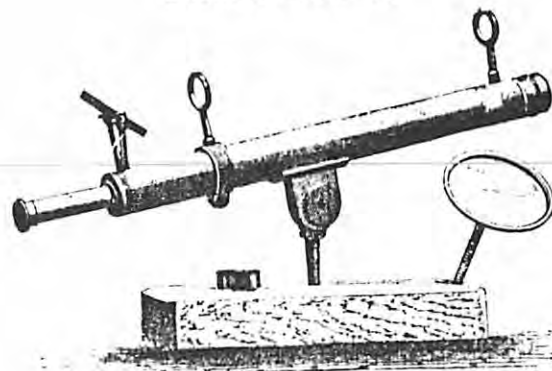

Wurdemann's Heliotrope.

The telescope body is a heavy brass tube; in the middle is a wood screw with joint for attaching the instrument to a tree or post. Mirrors of plate glass. Price, in box..... \$35 00

Heliotrope, on tripod, with horizontal and vertical axis; with graduated circle for reading angles. Price, boxed..... \$75 00

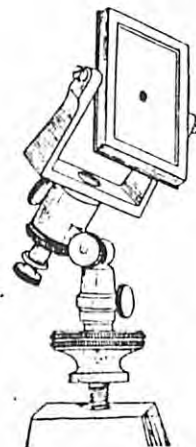

Pocket heliotrope, Steinheil's; a beautiful instrument that requires no adjustment.

In case..... \$35 00

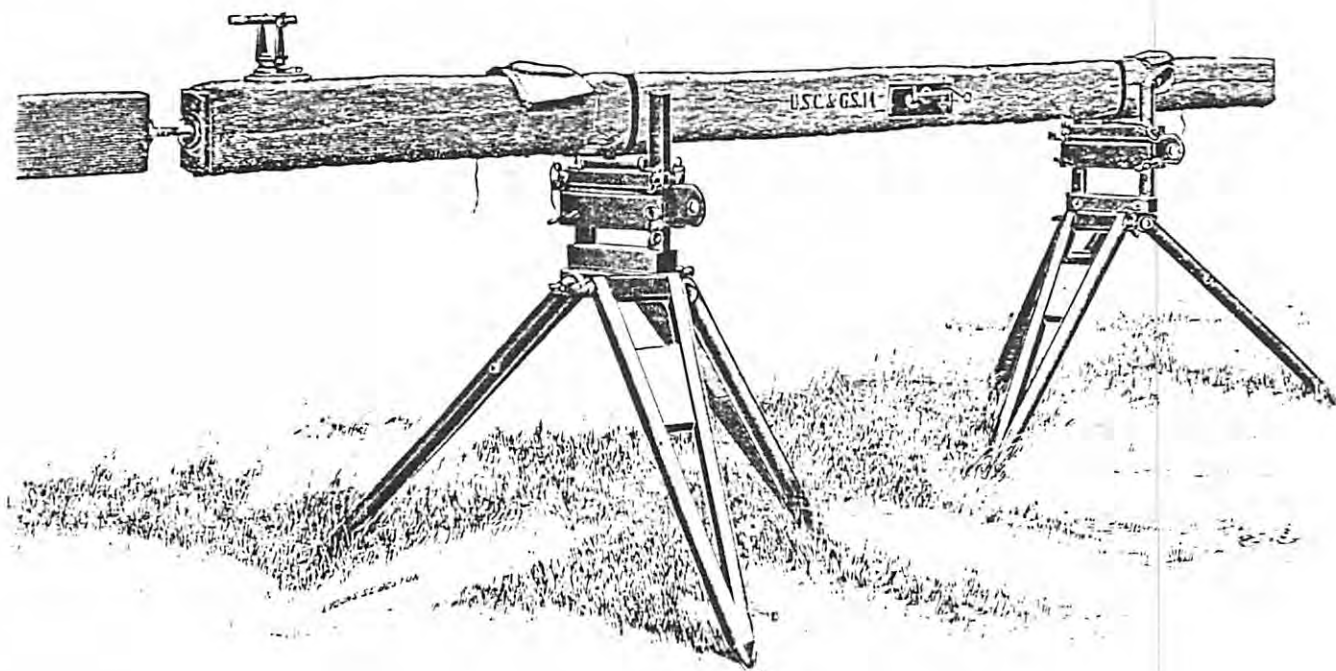

Improved Coast Survey Base Apparatus.

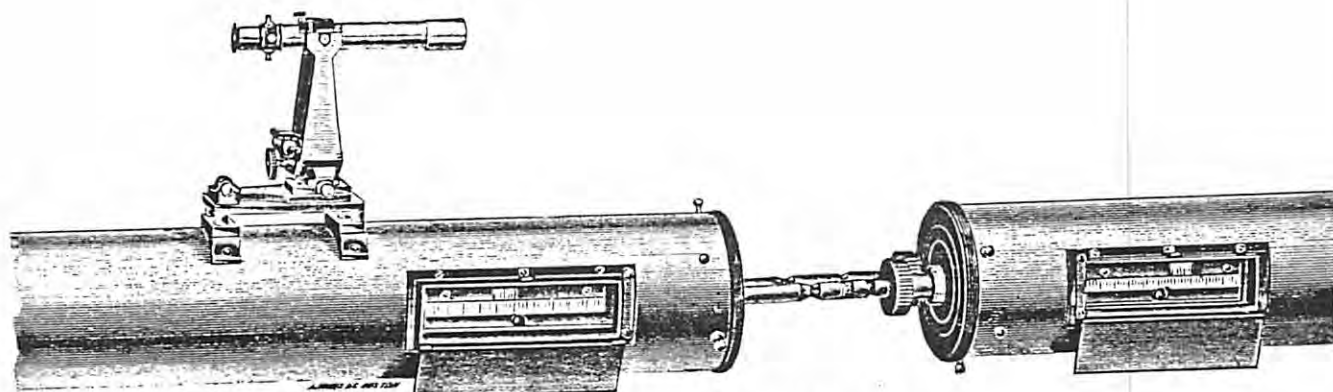

Improved Coast Survey Base Apparatus.

For description of this Apparatus, see United States Coast and Geodetic Survey Report for 1892.

ZENITH INSTRUMENTS.

The following cut represents the most improved form of Zenith Telescopes. The telescope swings on a horizontal axis, which is fastened to a vertical axis, and can therefore be moved into any position. It is especially adapted for the determination of differences of zenith distances. Graduated horizontal circle with clamp and tangent. The telescope, of 3-in. aperture, carries a circle with the fine latitude level, and is provided with a micrometer eye-piece.

The Zenith Telescope depicted opposite has an objective of 6 inches clear aperture and about 30 inches focus and was made for the Georgetown College Observatory, and is chiefly used for photographic determinations of latitude. This instrument is the largest of its kind and is doing excellent work.

We constructed this instrument in 1893, and it has since been copied by other makers, even to the smallest details.

Price with 3-inch Telescope \$1,000 00

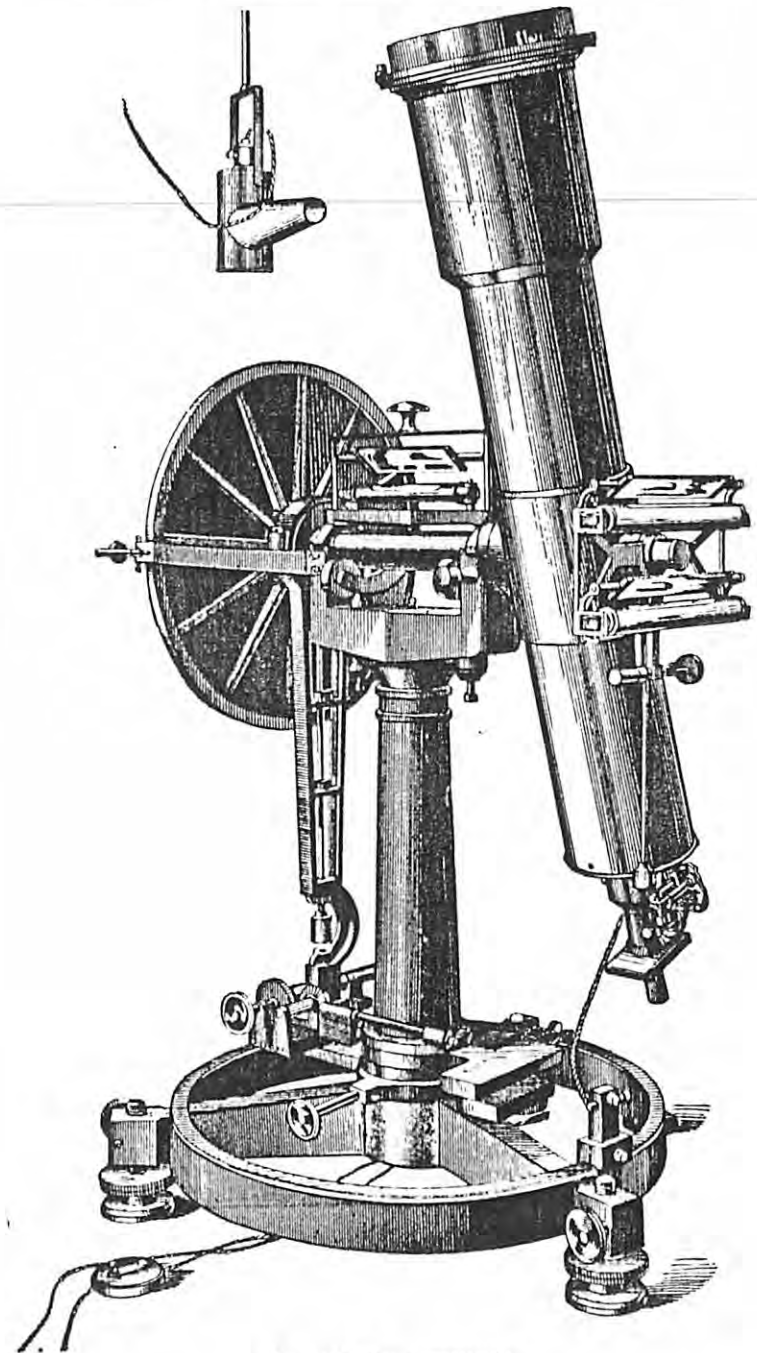

Zenith Instrument.

NEW COMBINATION TRANSIT AND ZENITH TELESCOPE.

This instrument possesses several advantages over older forms. The base is circular, and the upper part moves smoothly upon the lower without disturbing the azimuth; this latter is provided with a graduation.

The instrument is provided with a reversing apparatus, and can be manipulated with the greatest ease. It is very rigidly built, although the entire instrument weighs less than 100 pounds. Telescope 3 inches aperture, striding and latitude levels reading to single seconds, eye-piece micrometer, with diagonal eye-piece and swivel adapter, packed in two boxes.

Price.....\$1,200 00

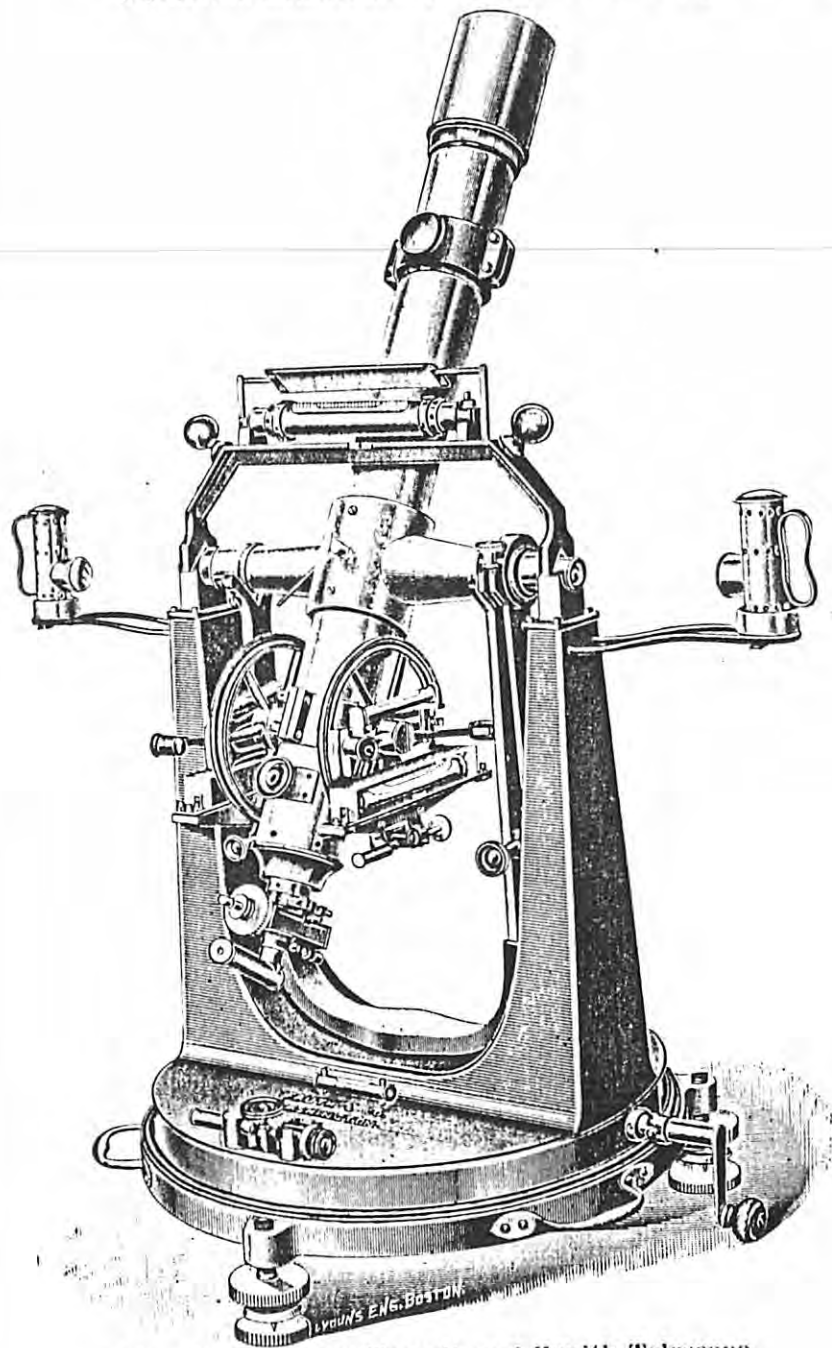

New Combination Transit and Zenith Telescope.

UNIVERSAL INSTRUMENT.

This instrument is especially adapted for the determination of time and latitude, and possesses several features which make it a very accurate and convenient instrument. It is almost entirely made of steel, the wearing parts hardened, and while it is of such weight that it can easily be carried about—the entire instrument weighing only about 90 pounds—it is, on account of material used, and its construction, extremely rigid, and once adjusted will stay so for a long time.

For double Zenith distance work it can readily be revolved 180°, and stops are provided for that purpose, as well as a graduated circle. It can be reversed by means of the reversing apparatus, and the Striding Level need never be taken off. The pivots—being glass hard—are measured once for all, and the Level need not be reversed.

The micrometer eye-piece can be taken off and a photographic plate-holder substituted. Instead of bisecting the star image visually, the photographic trails of both N. & S. stars are measured, and for this purpose the micrometer is attached to a microscope with which the measures are taken. The great advantage of this method consists in reading the fine latitude Levels—two are provided—at the exact time of the star's transit, while in the visual method the Levels are read *before* or *after* the observation is made. The great interest which is now taken in latitude work has prompted us to construct this instrument.

Rev. J. G. Hagen, S. J., Director of the Georgetown College Observatory, has tested this instrument, and says:

* * * "Although we have had only one night in which to work in, and we were not yet accustomed to the new instrument, we obtained excellent results and determined our latitude successfully. The results are extremely satisfactory and show that the photographic method is in many respects superior to the visual."

Price of Universal Instrument with 3-inch telescope..... \$1,600 00

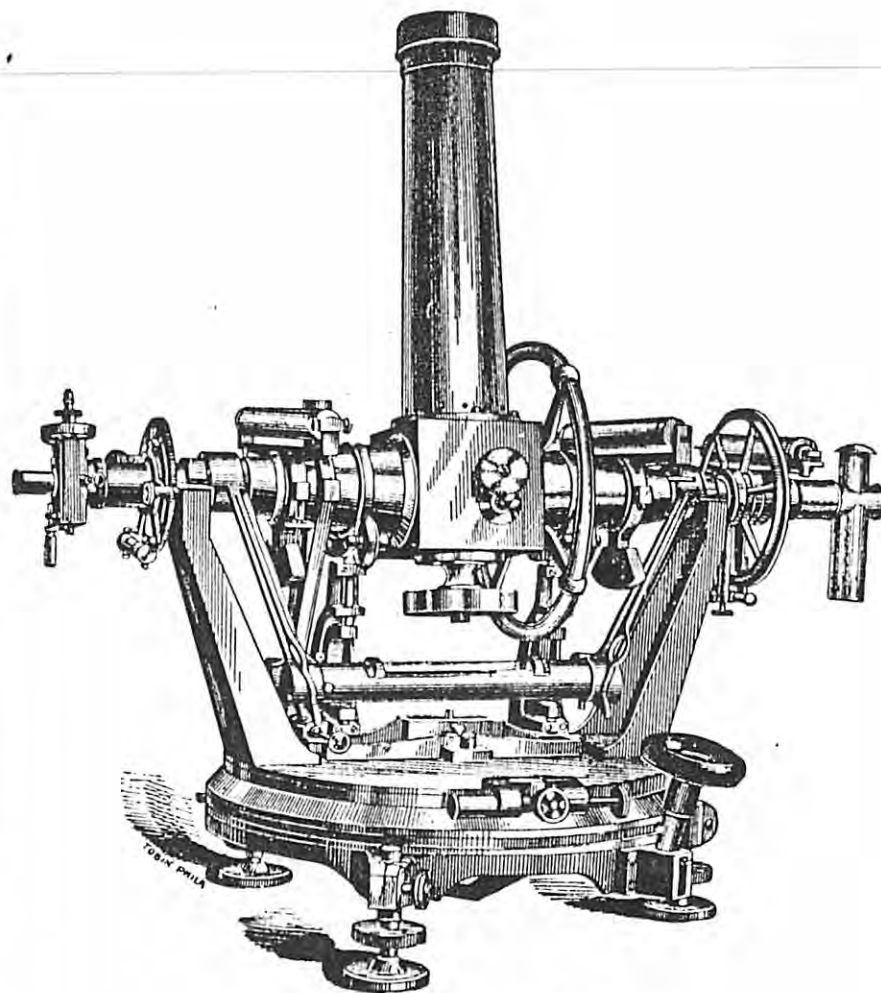

Universal Instrument.

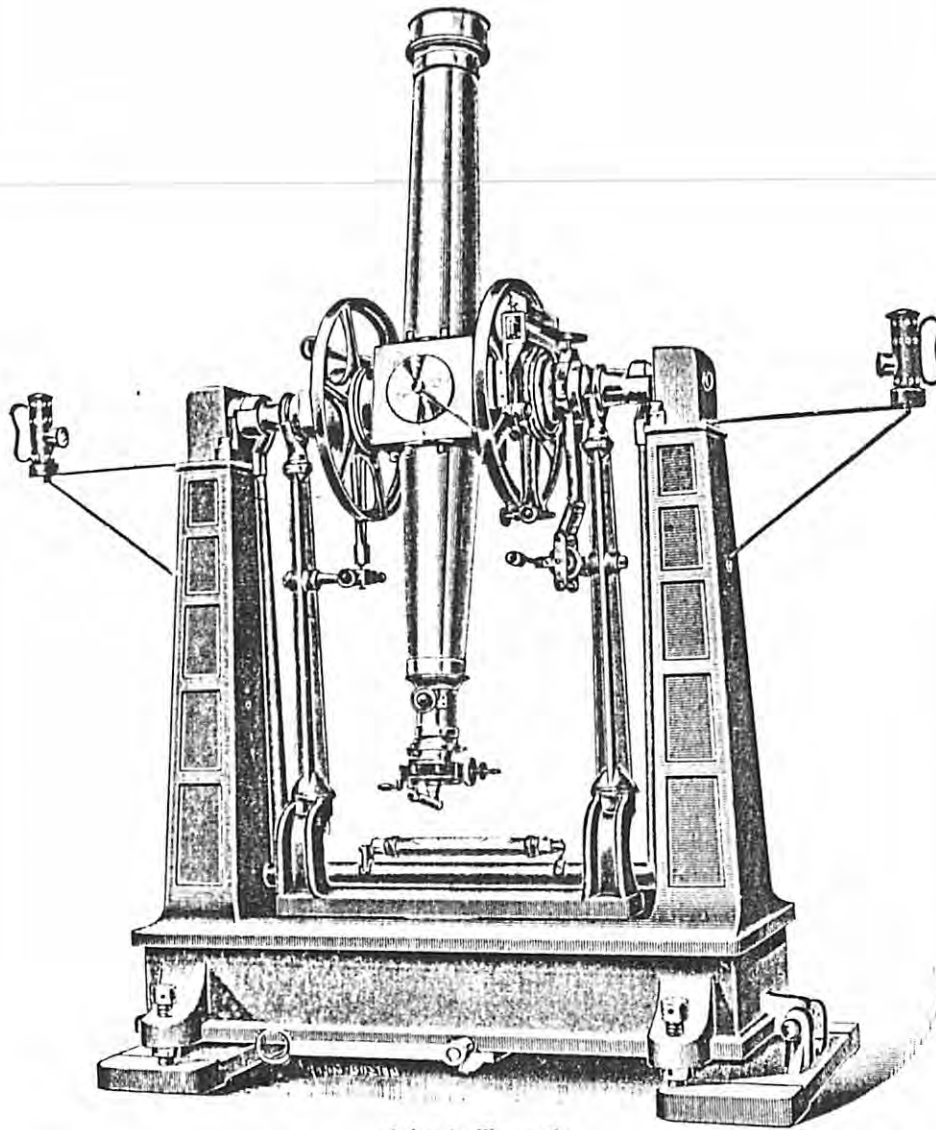

3-inch Transit.

Transit Instrument, of 3 inches aperture, about $3\frac{1}{2}$ feet focus. The axis carries two 12-inch circles, one reading to 10 seconds, the other to minutes, both divided on the edge. The fine circle carries the latitude level. The hanging level is entirely free and stays on during reversal. The counterpoises hang on the inside of the pillars. The iron stand has the necessary adjustments for

altitude and azimuth. Reversing apparatus, mercurial basin, diagonal, direct, and collimating eye-pieces, lamps, etc.

Price\$1,200 00

The same, with 6-inch setting circle, and level alidade on axis; delicate striding level; glass micrometer instead of spider-lines; direct and diagonal eye-piece, improved clamp. One of the Y's can be moved in azimuth, the other in altitude, and there be firmly clamped.

Reversing apparatus, lamps, etc..... 790 00

The same, with 2-inch telescope, without reversing apparatus..... 500 00

"Outfit" Transit. This is the cheapest Transit we make; it has a telescope of nearly 2-inch aperture with a good objective (not of the first quality), bell-metal pivots; 1 division of striding level equals about 3 seconds; small silvered finding circle, glass reticle, and prism. There is no diagonal eye-piece, and the whole instrument is made as simple as possible in order to keep the price low. Nevertheless it is a very good instrument for time observation.

Price..... 175 00

SMALL MERIDIAN CIRCLE.

This instrument takes the place of our old 3-inch Meridian Circle. It is built entirely of cast-iron and steel, greatly improved in design, as a glance at the cut will show, and is in fact a new instrument. As the graduations which we are enabled to produce now are of such excellence we had to use a larger telescope in order to make its pointing power equal to the accuracy of the graduation. With a clear aperture of $4\frac{1}{2}$ inches we claim that fundamental work can be done with this instrument, although it is of the semi-portable kind, being complete in itself and ready to be set up on a pier. By placing the circles near the telescope we are enabled to lift it by merely giving the handle at the base one half turn; the telescope can then be turned end for end, and a reverse turn of the handle brings it down into its bearings: it takes less than a quarter of a minute to reverse the telescope. The microscope-holders are circular, allowing the microscope to be placed into any position; the counterpoise weights hang on the inside of the pillars. One of the circles is divided on silver into 5-minute spaces, every degree being numbered, and the other has a coarse graduation for finding purposes at the edge. The level hangs entirely free, and is more convenient and more certain in its action than a striding-level would be. The iron stand is provided with the necessary adjusting screws for movement in altitude and azimuth.

Price of instrument, with 4-inch telescope, $16\frac{1}{2}$ -inch circles, sensitive striding-level, diagonal, direct and collimating eye-piece, mercury basin, 2 lamps.....\$1,850 00

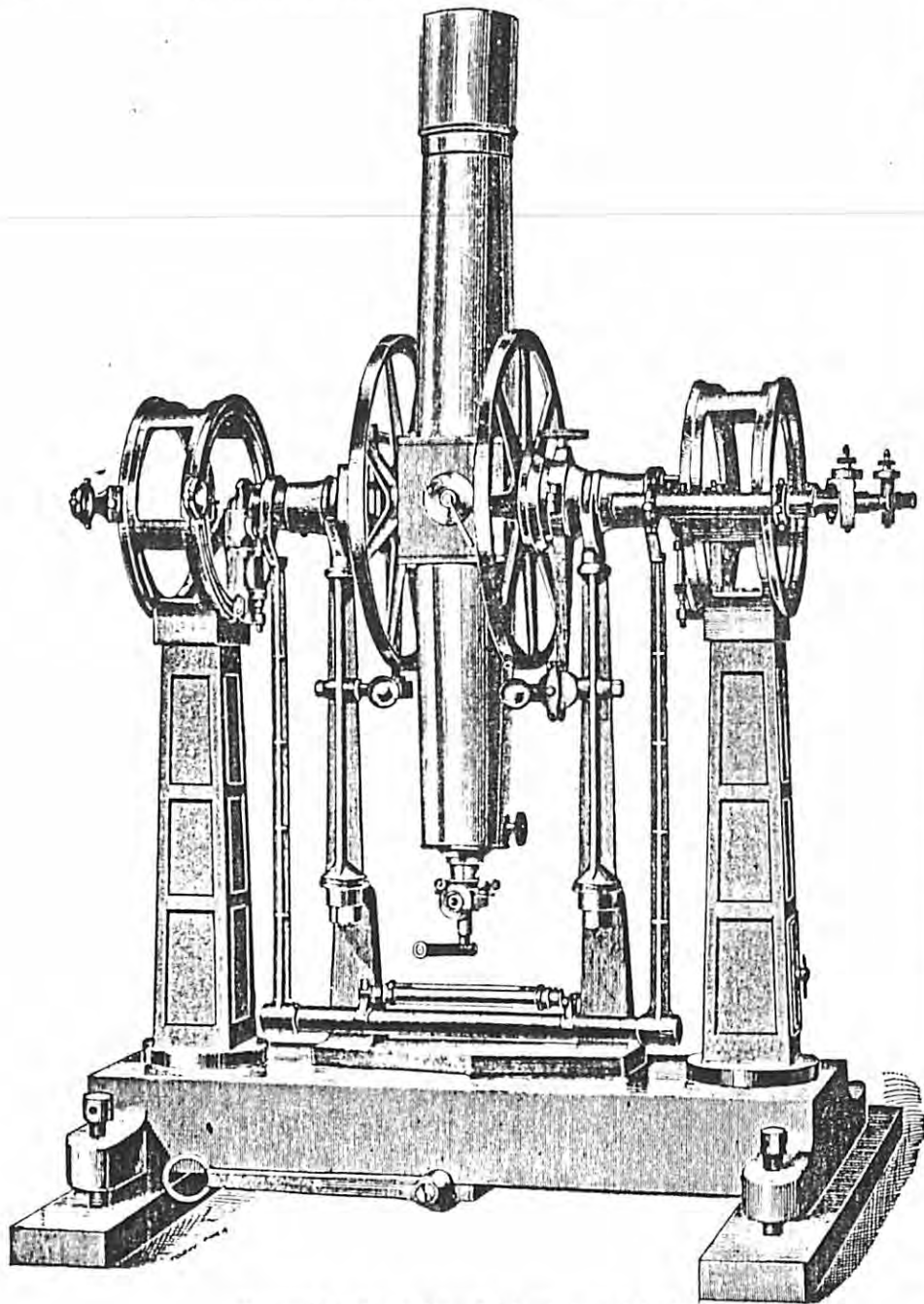

4- and 5-inch Steel Meridian Circle.

FIXED MERIDIAN CIRCLES.

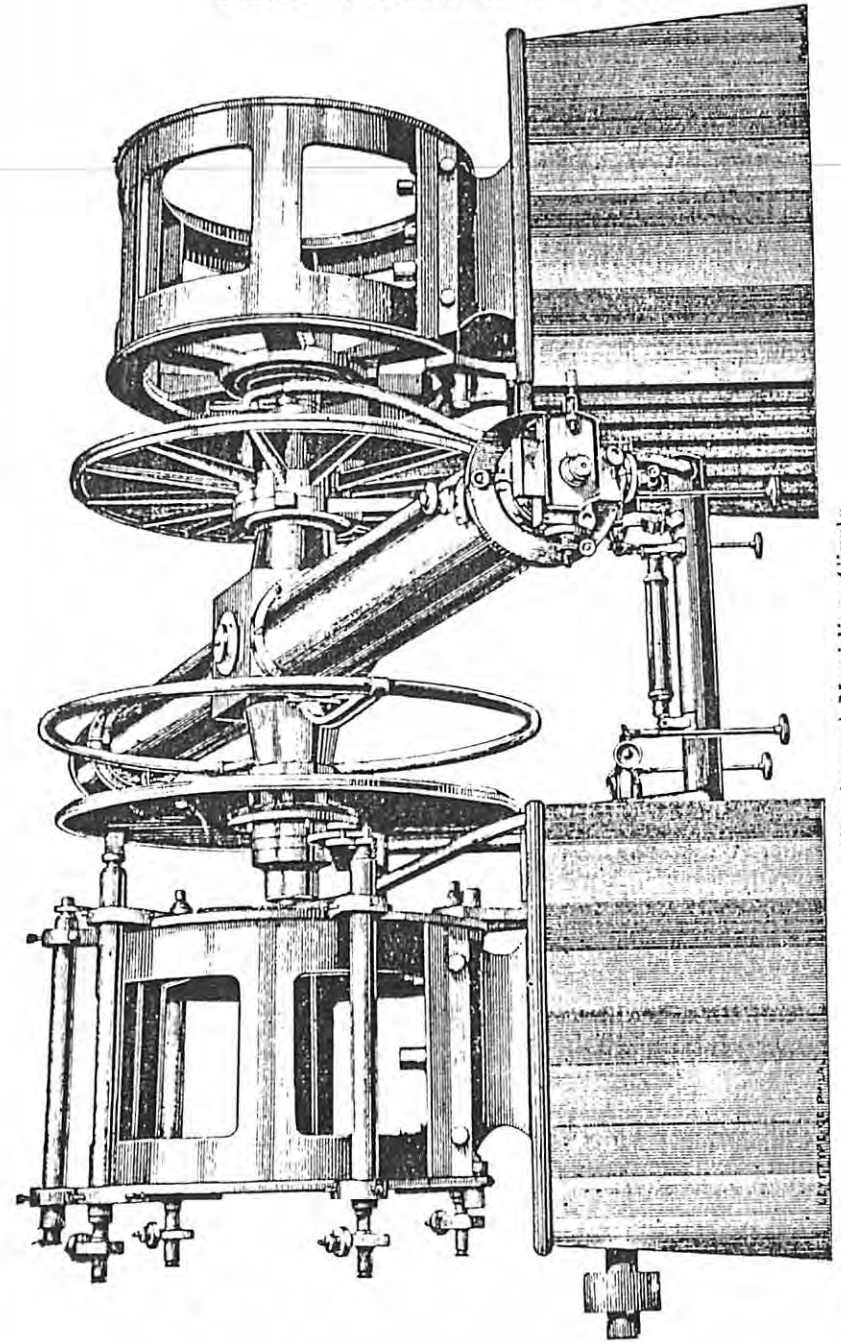

Cincinnati Meridian Circle.

The preceding cut represents a Meridian Circle of the first class as made for the Cincinnati observatory.

In our latest form of Meridian Circles and large Transits the counterpoising and reversing apparatus is concealed below the floor and is fixed there. The piers are thus relieved of all load, excepting the few pounds with which the telescope is resting in the Y's, and as the counterpoise is arranged exactly like a scale-beam resting on hardened knife-edges, its action is at once decisive and delicate, and insures the certainty that both pivots rest with the same weight on each Y. During reversal the counterpoises take care of themselves, and the piers remain absolutely undisturbed, as there is no weight taken off.

In order to reverse the instrument end for end it is only necessary to turn the handle at the west pier until it comes to a dead stop. The instrument has then been lifted, turned 180° , and been lowered again into its bearings. Less than half a minute is required for this operation.

Any one who has worked with the old style reversing wagons will appreciate our improvement. There is absolutely no danger of injury to the instrument during reversal. The operation can be performed in the dark, and it takes but very little time to do it. By an ingenious arrangement the Level can be read by means of a small telescope in a very comfortable position.

Wherever it was possible we have simplified the instrument, and have constructed it with a view to the use of steel throughout. The instrument is lighter, stronger than if made of brass, and there is but little polish about it.

CINCINNATI OBSERVATORY, April 12, 1898.

DEAR MR. SAEGMULLER:

The five-inch meridian circle constructed by Fauth & Co. for the Cincinnati Observatory has now been in constant use for nearly ten years, and has proved to be a most satisfactory instrument in all respects. It is simple in construction and very convenient in manipulation. One person can readily reverse it in less than five minutes. The accuracy of the circle is certainly remarkable. Though it is only two feet in diameter, yet so far as investigation has been made the errors of division seldom amount to a second of arc.

In our determinations of declination no corrections for division errors are applied, but they are to a large extent eliminated by shifting the circle each year and observing the same stars on different divisions. The probable error of a single determination of declination in the work of the last five years is only $0''.4$, which, of course, includes both division errors and accidental errors of observation. We are then, I think, justified in the belief that the tedious investigation of division errors is no longer necessary, and that we can rely to a greater extent than formerly on the skill of our mechanics.

After having made nearly 20,000 observations with our instruments, I am unable to suggest any material improvement.

J. G. PORTER.

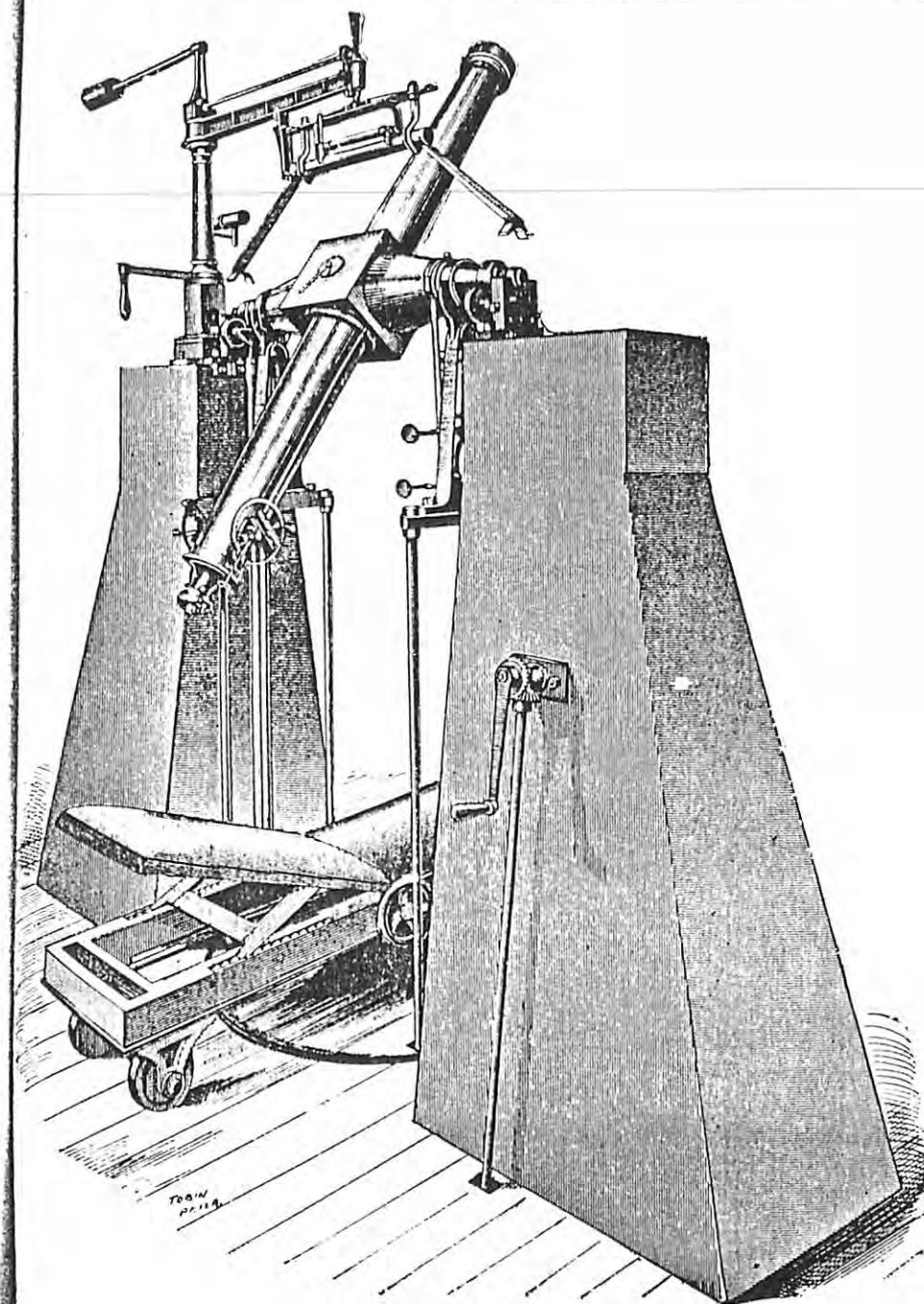

Prime Vertical Transit.

7

2

Large E.P. Equivalent focal length = 1"
Mag. Power with 20" O.F. = $20 \frac{\text{dia}}{\text{in}}$

Small E.P. Equiv. " length = 0.6"
Mag. Power with 20" O.F. = 33.3

This is about as near as can
be measured & calculated & is
sufficiently near for practical purposes.
J. N. Sidle

PRIME VERTICAL TRANSIT

As Built by us for the New Naval Observatory.

This instrument is mounted in such a manner that the counterpoising and reversing apparatus are concealed below the floor and are fixed there. The piers are thus relieved of all load, excepting the few pounds with which the telescope is resting in its bearings, and as the counterpoise is arranged exactly like a scale beam resting on hardened knife edges, its action is at once decisive and delicate, and insures the certainty that both pivots rest with the same weight on each Y. During the reversal the counterpoises take care of themselves, and the piers remain absolutely undisturbed, as there is no weight taken off.

In order to reverse the instrument end for end it is only necessary to turn the handle on the south pier until it comes to a stop. The instrument has then been lifted, turned 180°, and been lowered again into its bearings. This can be done in less than twenty seconds; it can be done in the dark, and there is no danger of injuring the instrument.

The Striding Level can be reversed without handling it, by merely turning a crank on the north pier. The reading of the Level is accomplished by means of a small telescope.

This instrument has been in use now for over 7 years at the new Naval Observatory and is doing excellent work.

We have made a similar instrument for the Observatory of Georgetown University, having a clear aperture of 9 inches, intended only for photographic work. It is fitted with the same kind of reversing apparatus and is one of the most complete instruments of its kind.

CHRONOGRAPHS.

The opposite cut represents our style of Chronograph, which, for compactness and regularity of action, cannot be surpassed. It is noiseless, and the governor regulates the speed so perfectly that the second marks form an accurate straight line. The cylinder is 14 inches long, 7½ inches diameter, so that one second is exactly 10 mm. long. An ordinary meter scale will answer to read the sheets with.

The clock-work is provided with maintaining power, which permits winding up without retarding motion; it is strong enough to drive several cylinders, which can readily be attached. The speed of the cylinder can be doubled so as to turn once in 30 seconds, which is especially convenient in exchanging clock signals in longitude work.

Price, with fountain pen and 100 sheets of paper and reading scale. . \$355 00

NOTE.—Our Chronographs are not provided with electric control. It is not only entirely unnecessary, but its use absolutely wrong in connection with a Chronograph. The case is entirely different with driving-clocks for equatorials.

“Outfit” Chronograph, barrel 7 inches long, 4 inches diameter; one second is thus a little more than 5 mm. A nice little instrument, plenty good enough for ordinary time observation.

Price..... \$150 00

NOTE.—This price includes nothing but the Chronograph, with the weights.

Three-Pen Chronograph (page 85), for physical research, driven by spring motor..... \$600 00

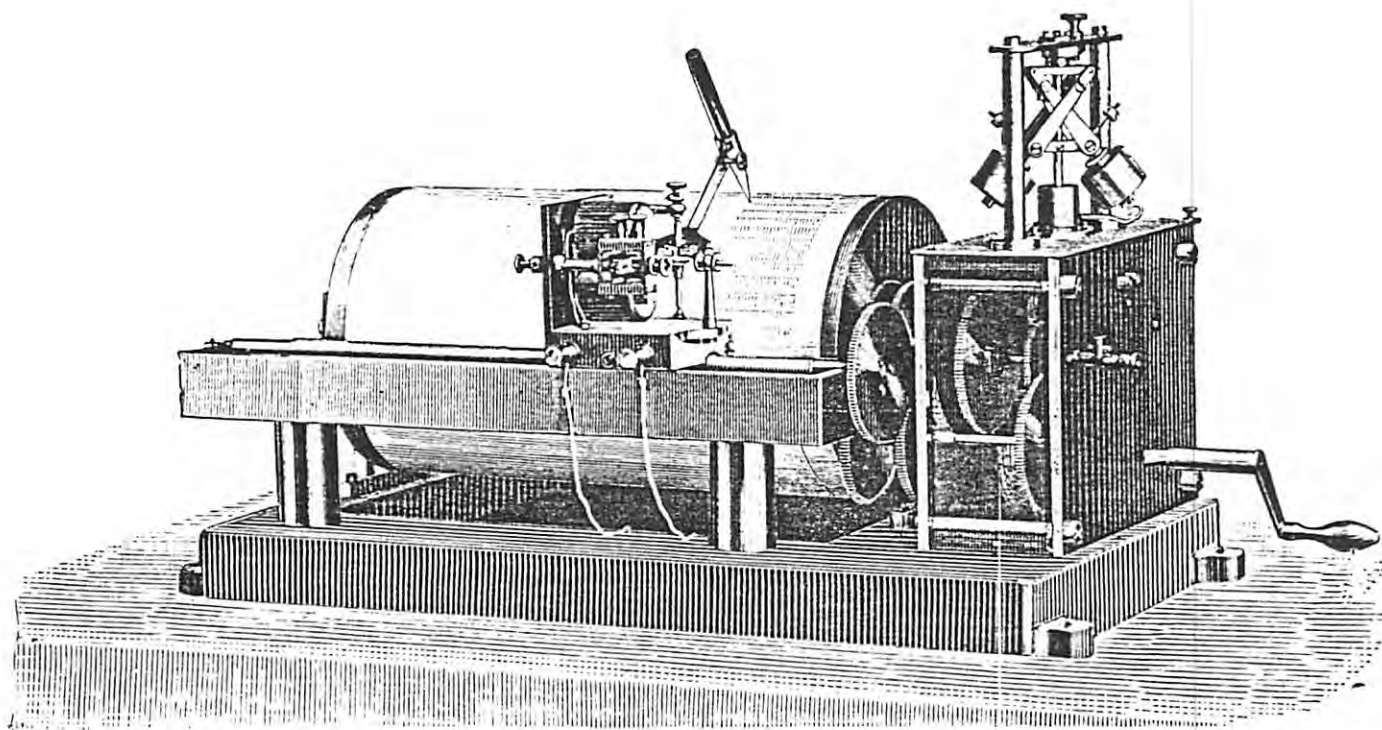

Chronograph.

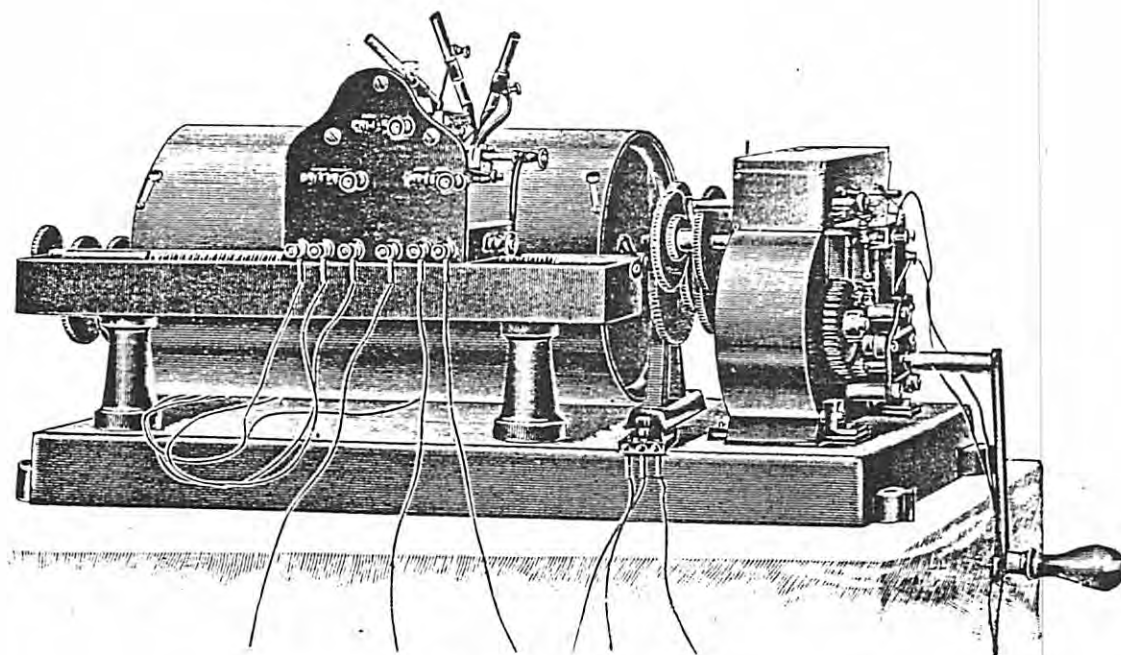

3-Pen Chronograph.

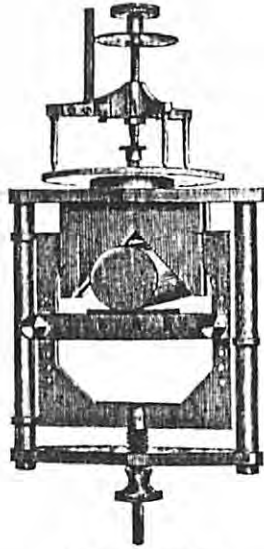

Spherometer.

A beautiful and exceedingly accurate instrument for measuring the inequality of pivots; much more reliable and expeditious than the contact level. As made by us, it will measure pivots from $2\frac{1}{2}$ inches down to the smallest size. The glass disc on which the three legs rest is perfectly flat; the screw is made with the utmost exactness, bearing on a jewelled centre, and the nut is so constructed that there can be no dead motion.

Price, as shown in cut, in box..... \$60 00

COLLIMATORS.

All sizes, horizontal and vertical, with telescopes from 2 to 6 inches aperture.

PHOTO-CHRONOGRAPH.

Photo-Chronograph (see pages 28-29), price..... \$100 00

ASTRONOMICAL CLOCK.

We make only one kind of clock, which we supply with our cheap outfit. It is a well-made Clock, having dead-beat escapement, mercurial pendulum, and break-circuit attachment. In this Clock this is done by the pendulum. 9-inch full minute dial, extra second and hour dial.

Price..... \$160 00

NOTE.—Owing to the difficulty of transporting mercury, we do not furnish it with Clocks. The pendulum jar is marked up to where it has to be filled with mercury.

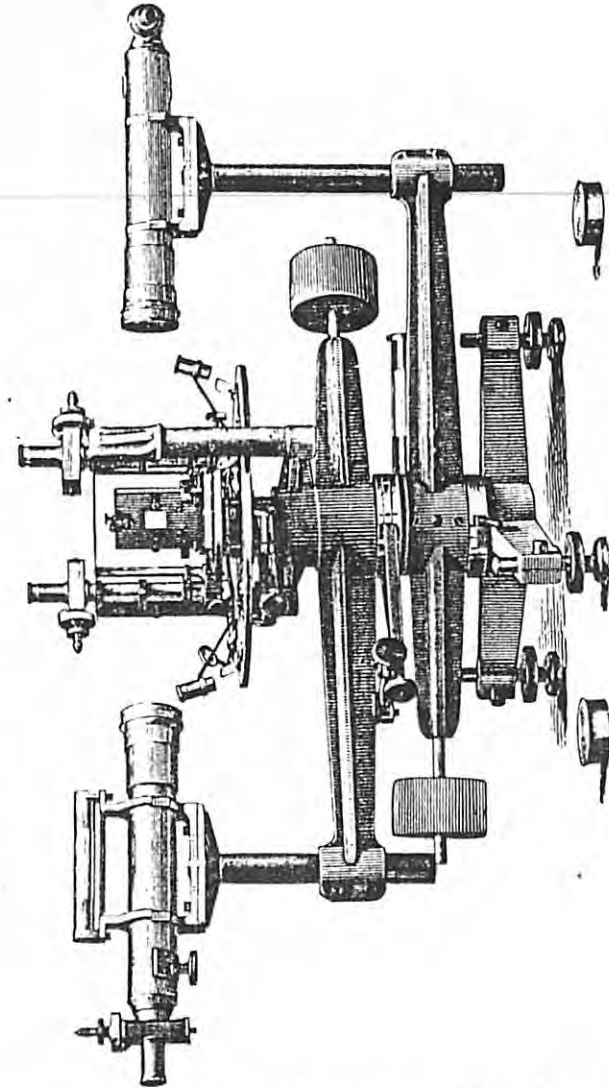

Spectrometer Designed by Prof. C. A. Young.

We have made several sizes of this instrument, with circles from 12 to 18 inches in diameter, and telescopes from 2 to $2\frac{1}{2}$ inches aperture. The circle is read by means of two micrometer-microscopes to single seconds; these microscopes are attached to the arm carrying the observing telescope. The collimating telescope turns on a separate axis, and the whole instrument can be rotated on another axis. The grating table turns on a center of its own, to which are attached two verniers reading to $\frac{1}{5}$ seconds. Both telescopes turn in adjustable Y's.

The price of these instruments varies according to size.

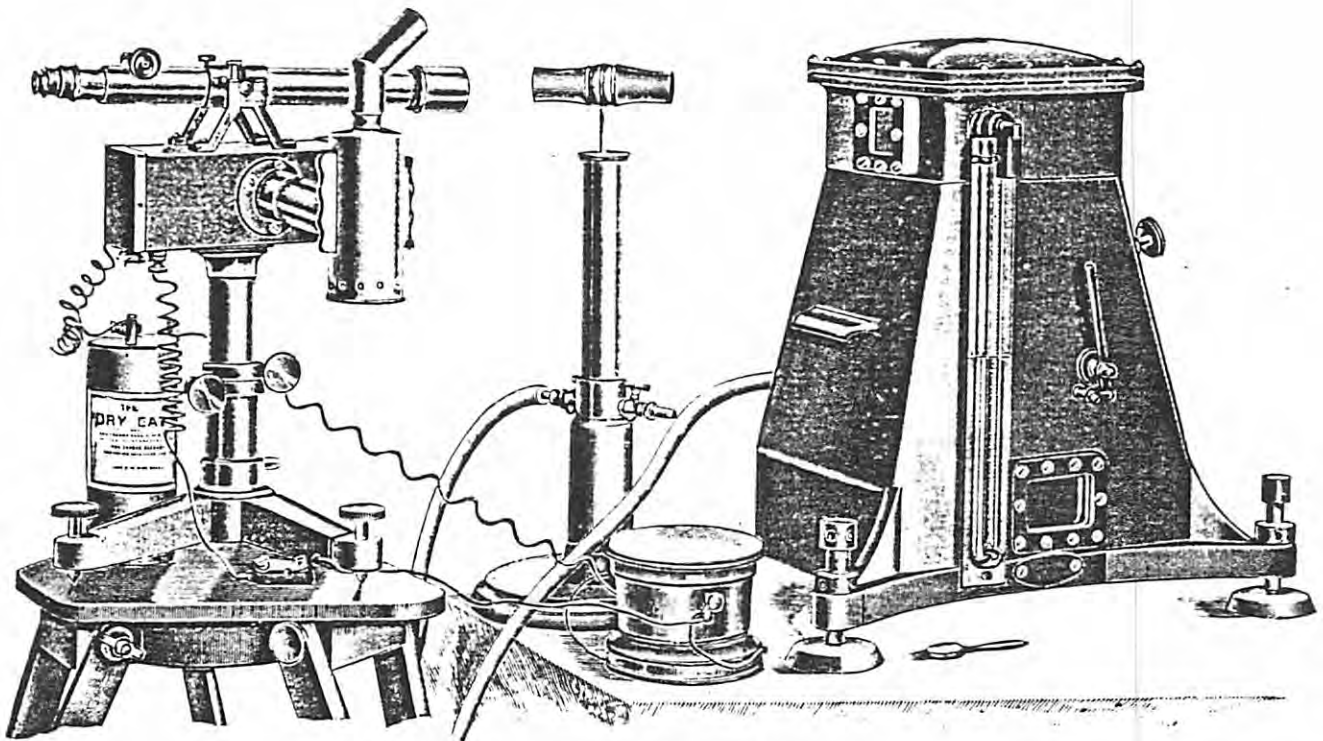

Coast Survey Pendulum Apparatus.

For description of this Apparatus, see United States Coast and Geodetic Survey Report for 1891.

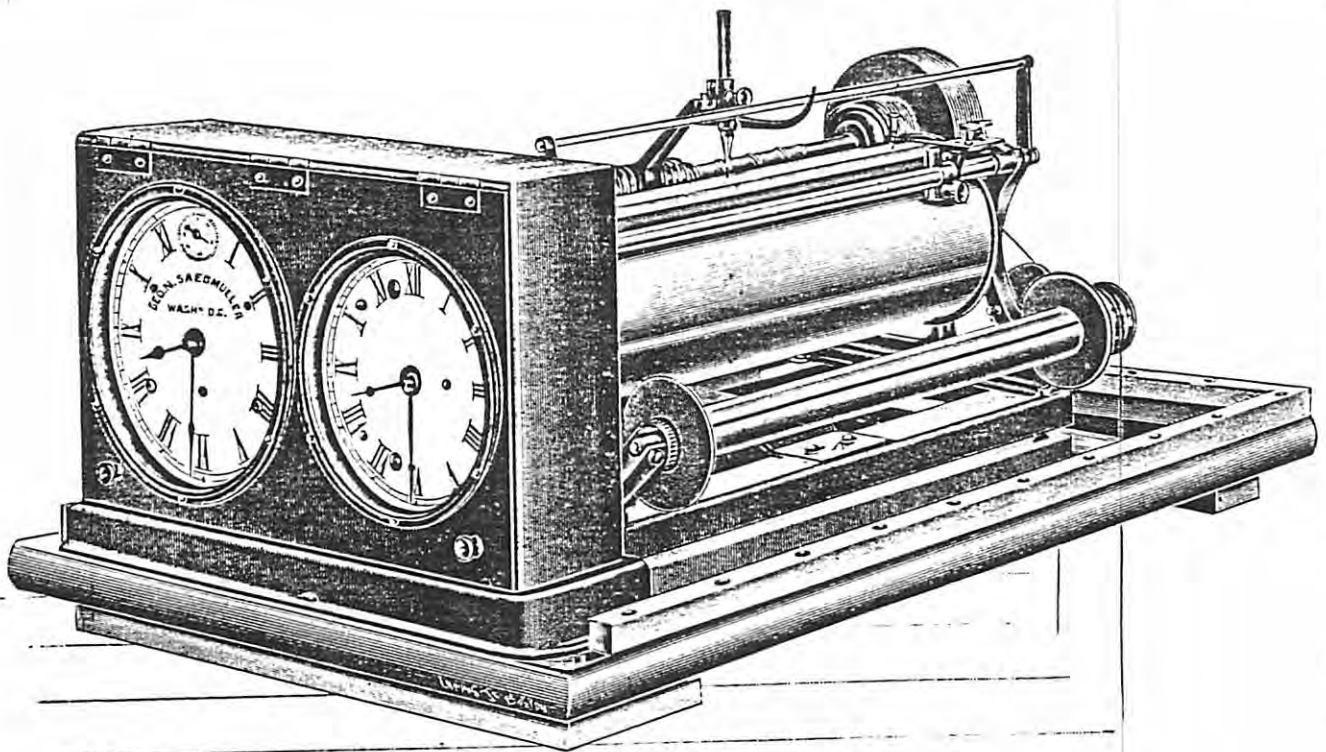

Coast Survey Tide Gauge.

Two clocks are used, one for driving, the other for keeping time, which insures excellent results.

Price..... \$350 00

EQUATORIALS.

The great interest which has been taken in late years in celestial photography and spectral analysis has of necessity brought forth great improvements in equatorial mountings.

Rigidity in the whole apparatus and the utmost regularity in the action of the driving-clock are especially necessary. By the extensive use of steel and by judicious ribbing and bracing of parts we gain lightness without sacrificing strength. This is especially desirable in the parts which move and have to be driven by the clock.

The fixed parts, such as the pier and head-stock, may be made heavy; there is no harm in any excess of weight, as it tends to increase the stability. There is, however, no use in putting more there than is necessary, and for this reason the shape of those parts should be so chosen as to give them the utmost stiffness with a given amount of material.

The best possible cross-section for a pillar is the round one, and we have adopted it for this reason, and because it requires less space than any other shape. We forego the advantage of a closet, which the square pier affords, for the sake of greater beauty and strength.

Experience has fully demonstrated the superiority of the round pillar.

The Driving-Clock is of special importance. We have calculated for different telescopes the required sizes of the clock and the number of foot-pounds they should control per hour. We arrived at these conclusions by ascertaining what weight was actually required to drive existing telescopes of different sizes.

The Regulator or Governor is the most important part of the clock. We experimented with a great many, and found the friction regulator, as suggested by Prof. Young, to be the best. This governor is so constructed that any increase in speed produces increased friction, thus retarding it again. By carefully calculating its dimensions we get it as astatic as possible, and secure a high degree of power and sensitiveness. By selecting materials with the required coefficients of friction we can make it more or less powerful. The angle which the arms make with the vertical driving-shaft must be carefully determined, and for this reason we effect the regulation for speed by moving the balls up or down in the direction of the arm.

The Electric Control is now universally applied to all telescopes of considerable size, as it corrects the small irregularities due to a varying load and keeps the driving-clock in unison with the standard clock. The simplest and most effective electric control we consider to be the one contrived by Prof. J. E. Keeler, which consists of a soft-iron sector clamped to the vertical axis of the governor, rotating in a horizontal plane. The sector passes very close to the poles of an electro-magnet, mounted on a slightly elastic standard of steel. At every second a strong current is sent through the coils of this magnet by means of a standard

clock, the circuit being closed. The driving-clock is set so as to run a little too fast, and when the governor is started the sector continually gains until it reaches the magnet of the control, when the friction produced by the attraction of the latter prevents any further acceleration. With this control no shock is communicated to the telescope. By making the magnet movable about the axis of the governor, it can at once be set to the proper position after the governor has attained its maximum speed, and then be clamped. If the governor rotates faster than once in a second, the sector can be applied to the train below the governor. Whether the polar axis will rotate with a correspondingly uniform motion depends upon the perfection of the gear-cutting in the intermediate parts of the train, and especially in the accuracy with which the worm-wheel has been spaced.

The best control is one applied to the driving-worm, as it corrects all the errors of the clock and intermediate train; it is, however, expensive, and requires a most accurately cut worm-wheel.

The Worm-wheels in our Equatorials of the larger size are spaced on our dividing engine and then cut on a specially constructed apparatus; the teeth are not only spaced accurately but are cut with the correct pitch, as the cutting tooth moves forward while cutting an amount equal to the pitch.

We employ two worm-wheels: the large one is loose on the polar axis and is driven by the worm connected with the clock. A smaller worm-wheel fits loose on the large one, to which it may be clamped from the eye end of the telescope. The declination sleeve carries the worm gearing into the smaller wheel, and this worm can also be operated from the eye end. It will thus be seen that by clamping from the eye end the clock will drive the main worm-wheel and the telescope. By turning the worm which gears in the smaller wheel from the eye end, the telescope can be moved *with* or *against* the clock without checking or retarding it, and the motion is continuous, being only limited by the clamp.

It is certainly a great convenience to be able to move the telescope from the eye end both in R. A. and Declination, but it will not do to use these motions to correct by hand for long exposure in photography, as it would cause the telescope to tremble. Hand correction is necessary, especially in large telescopes, as no electric control or the most accurate gear cutting will remove the errors caused by change of refraction and flexure. This hand correction we effect by giving the clock-worm an independent motion by means of epicycloidal gearing.

Anti-friction devices are a necessity in large telescopes, especially for the polar axis. The simplest and the most elegant is the one devised by the Repsolds, to whom nearly all improvements in equatorials are due since the immortal Fraunhofer devised the now universally adopted German plan of mounting.

Near the upper end of the polar axis, just below the worm-wheels, is a steel collar turned to such an angle that its lower surface is horizontal. Against this

collar a vertical friction roller is forced up with a pressure equal to the weight of the moving parts of the telescope, and these moving parts rest thus on the roller in unstable equilibrium. The relief of pressure is precisely proportional to the pressure on the bearings.

We have modified this arrangement by using a number of rollers which turn loose on a spindle. As the collar is part of a cone, the roller pressing on the larger part will revolve faster than the one pressing against the smaller part, and there will be a little differential movement between the rollers. By using a number of rollers—the number depending on the size of the telescope—the weight to be relieved is proportionately divided among them all, each one bearing its part. The contact between roller and collar can thus be made very small, as theoretically it should be a point. But a point will not sustain much weight, and in order to overcome the grinding friction which would result from a broad contact between a conical and a cylindrical roller we divide up the weight among the number of rollers. Each one is slightly rounded and touches the collar only in the middle.

Excepting for very large telescopes there is no use to relieve the friction of the Declination axis.

Hand-wheels, by means of which the telescope can be turned in R. A. and Decl. from the floor, are a great convenience in large instruments. We place them on the south side of the pier, where they are out of the way.

Finding Circles.—In order to see where the telescope points to when operating these hand-wheels, we have introduced, for larger instruments, finding circles with pointers, which indicate, with sufficient accuracy for finding purposes, the R. A. and Decl. to which the telescope is pointing. In order to prevent the Declination Circle from turning when moving the telescope in R. A. an epicycloidal train is introduced. By the use of a clock, driving a pointer, the instrument can at once be set in R. A. without calculating the hour angle.

To attach the finding circle to the eye end of telescopes is only feasible in large instruments. In smaller ones the gears have to be made so small that they are difficult to secure to the rods, and the back-lash in a small gear is much more than in a large one.

For most purposes it is good enough to set by large circles which are provided with bold graduations and numbers, visible from the floor.

It must be borne in mind that the simpler the construction, the less work the clock has to do.

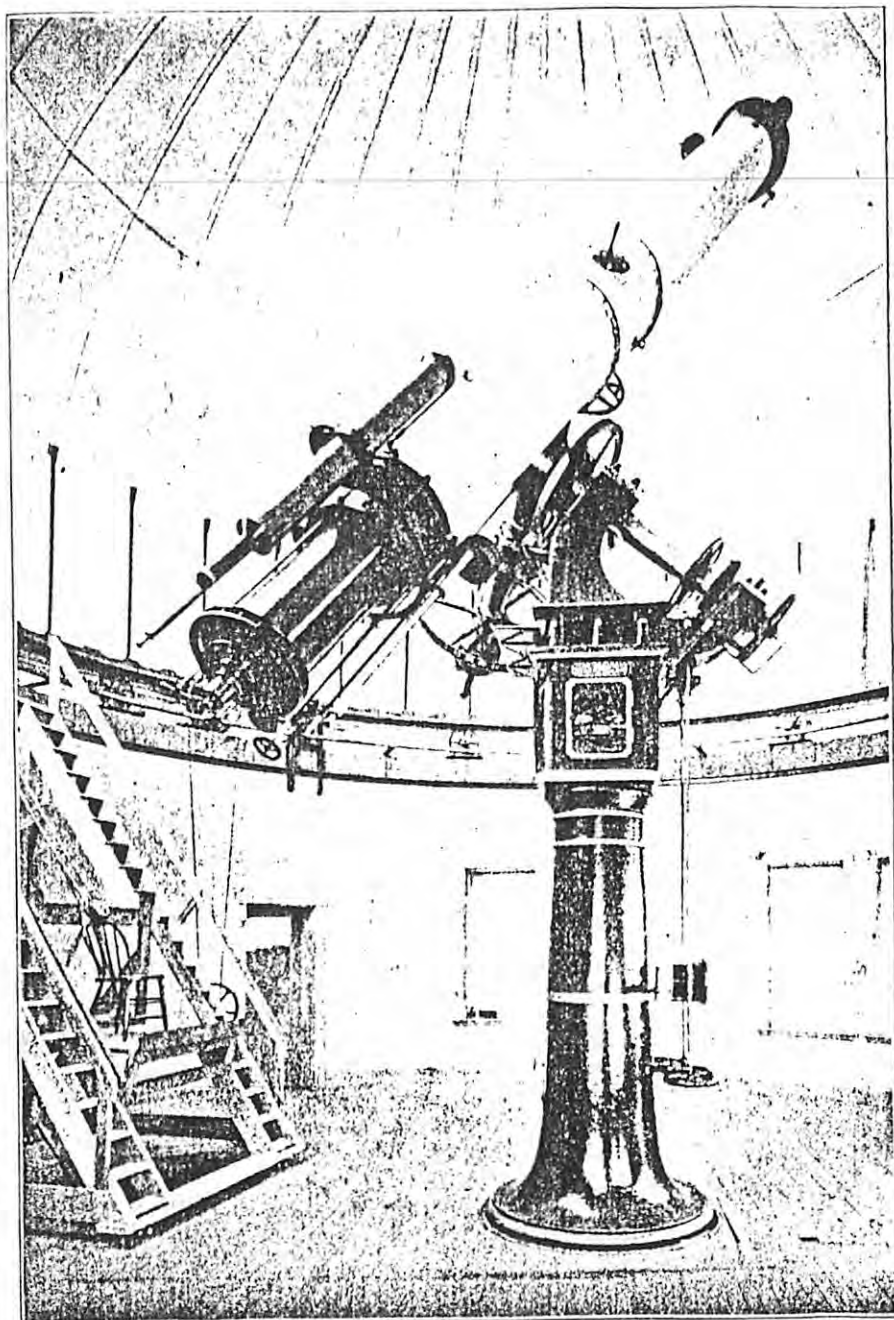

Denver Equatorial, 20 inches Aperture.
Designed and constructed by G. N. Saegmuller, Washington, D. C.

The following appeared in *Astronomy and Astro-Physics*, November, 1894:

THE 20-INCH EQUATORIAL OF THE CHAMBERLIN OBSERVATORY.*

H. A. HOWE, DIRECTOR.

The work of mounting the twenty-inch equatorial of the Chamberlin Observatory was begun in July, and the instrument is now in fair shape for use. The fact that the writer was able to get the instrument together without mistakes, and without the help of any skilled mechanics, speaks well for the care which was exercised in fitting and marking every piece in the shop. As this is the first large mounting of Mr. Saegmuller's construction which has been set up in this country, astronomers will be interested to know about its peculiarities, together with the excellencies and the faults (if any) of its construction. First, however, for the object-glass:

THE OBJECTIVE.—The discs for this were obtained of Foil and were figured by Alvan G. Clark. They are well-nigh perfect specimens of optical glass: the crown lens is free from strain, and the writer could find only three or four small ones in the flint lens. No polarization was shown by the ordinary test by reflected light, using a Nicol's prism. There is but one noteworthy bubble, which is a millimeter and a half in diameter. The color-correction is better than the writer expected with so large a glass of the usual type, and the defining power is exquisite.

GENERAL DESCRIPTION OF THE MOUNTING.—The pier on which the instrument stands is built of a tough sandstone, being faced with dimension-stone, and filled with heavy-rubble work. Its foundation is grout. The pier is 16 ft. square at the base, 12 ft. square at the top, and 25 ft. high, its base being 12 ft. below the surface. Into this pier are let three steel bolts, 9 ft. long and 3 inches in diameter. Their heads lock into horizontal foot-plates 2 ft. square, imbedded 7 ft. deep in the masonry. On top of the pier lie three similar plates, through which the bolts run, and to which they are held by very heavy nuts. On these bolts is supported the 7,000 lb. casting (not shown in cut but below the floor), which forms the lowest section of the pillar, its top being nearly flush with the floor of the dome room. The adjustment of the instrument in latitude is made by lifting the entire column by means of the adjusting nuts on the north bolt. Upon this massive tripod stands a bell-shaped casting 5 ft. in diameter at the base and about 5 ft. high, to which is fastened by bolts running through internal flanges a second casting, on which in turn stands the square clock-case. The adjustment in azimuth is beneath the floor, the bell-shaped casting being rotated by three pairs of opposing adjusting screws. The clock box can be shifted in azimuth (without adjusting screws) and is held in place by four set screws inside the pillar. The headstock is of a peculiar form, and projects far to the south of the pillar, so that the centre of gravity of everything above the clock-case is well in toward the geometrical axis of the pillar. The weight of the entire instrument is 25,000 lbs.

ANTI-FRICTION DEVICES.—The polar axis is a fine piece of Mildale steel resting in phosphor-bronze bearings. The friction at the upper bearing is relieved by a set of six hardened steel rollers, each a foot in diameter and a quarter of an inch thick, which stand vertically side by side on the same axis. This axis is supported in an anti-friction bearing composed of small hardened steel cylinders. The system of rollers is nearly under the centre of gravity of the moving portion of the instrument, and is pressed upward by a powerful bar spring inside of the headstock. Any desired tension is put upon the spring by means of a worm-gear, and the polar axis may thus be lifted entirely off its upper bearing.

* Communicated by the author.

The comparatively slight tendency of the lower end of the polar axis to rise is counteracted by a friction roller placed above it. The end thrust of this axis is small and is taken by a ball-bearing at the lower end of it.

The declination axis runs in plain bearings, but the end thrust is taken by a ball-bearing at each extremity of the axis. The ball-bearing at the small end of the axis is adjustable and firmly secured by a set-screw. A practical advantage of having plain bearings on the declination axis is that when the instrument is near the meridian, so that there is very little pressure on the ball-bearings, the friction is sufficient to keep the instrument from rotating when the micrometer is put on or taken off. Thus no manipulation of the counterpoises is necessary. The large screw on which the counterpoises for declination are strung is not a continuation of the axis, but of the sleeve.

DRIVING CLOCK.—The driving clock has a Young's double conical pendulum, the friction shoes of which are shod with vegetable fibre. The vertical spindle which carries the pendulum, carries also near its lower end a horizontal wheel, on the lower face of which are set two diametrically opposite armatures, which revolve over opposite pairs of helices, for electric control. The pendulum makes two revolutions in a sidereal second, and the helices are supposed to quicken or to retard its motion, as may be necessary. The clock train carries a chronograph which may be used either for regulating it, or for ordinary noting of time. The clock may be started, stopped, or wound from the floor, and runs so admirably that an electric control seems almost a superfluity. An electric motor for winding the clock is in contemplation. In winter heated air from a room below rises inside the pillar, and keeps the clock warm by day and by night.

MAIN CIRCLES.—Each vernier of the hour circle is read from the floor by a reading telescope near the dial box on the south face of the pillar; the smallest reading is one second, but half a second may easily be estimated. The verniers of the declination circle are read from the eye-end by two telescopes, the smallest reading being 5 seconds of arc. The divisions on both circles are exceedingly satisfactory in point of sharpness and distinctness.

SETTING CIRCLES.—The observer, when on the floor, sets the instrument to any desired right ascension and declination by turning the hand-wheels on the south side of the pillar, and reading the two dials contained in the large cylindrical box, which is above them, on a level with the eye. Each dial hand moves at double the angular speed of the corresponding axis. The declination dial is figured from 0° to 90° each way, the smallest space being 1°. The right ascension dial has five-minute spaces, and is driven by an eight-day clock. Notwithstanding the large number of gears involved in driving this mechanism, the total backlash is so small that a star of known coordinates is brought near the center of the finder at once.

It is important to have another system of setting circles visible from the eye-end when the observer is on the north side of the pillar. This system consists of a 4 ft. circle on the declination sleeve which is read by the naked eye of the observer at the eye-piece to the nearest quarter of a degree with entire ease, and a 3 ft. circle on the north side of the clock box, which is similarly read to the nearest minute of hour-angle.

ILLUMINATION.—As the entire building is lighted by an alternating current at a pressure of 50 volts, this current has been utilized for the two-candle power lamps, which illuminate the verniers of the main declination circle, the large setting circles, the micrometer, the hand lamp, etc. The main hour circle is lit up by two lamps of 16-candle power each, which are so placed that they light up the dials south of the pier as well. As the voltage of the house current is too high for the small lamps, it is run through a special converter made by Mr. E. G. Richardson, of Denver, and presented by him to the Observatory. The converter carries a switch by which the voltage of the secondary current is made to suit the small lamps, which are arranged in parallel, and are thus as easy to control as the house

lamps. The light is steady, and there are no batteries to require attention. This method of illumination is so eminently satisfactory that it is urgently recommended to all Observatories which have access to an alternating current.

The converter is inside of the pillar, about 4 feet above the floor, and is reached through a large opening on the north side of the pillar. The secondary wires run up from the converter through the clock case, thence out of a hole in the nose of the headstock, up through the polar axis (which is hollow) into the declination sleeve, emerging at the inner end of the sleeve, and being there attached to a series of concentric rings. Springs fastened to the telescope tube, and pressing against these rings, lead the current to all required points on the tube. All switches are placed just where they ought to be, and the writer expects great satisfaction from the completeness and easy manipulation of the electric lighting.

THE EYE-END.—To the end of the main sheet steel portion of the tube is attached a short cylindrical casting upon which rotates a spectroscope jacket, similar to that on the Lick telescope. In order to adapt the tube to photography, the entire eye-end has been made to slide upwards a distance of about 3 feet, being guided by four steel rods, which run in eight guiding lugs within the casting which supports the spectroscope jacket. For visual work this sliding piece is pulled out as far as possible, and for photography it is thrust clear home, so that the photographic focus lies outside of it. In either position the sliding rods are held by clamp screws. At the lower end of the sliding piece is attached by a bayonet joint the tail-piece proper, consisting of the focusing tubes. The tail-piece has lateral adjusting screws, so that the sight line may be made perpendicular to the declination axis. There is but one finder, of five inches aperture.

MICROMETER.—This attachment varies in some particulars from the ordinary American form. The verniers and the pinion for rotation in position angle are fixed, while the position circle revolves. Thus the observer can always find the pinion and the verniers, without loss of time. The circle which is 9 inches in diameter is divided to each tenth of a degree, and can be read by the verniers to hundredths if desired. Parallel to the movable micrometer wire is a system of wires, spaced at distances of 5 minutes of arc, for facilitating observations of comets or asteroids. There is but one fault to be found with the micrometer, namely, that in certain positions the ends of the box are over the verniers, making them inconvenient to read. It is only just to the maker to state that he has promised to remedy this defect, together with any others which the observer may discover, after using it awhile.

ADAPTATION TO PHOTOGRAPHY.—The crown lens of the objective is reversible, the two lenses being then separated by several inches. To accomplish this the telescope is pointed to the nadir, and the lower end of the tube is fastened to the pillar by a simple device. A reversing carriage is then run under the objective, so that the crown cell, which weighs about 150 lbs., is safely taken off, turned over and put back. When one wishes to photograph, the 5-inch finder and the entire system of handles for clamping and executing slow motions in right ascension and declination are slid up the side of the tube so as to be out of the way of the photographer though still usable. The tail-piece is then removed, and the plate-holder attached in its place by a bayonet joint. The plate-holder is movable in both right ascension and declination by five screws, the backlash being controlled by powerful springs.

For "following" there is a photographic finder, the objective of which is 5 inches in aperture, and is mounted on the outside of the main telescope, close by the 20-inch glass. The eye-end of the photographic finder is a small micrometer, which is attached to the plate-holder by a sliding mechanism, which allows the micrometer to be moved quite a distance in right ascension or declination or both, till a star suitable for "following" is found, and placed at the intersection of the spider webs. It is hoped that the displacement of the

image on the photographic plate by changes of refraction, differential flexure of the tube, etc., will be practically the same as the displacement of the star which is used for "following." If there is any twisting of the plate about the line of collimation as an axis, it may be possible to detect it by turning the position-circle of the micrometer so that one of the spider-webs shall bisect two stars at opposite sides of the field of view. No mechanism has been provided for correcting such a twist, but should the twist be discovered, it will be easy to attach the plate-holder to the rotating spectroscope jacket, the motion of which is controlled by a worm.

REMARKS.—As it is well known that Mr. Saegmuller strives to build his instruments as light as is consistent with proper strength, some astronomers have feared that a large telescope of his construction might lack rigidity. This mounting is not open to such a charge, and must be considered as reflecting great credit upon its maker.

THE OBSERVING CHAIR.—This is 13 ft. high, 6½ ft. wide, and 9 ft. deep. The platform (4 ft. by 3) slides up and down on four heavy trunk rollers, and is supported by a three-quarter inch Manila rope which takes a turn and a half around a six-inch oak drum; it is so counterbalanced as to require only the pressure of one finger to raise it. If two or three heavy persons are to be on the platform at once, an extra turn of the rope around the drum gives security against sliding downward. The chair is mounted on four of Martin's truck castors, which are equipped with anti-friction wheels, so that they rotate about their vertical spindles easily. A ring of iron concentric with the top of the wall of the room, and 3 ft. less in diameter, keeps the chair from running against the electric lights, etc., on the wall. The chair works very satisfactorily.

UNIVERSITY PARK, COLO.

UNIVERSITY PARK, COLO., March 25, 1898.

DEAR MR. SAEGMULLER:

You ask me to state how our twenty-inch Equatorial has behaved itself during the three and a half years that I have observed with it. It has been used in quite extensive series of micrometrical measures and has acquitted itself admirably. All adjustments have been made easily and accurately. The instrument has been stable, and is exceptionally convenient to handle. Your method of relieving the friction on the polar axis has proved to be eminently satisfactory. The driving clock runs with smoothness and accuracy, no matter what the external temperature may be. Very little attention is needed to keep the instrument in perfect working order. The Bruce micrometer is superior to any other which I have ever seen.

Very truly,

H. A. HOWE.

For a more detailed description of this instrument we refer to "Engineering" of May 28, 1897, the most widely known engineering paper published in England. Six pages of letter press and illustrations are devoted to the description of this instrument.

The opposite illustration appeared in the January number of "Astronomy and Astro-Physics," together with the following descriptive letter of Rev. José Algué to the Editor.

OBSERVATORY AT MANILA, PHILIPPINE ISLANDS.

Editor Astronomy and Astro-Physics:

It may be of interest to you and your readers to learn that the telescope which has been building for our Observatory at Manila has been completed, and is now on its way to the Philippine Islands. A cut is now being made of this instrument which will be forwarded to you, as I believe it will be of interest to your readers, as the latitude of our Observatory is only $14^{\circ} 22'$ north.

The objective of this telescope is by Merz of Munich, and is of the same size as the one in Strassburg and the one Schiaparelli is using at Milan, having an aperture of a little more than 18 Paris inches, being nearly 20 inches English.

The instrument is very rigidly built, although mere weight was not the object sought after.

The telescope tube weighs about one ton, and about 5,000 pounds are being moved when the instrument is turned in R. A. It can be set in Declination and R. A. from the floor by means of two hand-wheels and finding circles, the hour circle being driven by a sidereal clock in order to be able to set directly to right ascensions.

The force necessary to move the telescope by means of the hand-wheels is about 4 pounds on a radius of 7 inches. The motions are also communicated to the eye-end, and it takes only a force of about 2 ounces to clamp and move the telescope either in R. A. or Declination. The fine hour circle can be read from the floor, and the declination circle from the eye-end of the telescope. This eye-end is so arranged that the spectrograph and photographic apparatus can readily be attached; its construction is clearly shown in the cut.

The driving clock runs for over four hours with one winding, and is provided with electric control. The illumination is by means of incandescent lamps, and in addition there is a self-adjusting oil lamp.

In design, execution, and especially cost, it compares most favorably with large telescopes of recent manufacture, and it was finished in the short contract time of 10 months.

During the time it was mounted it was examined by the astronomers of the Naval Observatory, by those of Georgetown College, and the Catholic University, as well as by many scientists, all of whom expressed their admiration for the instrument.

It was designed and built, as well as the other instruments for the Manila Observatory, already mentioned in a former number of this journal, by Geo. N. Saegmuller, Washington, D. C.

I hope soon to be able to give you more news of this instrument.

JOSÉ ALGUÉ, S. J.

GEORGETOWN COLLEGE,
GEORGETOWN, D. C., Nov. 25, 1893.

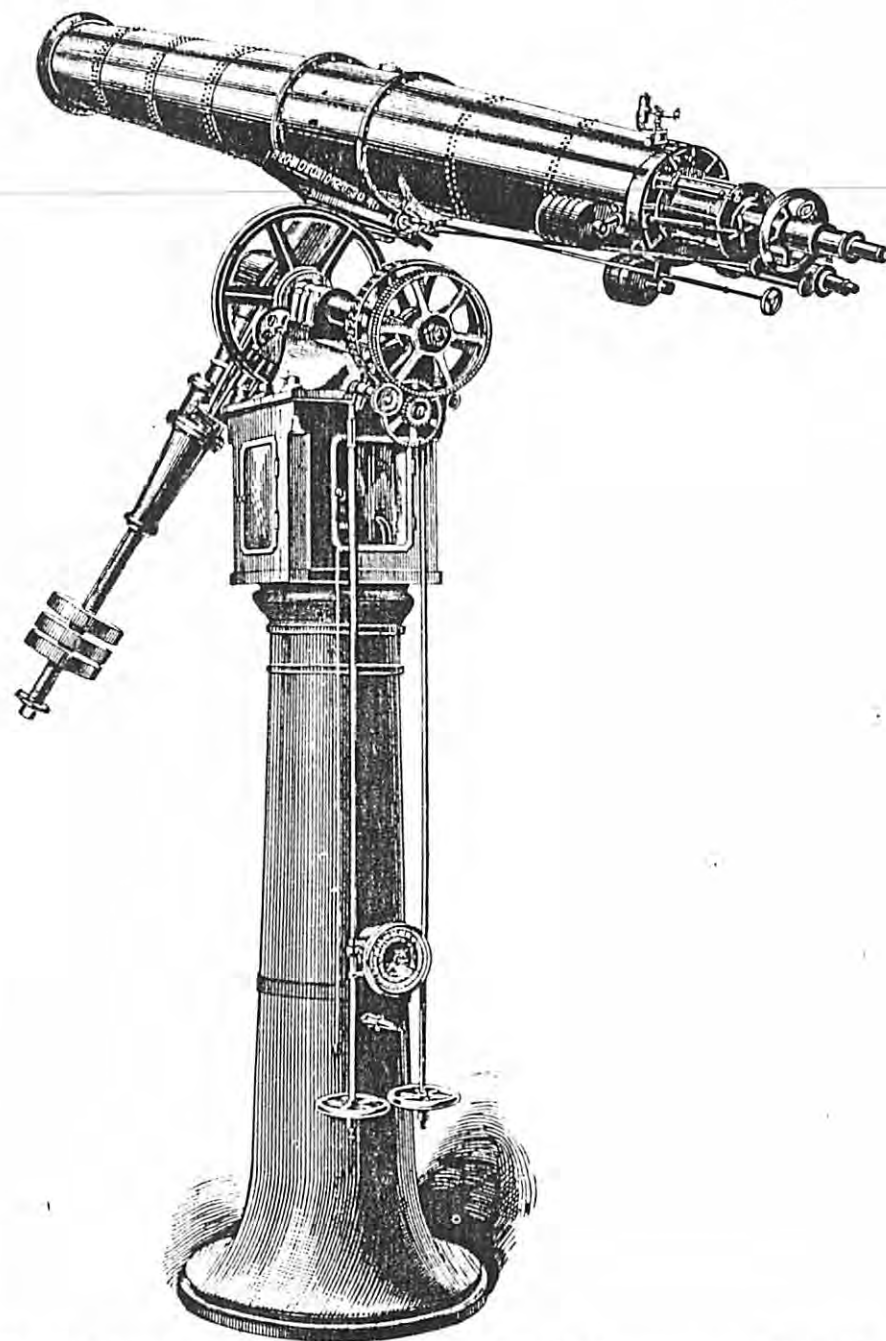

20-inch Equatorial Telescope for the Manila Observatory, Philippine Islands.

Designed and Constructed by Geo. N. Saegmuller, Washington, D. C.

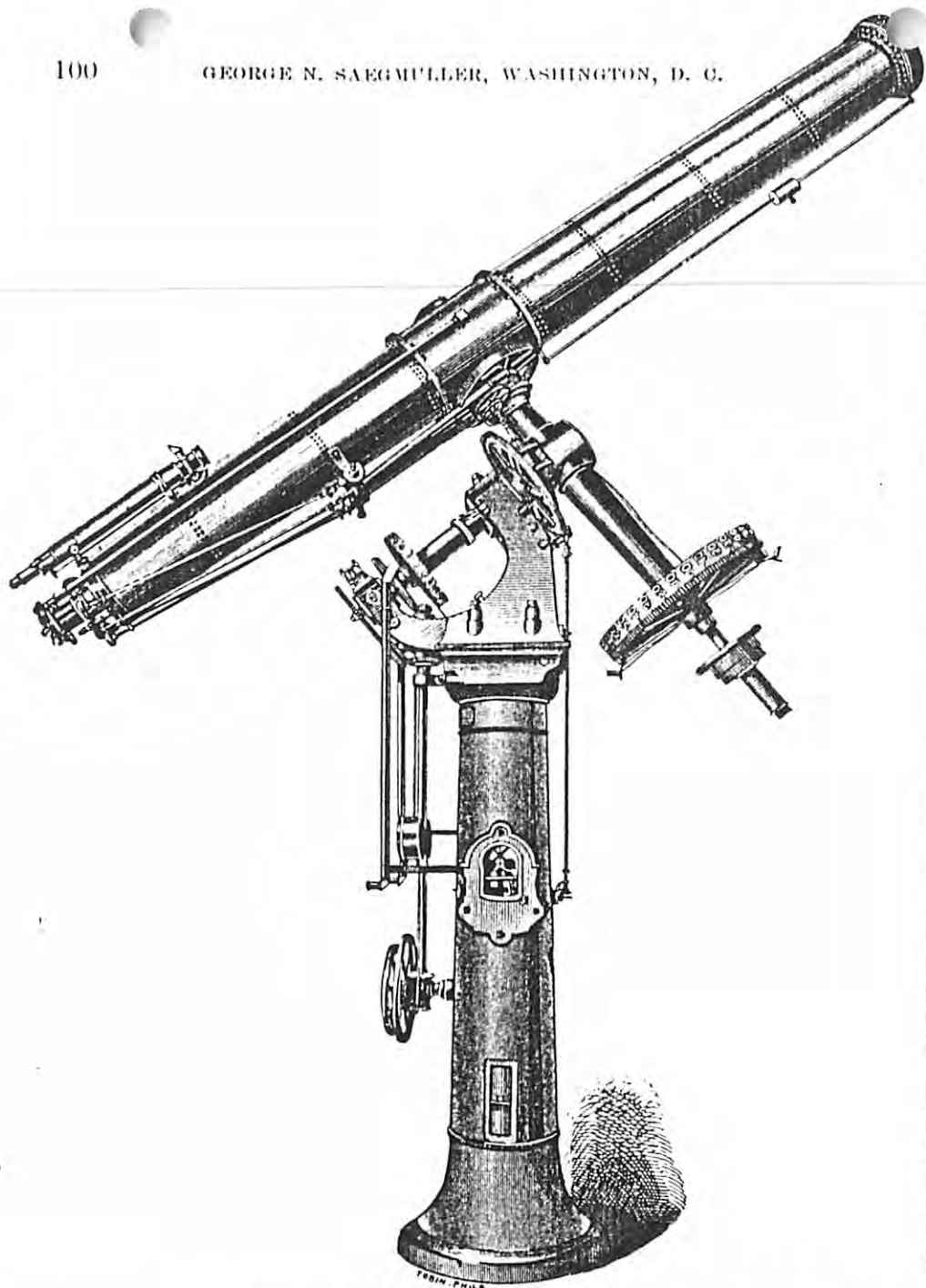

12-inch Equatorial.

As built for the New Naval Observatory, and (with slight modifications) for Georgetown College and Ladd Observatory.

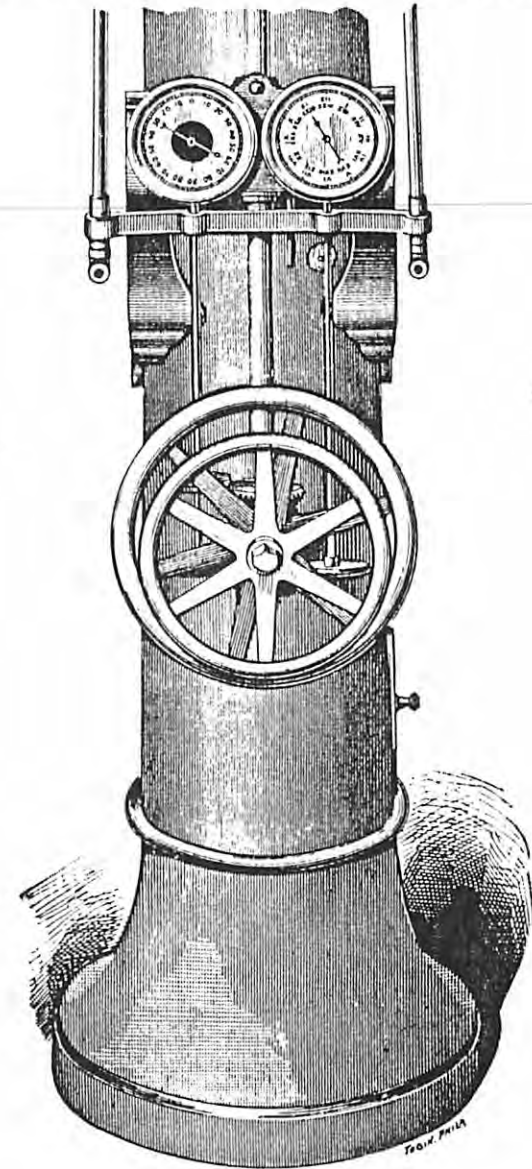

12-inch Equatorial.

Showing the Finding Circles, by means of which the telescope can be set in R. A. and Declination without looking at the fine circles on the axes. We have added these "Star Dials" on Father Hagen's telescope at the Georgetown College Observatory, and after nearly eight years' use he pronounces them the greatest improvement in Equatorial mountings which has been devised of late. Since we added them he has never used the fine circles.

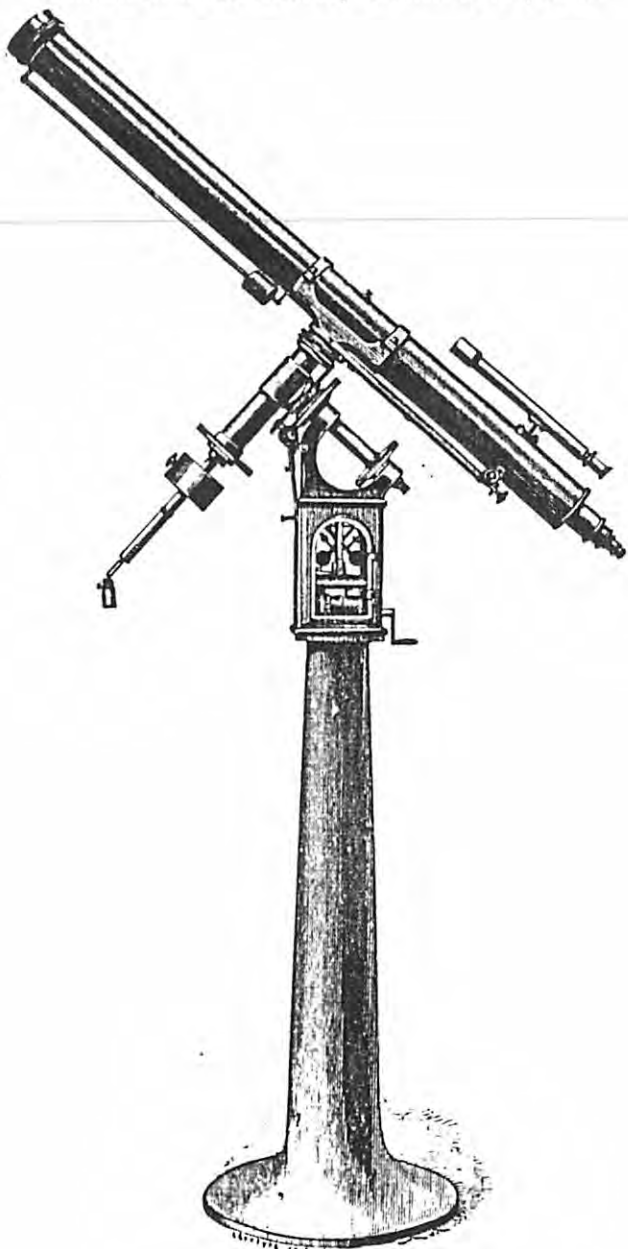

6-inch Equatorial.

With driving clock, circles, clamps and tangent motion in R. A. and Decl. led to eye end.

Price..... \$1,600 00

Prices for larger instruments furnished on application.

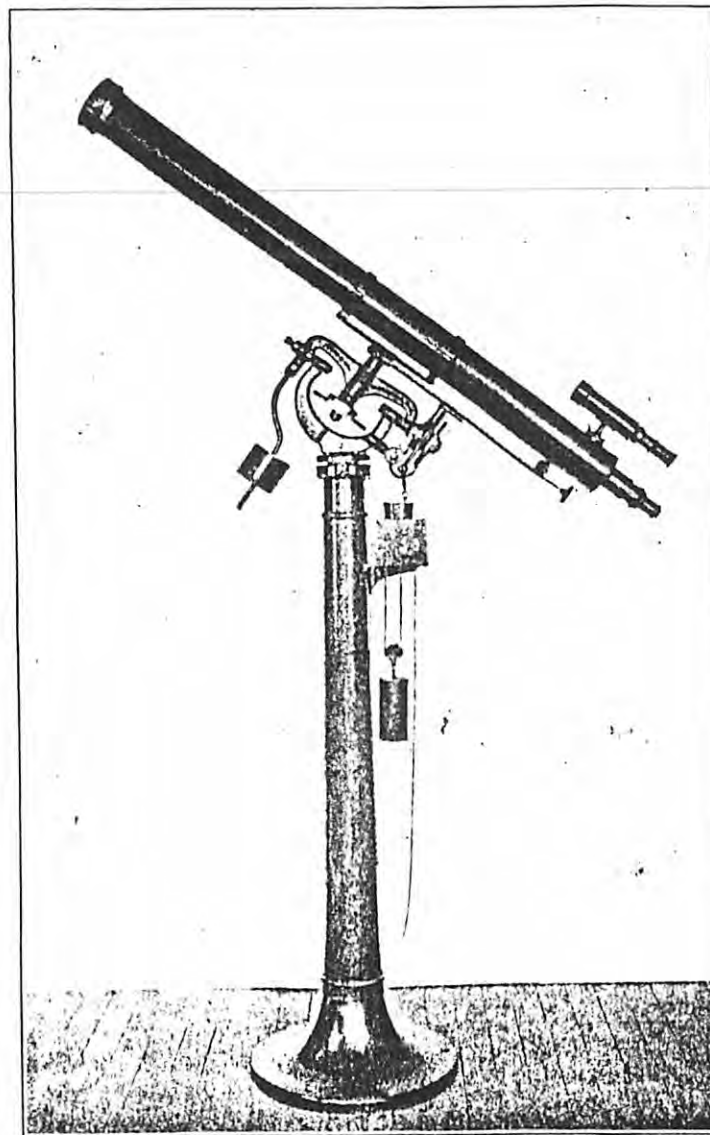

4-inch Equatorial.

Low-priced Equatorials on Iron Stand.

With circles, clamps and tangents, and clockwork.

3-inch Equatorial.....	\$465 00
4 " "	550 00
3-inch Equatorial Mounting, without telescope.....	375 00
4 " "	400 00

The same without clockwork, \$100 less.

The same without clockwork and circles, \$140 less.

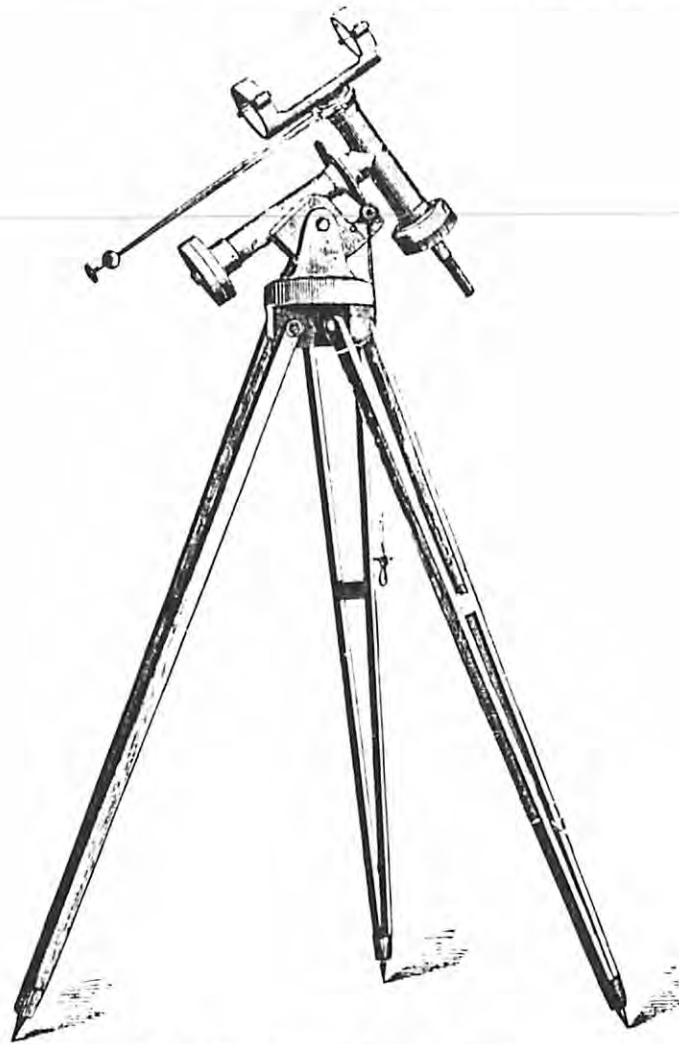

Portable Equatorial Mounting.

Above cut represents a Portable Equatorial Mounting, suitable for telescope from 3 to 5 inches aperture. As shown in the cut, it has clamp and tangent movements, silvered circles reading to single minutes and 10 seconds of time, respectively.

Portable Equatorial Mountings.

On heavy tripod stands with circles, clamps, and tangents.

For 3-inch telescope	\$80 00
" 4 " "	90 00
" 5 " "	110 00

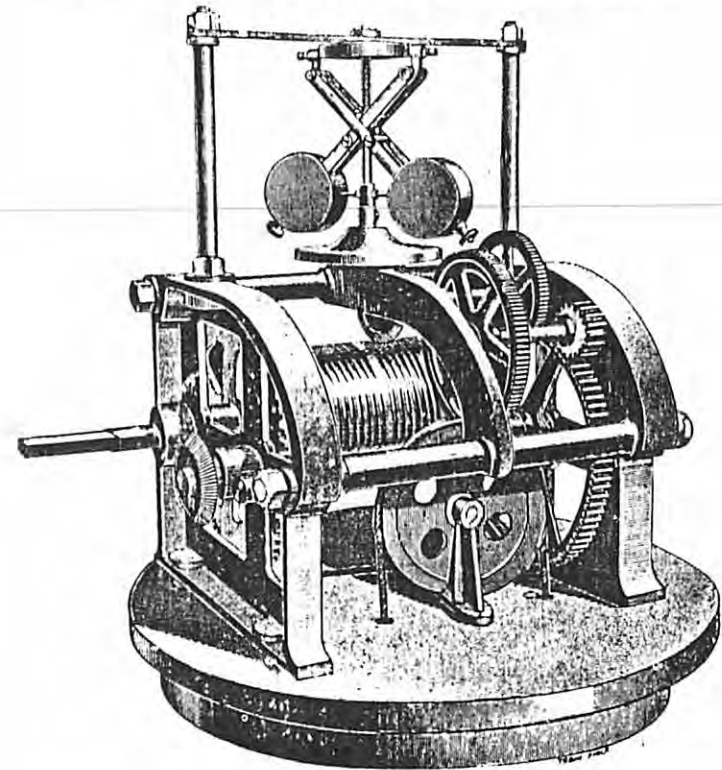

Equatorial Driving-Clock.

The above cut represents our style of driving-clock suitable for a 12-inch Equatorial. It is very compactly built, provided with maintaining power, and the weight is hung in such a manner that it descends centrally without moving in a lateral direction.

The governor is a rotating pendulum suspended in such a manner that the pendulum itself is absolutely free, while the arm on which it hangs exerts more friction as the amplitude of the pendulum increases.

With a friction coefficient of .34, this clock controls about 4,500 inch-pounds per hour.

Price-List of Astronomical Telescopes Without Stands.

The objectives of these telescopes are of the best quality and mean focal length, unless otherwise ordered. The tubes are made of brass, and the focusing is done by means of rack and pinion; to acquire a greater range an additional draw-tube is provided which is drawn in or out by hand.

Telescope of 2-inch aperture	\$60 00
" 3 " "	90 00
" 3½ " "	125 00
" 4 " "	175 00
" 4½ " "	230 00
" 5 " "	320 00
" 5½ " "	380 00
" 6 " "	500 00

MICROMETERS.

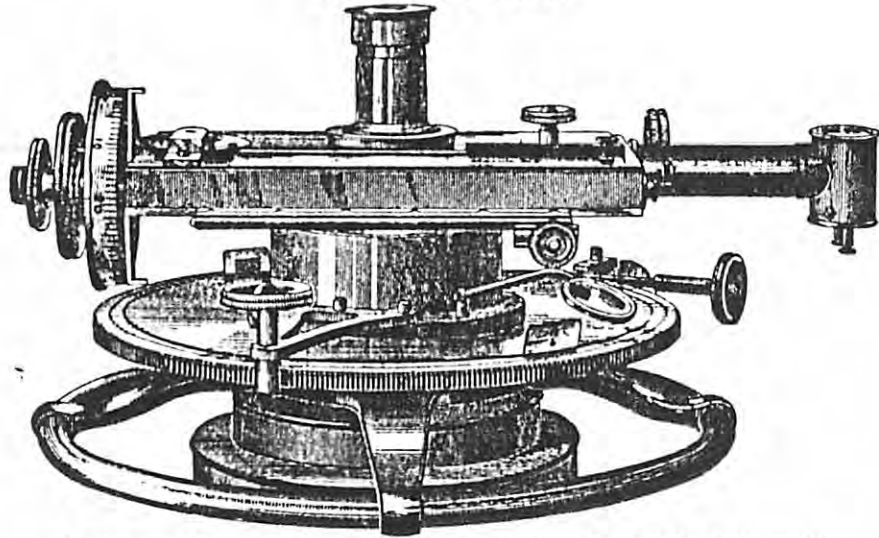

Position Micrometer, as made by us for the Lick Telescope.

Above cut represents the large Micrometer we made for the Lick telescope; it weighs about 50 pounds, and is the largest micrometer in use. We make this class of micrometers in 3 sizes.

5-inch Micrometers	\$250 00
8 " "	600 00
12 " "	900 00

The sizes refer to the diameter of the circle. The micrometers are made with the utmost exactness and with all the latest improvements. The illumination is electric and arranged for either bright or dark field.

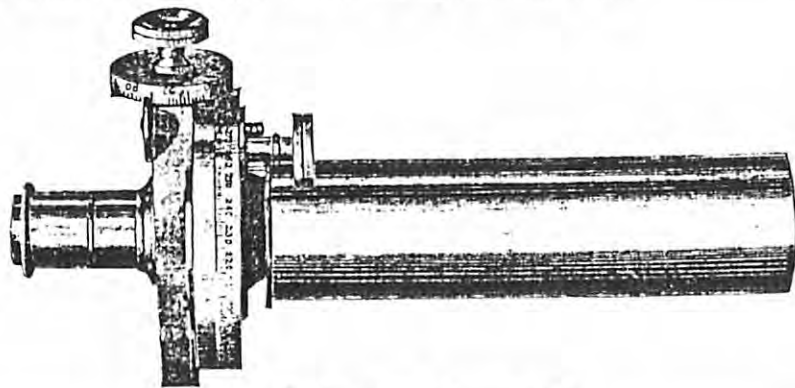

Small Position Micrometer.

Above cut represents a simple form of Position Micrometer; screw 100 to the inch; head divided into hundredths; full revolution index, 4-inch position circle.
 Price.....\$150 00

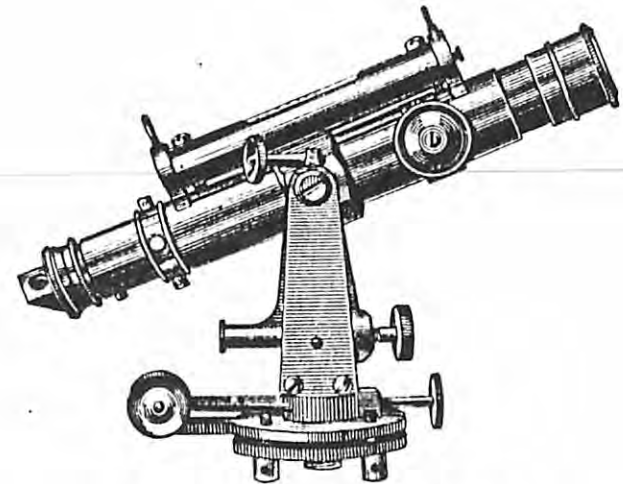

Saegmuller Solar Attachment.

Price.....\$50 00

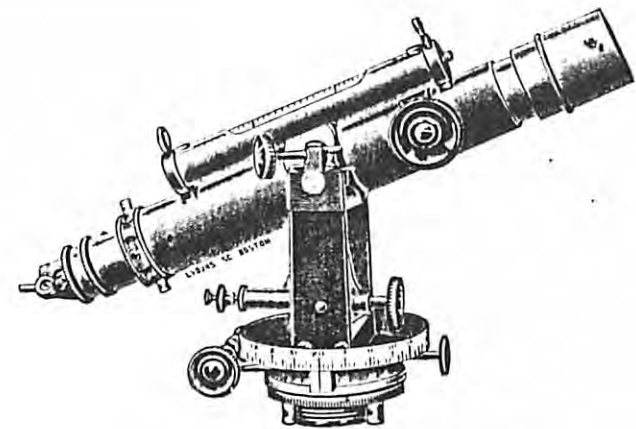

Saegmuller Solar with Hour Circle.

As the Solar is used with an instrument having a comparatively large horizontal circle, which serves the purpose of an hour-circle, as explained on page 21 (Observation for Time), it is useless to encumber it with an hour-circle. But, if desired, we provide such a circle at an additional cost of \$15.00.



Helioscopic eye-piece, Merz, according to size, from \$50 up.
 Compensation slides, of neutral tint glass, according to size, from \$5 up.
 Revolving sun-shades with 6 sun-glasses.....\$7 50

LEVEL TRIERS.

24-inch iron base with fine micrometer screw, 1 div. = 1".0.....\$25 00

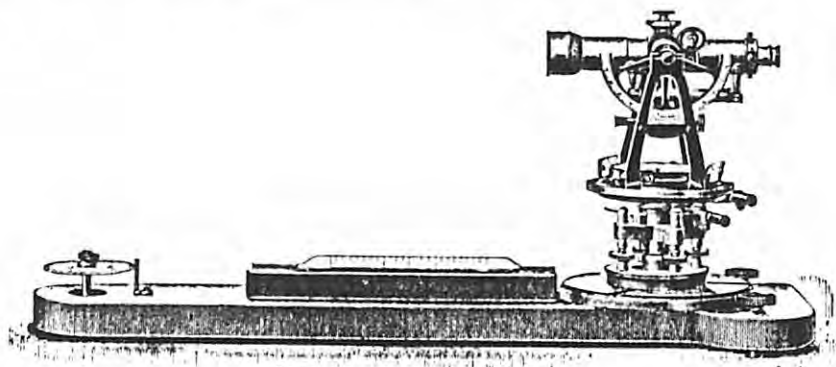

Universal Level Trier.

LEVEL VIALS.

Of all sizes and grades of sensitiveness, from \$0.75 to \$1.00 per inch. Chambered levels, reading to seconds, from \$3 to \$8 per inch.

NOTE.—Persons who do not know what patience and labor is required to produce a really good Level, having a value of one or two seconds for one millimeter space, express astonishment at the prices we ask for such a level. If we were not obliged to have these Levels for our instruments we would not make them at all; and we would rather keep a good Level vial than sell it, even at a seemingly high price.

LEVELLING RODS.

New York Rod.....	00
Philadelphia Rod.....	00
Boston Rod.....	15 00
Ranging Poles, painted red and white alternately, made of wood with steel shoes, 6 to 8 feet long.....	\$2 50 to 3 00

HAND LEVELS.

Locke's Hand-Level, nickel-plated.....	\$11 00
Abney Level and Clinometer.....	15 00

STEEL TAPES.

Excelsior Steel Tapes in leather case:	
100 feet long, divided in tenths.....	\$12 00
66 " " ".....	8 50
50 " " ".....	6 75
Chesterman's Steel Tapes in leather case:	
100 feet long, divided in tenths.....	12 00
66 " " ".....	9 00
50 " " ".....	6 50

LIGHT, NARROW STEEL TAPES.

Fine Steel Tape, 50 feet long, $\frac{1}{8}$ inch wide, with spring balance, spirit level, thermometer, and brass handles, on reel, for very accurate measurement, each.....	\$20 00
Narrow Steel Tape, $\frac{1}{2}$ or $\frac{1}{4}$ inch wide, 100 feet long, with two brass handles, graduated at every 50 feet, on reel.....	6 50
Each additional 100 feet, graduated the same.....	5 00

SURVEYORS' CHAINS.

Made of No. 12 steel, brazed links and rings:	
Land Chain, 50 feet long.....	\$6 00
" " 100 ".....	11 00
" " 33 ".....	5 50
" " 66 ".....	10 00
Meter chains, 10 meters long.....	5 50
" " 15 ".....	7 50
" " 20 ".....	10 00

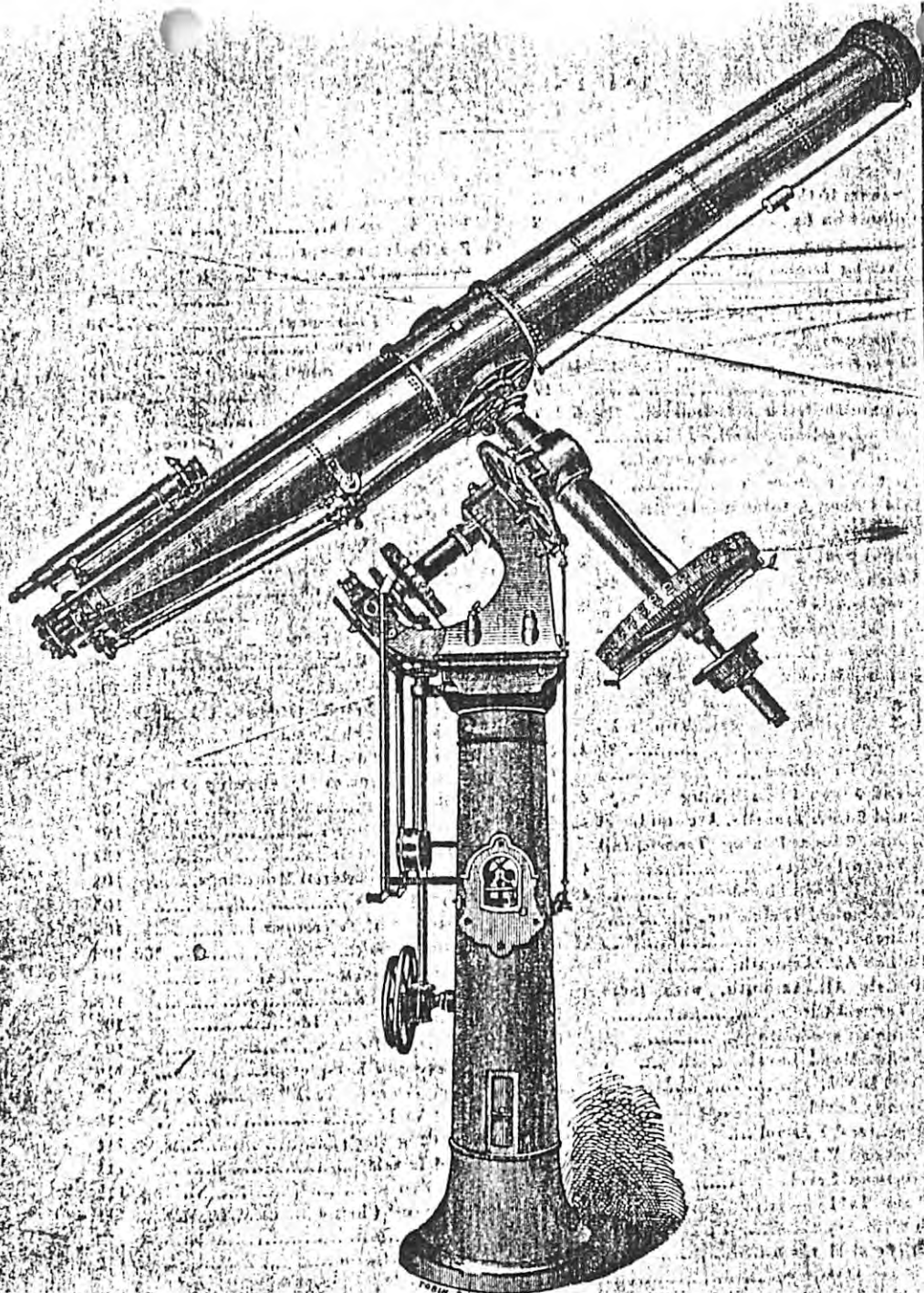

12-inch Equatorial.