

YOUNG & SONS' LINE OF CIRCULAR GRADUATING ENGINES.

MANUAL  
AND  
PRICE LIST  
OF  
ENGINEERING AND MATHEMATICAL  
INSTRUMENTS,

MANUFACTURED BY  
YOUNG & SONS,  
INVENTORS AND INTRODUCERS OF  
ENGINEERS' TRANSIT,  
No. 43 NORTH SEVENTH STREET,  
PHILADELPHIA.

INCLUDING  
Instructions in Adjustment and care of Engineering Instruments,  
ALSO,  
ACCOUNT OF INVENTION AND INTRODUCTION OF ENGI-  
NEERS' TRANSIT.

The experience of past few years has compelled us to resort to a more general use of C. O. D. method of collection than heretofore,—a matter of regret to us,—but our friends, on considering the remote and widely distant points to which our instruments are sent, and the impossibility of determining on the character of the party ordering, will recognize the necessity for this change.

Parties with whom we have no open account, corporations other than those of confirmed standing with established days of payment by monthly vouchers, will oblige by remitting with the smaller orders sufficient to cover cost of expressage and return.

The prices quoted are those at our establishment. When boxing is needed the actual cost of boxes is charged. When boxed by us we guarantee the safe arrival in good condition of the instruments to any part of the country, except under extra hazardous circumstances.

All express charges and charges for collection are to be paid by the purchaser.

On orders for *Engineering* instruments, accompanied by draft to amount of catalogue price, no charge is made for boxing, purchaser saving the cost of boxing and collection.

All instruments made by us are guaranteed to be of most skillful workmanship, most accurate construction, and of very best materials. The guarantee is not limited to any time.

FOR MORE THAN FIFTY YEARS has our establishment been engaged in the manufacture of Mathematical, Engineering and Astronomical Instruments, during which time it has always been under control of Wm. J. Young, or his Son.

For the character of our work we make but one reference—the number of our instruments throughout the country, the number of years they have been in use, and the reputation they have maintained during that time. Some of these instruments, made over forty years since, are yet in active service, doing accurate work, while cheaper instruments are being discarded after from three to four years' work.

We refer, with pride, to the introduction, by us, of the Engineer's Transit, both in its original form, and in the subsequent styles as made by us. In the earlier days of railroad construction, when transportation was slow and difficult, requiring months for an instrument to reach its destination or to be received back from instrument maker in case of repairs, our Transit was strong, simple, substantial, almost impossible to be placed out of repair. Our later instruments are replete with every modern improvement, capable of the most delicate and accurate work. From the earliest to the present time, the superiority of these instruments has been unquestioned.

Our experience has led us to produce several improvements, amongst others Gradienter, the Slide Protector, Eye Piece, Tangent, Fastening of Level Telescope, Improvement for Obviating Error of Parallax, as well as improvements on various minor points. Our self-reading Level Rod, introduced by us twenty-two years ago, is fast superseding all other styles, and the use of other rods, except on special cases, is abandoned by those who have once tried this form.



The materials in our instruments, our style and modes of manufacture, have been adopted after trial and test, during past fifty years, of all others, and our patrons may confidently rely that the various new materials and new constructions, blazoned forth periodically, have been tried, tested and discarded by us.

The graduations, the main point of all angular instruments, are, in our instruments, performed under our personal inspection, upon a line of graduating engines, superior to all others in the country. So acknowledged is this superiority, that no establishment but ourselves has attempted the manufacture of finer astronomical instruments calling for graduations of larger circles.

Making no pretensions for sale of low priced instruments, we require only such prices as will enable us to produce good instruments, and these prices will be found, for similar instruments, not exceeding those received twenty years ago.

Having endeavored, by more perfect system and increased facilities, to counteract the increased (in some cases almost doubled) cost of skilled labor, a fair comparison, including many minor points of improvements, not so evident but of cost in construction, will show prices of present less than those of past; and as it is upon the standing and character alone of the manufacturer that the purchaser must rely, we feel confident our friends have no just cause of complaint.

The establishment, at present, is under the management of Alfred C. Young, who has selected Mr. T. N. Watson, the senior of the late Wm. J. Young's partners, in the firm of Wm. J. Young & Co., to assist in oversight of the business. Mr. Watson has been engaged in various capacities in the business for over 45 years.

Combining, as we have endeavored to do, a theoretical and scientific technical education, with experience in construction in the workshop, and experience in practice in the field, we believe we have retained every possible excellence which has heretofore distinguished this establishment.

YOUNG & SONS.

## CARE OF INSTRUMENTS.

It is highly important the Engineer should understand those points in the care of an instrument, by which he can preserve its usefulness, or temporarily supply any small deficiency.

In the ordinary Compass the main point is to avoid dulling the centre pin. If point is soft, this dulling will occur from natural weight of needle. If the point is hardened carefully it will last, as far as effects of wear are concerned, many years. To preserve the point avoid all sudden jarring and jolting when needle is down, as the harder and more perfect the point the more subject to breakage from this cause. Never lift the instrument without being sure the needle is screwed up. Should the point become dull, use a small oil stone, holding it against the point, and sharpen, if possible, by revolving instrument on its centre while stone is moved slightly along. If instrument cannot be revolved so as to make centre pin revolve, sharpen by pressing stone against point and moving it in a circular direction. Do not use stone in a straight line, as then, in place of a round point, there will be one with many sides, as it were, and it will be impossible for needle to play freely.

This method will not produce a perfectly shaped point, and will only answer as a temporary relief.

The shape of centre pin should be so as to form an angle of say 15 to 20 degrees at point, keeping the upper part straight, not curved, so that on a little wear the thickness of point, if we may so speak, will not be so much greater. A dulling of point from wearing or breakage causes friction by its edges bearing against side of cap, and is the principal and almost universal cause of failure of needle to play freely. A perfect point is of greatest importance, and can only be relied upon at the instrument makers.

The height of centre pin is of consequence as affecting the ends of needle. When the centre pin, which is the same as bottom of cap centre, and the ends of needle, are of same height, the "trembling" of the needle produces no motion on its ends, and if these are on a level with top of ring parallax in reading of needle is avoided. It is preferable to have the ends of needle a trifle above the ring: breakage of point or constant sharpening of pin brings point much too low, when the only remedy is a new centre pin.

Should the North end of needle become lower than South end, the balance should be restored by sliding the brass wire on South end.

With the cap to needle the Engineer can do but little. Its shape is such that it forms a centre and nothing more, so that point rests nearly on a plane. Any attempt to smooth the cap is likely to result in destroying this form, either producing a plane surface, where the needle finds no centre and will rest on no particular point, or producing an angle, the sides of which will bind on sides of point of centre pin.

A good needle, of proper materials, and properly charged in first place, does not often lose its magnetism. It may be, when power has gone, assisted by

magnetising with a good horse-shoe magnet; but it is best not to use the magnet unless its comparative power is greater than the needle. It is an accepted theory that the needle will retain its magnetism more perfectly when allowed to lie in meridian, and for this reason it is advisable, when placed away for a long time, to allow needle to rest upon centre pin and take its natural bearing.

Object and eye glasses of telescope should be kept clean of dust, and especially grease, or anything that will form a film over glass. Small particles of dirt upon object glass are not so bad as a thin imperceptible spot of grease, &c. Wipe with a soft, well used rag,—not with silk or piece of new muslin. It is very seldom necessary to wipe the inside of glasses that are protected.

The glass next to the eye, especially in high powers, frequently becomes dimmed from moisture of eye lash. This should especially be regarded.

The object glass should not be unnecessarily unscrewed. It destroys adjustment of collimation.

The CROSS HAIR SCREWS should be used carefully, the great tendency being to overstrain them. In adjustment, be sure they come to a fair bearing with each screw; nothing more than this is necessary. Unloosen the screw on one side before tightening the other, and in erect eye pieces remember the real motion is opposite the apparent. Forgetfulness on this point is frequent source of trouble. Straining these screws is more apt to cause instrument to lose than retain adjustment.

Should any little dust alight upon cross web, it may frequently be removed by taking out eye piece or object glass and blowing gently through tube; but unless on such part of web as to interfere with use it is preferable to allow it to remain.

The TELESCOPE BEARING should be so firm as not to allow shake, but nothing more,—the friction of this will keep telescope in position. The screws which confine these bearings should often be looked to.

The telescope slide should be watched that it has no shake. If not protected by our dust protector, the slide should often be wiped. Should the slide commence to fret and grind, take it out at once, and first scrape, then burnish down the place where it has fretted. The blade of a penknife forms a very good instrument for this purpose, scraping off with edge slightly inclined, and burnishing with back of knife. Wipe out inside of tube, and if possible burnish and scrape that smooth. Grease the slide slightly, and wipe off grease before restoring it to its place. Too much grease causes dust to adhere. Do not use any *emery* or emery paper to repair slide,—it will be a continual source of trouble afterwards. A slight grinding with pumice stone dust, fine and without grit, and a little oil, may be of service, but should be carefully done, or is best left to instrument maker.

*Fretting* of centres should be treated the same way as of the slide to telescope. It is advisable, if instrument shows any sign of working hard, to take out centres, wipe them, and replace with fresh grease; but so long as centres work free, it is best not to disturb them.

It is not to be expected the Engineer will be able to repair this injury; but where fretting once commences the tendency is to become worse very rapidly, and a few moments use may destroy the slides or centres so they cannot be repaired, and unless necessity compels its continued use it is best to stop at once.

Should the fretting be in the centres and the above means not remove it

entirely, a temporary relief may be found on placing between the shoulders of the centres a washer of paper or thin card. There will then be a shake in the centre, which, however, will be a lesser evil than entire loss of use of instrument.

The best grease is good marrow, rendered. Most oils, notwithstanding their claimed qualities, gum, and become an injury to the instrument, causing it to work hard, sometimes so hard as to render instrument useless.

Fretting of parallel plate or levelling screws, can best be avoided by taking out screws, washing them with soap and water by a brush, screwing a piece of soft wood, with two sides thinned down, through the nut to clean it, and replacing screw, greasing slightly.

Tangent and clamp screw fastenings should especially be examined from time to time, that they do not become loose, allowing play in reversing instrument.

The tripod legs should have no looseness in fastening of shoes, or where the legs fit in tripod. The small screws which hold the cheeks of tripod head to the plate should be examined to see if tight. No instrument will be firm if any shake exists in fitting of legs or in shoes. It is important that the points of tripod shoes should be somewhat sharp, sufficiently so to take hold on any surface when set up. The greater the hold of shoes in ground, the steadier the instrument. Without this hold there is only the weight of instrument to resist any force, either direct or resultant, in upward direction.

In the use of all screws, bring them to a firm bearing, but do not overstrain them. Either the thread stretches and wears rapidly, or some part of instrument gives way, and eventually becomes loose by overstraining.

Moisture on glasses, either telescope, compass or vernier, can best be removed by placing instrument in a dry, moderately warm room. If time cannot be spared for this, wipe off dry, but while doing so, and in replacing them, be careful no dust or dirt gets in the instrument. In cleaning object glass, dirt is apt to fall into tube, and afterwards fall upon cross web. In cleaning vernier, dirt is apt to get between vernier and plate, bruising graduations; and in cleaning of compass ring, a small raveling of thread or lint, invisible to the naked eye, will sometimes adhere to side of ring, and prevent needle from playing. This last is frequently the cause of serious errors.

It is not advisable to take instruments apart unnecessarily. Very slight disturbances are often productive of great injury. Even where fittings are perfect it requires care and experience to place them properly together. A screw left loose, or one tightened too hard, may interfere with correct working of instrument.



## REPAIRS TO INSTRUMENTS.

Repairs to instruments injured by accident, are generally more serious than the Engineer supposes, and usually the cost of these repairs exceeds the anticipated amount. There are several reasons for this. Breakage of parts is evident to the Engineer, and he generally attributes the whole cost of repairs to this alone, whereas these evident breaks form the lesser portion of cost, the greater cost being in points only developed by more critical examination, and of which he has no idea. None but those familiar with repairing can realize the time consumed in removing what appears a trivial fault, but which the correct working of instrument requires to be thoroughly eradicated. When we consider the severe tests to which the various fittings of the instrument are subjected, by means of the graduations, of the level, and of the telescope, the necessity for repair, as near perfection as possible, regardless of time consumed, becomes evident, and the cost of these repairs explained. What may be termed, in contradistinction to the Engineer's adjustment, the Instrument Maker's adjustment, which consists in placing all parts of the instrument correctly together, so as to work smoothly, detecting any points which may be wrong, seeing that no part is strained, that the needle, verniers and plates are properly centered, &c., cannot be conscientiously and well performed in the Transit under a cost of \$10.00; in a Level under \$5.00; and Compass under \$3.00. These are independent of cost of repairs, which are charged according to time consumed.

In course of repairs, points of injury not apparent to the Engineer develop themselves, and those which appeared trifling, because of their minor importance, become serious when the more prominent are corrected; so that it happens that instruments are frequently sent to be repaired at certain points, and yet when these points are repaired, the instrument is almost, if not quite, as useless as before. We have adopted, as our rule, to thoroughly examine and repair every instrument sent, believing it most satisfactory and economical to the Engineer, and feeling assured the result is in all cases beneficial and in end satisfactory.

**TRANSIT.**—This instrument, from its being the most complicated, is the most costly to repair, nearly every part being liable to injury from a fall. Injuries to standards can generally be repaired, though where great it is generally best to replace with new, as much time may be wasted ineffectually in endeavoring to bring bearings correct.

Bending of plates from a fall, if the metal is rolled brass, can be remedied, unless the bend is "short," and severe. Where metal is cast brass a complete turning and re-graduation is generally found necessary.

Where slides of telescope are much injured by fretting, or by a fall, or by wear, a new slide is advisable as the only efficient remedy. A speedy method of closing tubes gives appearance of repairs, and though difference is not evident to Engineer, the telescope soon becomes as bad as before, and the slide will not project on true line of collimation.

Where centres or plates are injured, the cost of repairing this part, if a flat centered instrument, is about \$5.00; if a long centered instrument, ranges from \$10.00 to \$40.00. Injury to telescope is serious, from difficulty of causing them to work on line of collimation.

As a general rule, the cost to repairs to transit, even if injury is slight, will vary from \$7.00 to \$12.00; and if serious, such as from a fall, will vary, if a flat centre instrument, \$15.00 to \$30.00, and a long centre, \$15.00 to \$60.00.

Re-graduations of our graduating engine costs \$15.00.

LEVEL repairs vary from \$6.00 to \$12.00, unless new centres should be required, or heavy repairs to telescope, when the cost may extend to \$25.00 or \$30.00.

New Level tube ground uniformly the whole extent of circumference, to give uniform motion, is \$5.00.

COMPASSES are principally injured by dulling of centre pin, bending of plates and sights.

Cost of re-adjustment of needle, and re-magnetizing same, is \$3.00. New centre pin, \$1.00; cap and needle, new needle seldom wanted, \$4.50; new cap to needle, \$2.25; new glass, best French plate, \$1.00.

Repairs to Solar Compasses are especially expensive. The extreme accuracy necessary in principal parts of this instrument to a correct working, and the time consumed in instrument maker's adjustment and examination, bring the repairs to this instrument from \$20.00 to \$60.00.

We have intended these remarks to furnish a general idea to those of our friends who are inquiring of us the cost of repairs; but we would impress upon them what they expect their instrument to be and to do after repairs, and recall what we have said in reference to "instrument maker's adjustment." It is not unfrequent that when we suppose the repairs and adjustment almost finished we discover some point needing attention, which, though the consequences may be trivial, needs attention, and may possibly require as much time as the greater repairs.

Instruments sent for repairs should be carefully packed. They are at times much injured in coming to us for want of this care.

Place in box address of party sending, and memoranda of points which Engineer considers require attention, though not necessary, may be of advantage. It is advisable to place our name in full; but "Young, Instrument Maker, Philadelphia," will secure safe arrival.

## ENGINEERING INSTRUMENTS.

---

The various improvements we have added to our Instruments during past few years, have, in instances, so changed their characteristics, that our older friends and correspondents may not be familiar with them. To those desiring any particular instrument, we will mail photographs, an examination of which will afford correct idea of the improvements and details.

These improvements have for their purpose increased accuracy, and we believe have in all cases added to efficiency of instrument; but there may be circumstances, such as railway work in rough country, and in places distant from repairing facilities, where one great characteristic of our older instruments, viz., their great endurance of rough usage, may counterbalance the benefits of the additions. For this reason we still continue to manufacture our older styles as heretofore.

The telescopes, as placed upon our instruments of four or five years past, have a much higher power than heretofore, and while this high power is extremely desirable in many respects, it is necessarily accompanied in all cases by loss of light, a smaller field, more wear upon slides of telescope, a greater difficulty in focusing an object, requiring more time to work, and a greater liability to error if not properly focussed.

We advise our friends of those differences, that they act understandingly in their choice of instruments, and select those most suited to their purposes.

Graduations being the really important part of an angular instrument, such as Transit, we have devoted especial attention, to enable us to stand pre-eminent in this one point. We believe our expenditures in this line have nearly equalled the combined expenditures of all the other instrument makers, while our line of engines has enabled us to complete work not attempted in any other establishment. Our friends may rely upon the work being done under our personal supervision, the facilities in our **AUTOMATON ENGINES** enabling us to allow sufficient time in process of graduation to ensure best results; while, to avoid the unsatisfactory work arising from too common error of speedy graduation, we occupy from two to four times as long in the process as is generally occupied by others.

Experience has shown us the materials upon which graduations of our ordinary Transits are made, being brass **ROLLED** especially for us, and condensed under our trip hammer, especially adapted for the purpose, obtains a uniform density rivalling that of silver, and a hardness much to be desired. The porous nature of all castings, excepting, perhaps, yellow brass, which can be hammered and condensed, has compelled the adoption, in larger instruments, of silver or other homogeneous metals. The small air holes, and deficiencies of castings, causing the point of cutter to deviate from proper place, producing unequal spaces and unequal thickness to lines. This is one reason we avoid castings for our graduated



*plates of best instruments. The silver has very serious objection, that though alloyed, it is so soft that the least particle of dust or dirt between verniers and plates turns up edges of graduations, destroying their accuracy, in many cases obliterating graduations at the edge.*

*We consider that, for fine graduations, such as under twenty seconds, silver is best material, principally on account of surface requiring no working after graduations, to endanger obliteration of fine lines; but that for graduations of one minute, or even to twenty seconds our rolled condensed brass is preferable.*

## SELECTION OF INSTRUMENTS.

The grades of instrumental work now called for from Engineers, being more numerous and varied than formerly, extending from that calling for most accurate results necessitating the most perfect and delicate instruments, to that where the question of results is to be considered along with the question of transportation, has called for a greater variety of instruments than heretofore.

While instruments of medium size and weight have a wide range of adaptability, we have found it impossible to supply the different requisites in the most satisfactory manner in the same instrument. We have therefore adopted as results of our experience a classification for Levels, Transits and other instruments, the basis of a heavy, medium and light instruments; for, though accuracy by no means follows as a certain result of weight, it is certainly true that weight limits size, and with same skill in proportioning size limits accuracy. The character of the work is the same in all our instruments,—the higher priced ones, in addition to size, have principally small additions to increase their efficiency, and such modification of construction to adapt them to their purposes.

We have placed in this edition the Variation and the Surveyor's Transit, omitted from our last because of inability to produce good work and compete in price with the cheaper class of these instruments. Numerous applications having obliged us to insert them, purchasers may rely upon their having the same quality of work as upon our larger instruments. They form an intermediate link between the Surveyor's Compass and the Engineer's Transit, and while we would advise to the County or other Surveyor the purchase of Engineer's Transit, they will find these instruments useful and reliable, if desired.

In choice of LEVELS we would advise, for ordinary RAIL-ROAD work, where quick working and large field are desired, our 17 inch Level.

For CITY work, or such Rail-roads as require greater than ordinary accuracy, our 18 inch or 20 inch Level.

For ordinary country service, or where a light instrument is especially desirable, our 15 inch Level.

In choice of TRANSITS for general RAIL-ROAD or Engineering purposes, our No. 6, with  $6\frac{1}{4}$  inches graduations.

For rough Rail-road or Engineering work, our No. 3 or 4; to stand extra rough usage, No. 4.

For ordinary town or city work, No. 6, with  $6\frac{1}{4}$  inches graduations.

For city work, where Engineer desires Transit of finest quality, our No. 7, with all improvements.

For such work as requires exceeding accuracy in angular measurements, the Repeating Circles.

For Tunnel and work where accuracy in producing straight line is desired, our No. 13.

For Mining purposes, our No. 10, with additions.

For Surveyors we would earnestly advise an instrument such as Engineer's or Surveyor's Transit, where the accuracy of reading of needle can be checked off.

For accurate work, requiring an extremely light instrument, our No. 10.

We offer this advice on selection, simply as an answer to numerous enquiries, and do not mean that none but those specified would answer purposes named. Thus we believe our No. 6, 6½ inches graduation, to be as fully competent for all conditions as any other instrument in the country outside of our selection; but there has grown up a demand for this classification of our work, and after giving sufficient details of our instruments, must leave it to Engineer to determine the characteristics of his business and judgment of our choice.

## ADJUSTMENTS.

Too little knowledge exists amongst Engineers as to principles which govern adjustment of instruments, in consequence of which many fear to touch these adjustments, and allow them to go for years untested, performing important work in which the results must necessarily be in error, or, at an expense and a loss of time sending long distances to instrument maker.

We have endeavored to so illustrate the general principles, that after their careful consideration the Engineer will never be at a loss to apply proper correction, will be enabled to test his instrument understandingly and adjust them confidently, without being confused in attempt to follow the almost unintelligible directions generally given.

A consideration of the principles of adjustments tells us that, independent of the verniers and of needle, (which consist in placing certain points in straight line, and perhaps should not be classed as adjustments) they all consist in placing certain parts either at right angles or parallel to each other.

Thus, the adjustment of Transit consists in making the plates, or which we here consider the same, the spirit levels, revolve at right angles to vertical centre of instrument; in making the axis upon which telescope turns, at right angles to same centre, or parallel with plates; and in placing the line of collimation at right angles to this last; and if we include the comparative position of web, it would be in placing the vertical web at right angles to this same axis.

Again, in the Level, the adjustment in like manner consists in placing the line of collimation and the line of level parallel to each other and at right angles to the vertical axis upon which instrument revolves.

In making these adjustments the spirit level acts an important part; but we have here chosen to consider it merely as means of making them, or of placing the instrument in position.

The general method made use of is that of reversions. Reversions double all errors and place them on opposite sides, so that if there is no difference after reversals there is no error; or if there is a difference, the mean between the two points indicates the amount of errors as well as the true point. *Every* adjustment may be set down as depending upon the method of *reversals*.

In the following directions, in which for purpose of thoroughness we shall include the centre pin and needle, we shall first give the *object* of adjustment and then the general method of performing it.



## OF THE TRANSIT.

The adjustment of Transit, disregarding for the present the needle and centre pin, are:—

1. The Levels.
2. The Standards.
3. The Telescope,  
And where the telescope has a level attached.
4. The Telescope Level,  
And where there is a vertical circle.
5. The Zero of Vertical Circle.

### OF LEVELS TO COMPASSES, TRANSITS, &c.

The *object* of this adjustment is to bring the levels in such position that the bubbles will remain in centre of tube in all positions of instrument, when the vertical axis of instrument is in a true vertical position, or in other words, to bring the "level" at right angles to vertical axis of instrument.

The *method* is to bring the bubble in centre of tube, then reversing the instrument on its vertical centre, the bubble in tube will pass over double the actual distance indicating its error—changing it half way back by adjusting nuts and half by levelling screws.

To *perform* adjustment, bring bubble in centre of level tube by means of levelling screws; turn instrument half way on its vertical centre. If the bubble moves to one end, bring it back half way, as nearly as can be estimated, by means of the capstan nuts or screws under the ends, and the remaining half by means of the instrument levelling screws. The trial should then be repeated by another turning half way round and similar correction.

If, as is general, there are two levels at right angles, it is preferable to adjust one approximately and then the other, as well as to turn the instrument as exactly half way round as possible.

Should one level be much out it is difficult to adjust other, as turning it more or less than half way causes it to partake of the error of the level which is out, and the adjuster will be making corrections for errors which do not exist, and placing his levels more out instead of in adjustment.

Where a circular or universal level is placed in line of the two straight ones, the operation is the same, excepting the adjustment is generally made by three small screws passing through the plate on which it is fastened.

When adjustment is completed by reversing in several positions upon one centre, the reversal should be tested upon the other centre or plate. If the centres are not true to each other, or the plates at right angles to both centres, the level on reversing on different plates will not remain in centre, and indicates an error which the Engineer cannot correct.

We suppose in this, as in other cases, the Engineer will readily perceive and understand the means provided in the instrument for making the necessary changes, and that he will not injure the threads of his screws and peril the permanency of his adjustments by overstraining, but in all cases bring nuts and screws to simply a firm bearing.

## OF THE STANDARDS.

The *object* of this adjustment is to bring the bearings upon which telescope revolves at right angles to vertical axis of instrument, in order that the telescope may move in a true vertical plane when this axis is truly vertical.

The *method* generally employed by us is to compare the line as described by motion of intersection of web upon any two marks, such as top and bottom of building, when instrument is in one position, with line described by same, when instrument and telescope are reversed.

Another method is to test the motion of intersection of web on a plummet string. This last is, however, more of a test upon accuracy of two adjustments, this and the levels, and on account of short distance at which a plummet line must be placed, in order to give sufficient vertical angle, and the unsteadiness of lower end of line, it is not regarded by us as the best. It is of advantage, however, to test by all methods.

In some of our instruments, intended especially to undergo rough usage, we do not place the means of making this adjustment upon them. Our method in this case is to take off bottom of one or other standard. The Engineer's best means in this case is to raise the lowest one by placing tin-foil or paper under same. This construction is not liable to change adjustment except through injury.

While in this adjustment it is as well to have instrument at level, it is not necessary. The adjustment can be as accurately performed in any other position, and it will be found most convenient to throw instrument into such position as to command well defined marks above and below.

To *perform* adjustment, select a building or other object which, with instrument at distance of at least 40 or 50 feet, will give a vertical range as great as instrument admits of observing. Any well defined mark or spot on top of high building will answer. Direct the intersection of cross-wires of telescope to this mark, clamping all plates and centres of instrument firmly, then depress telescope and select or make a mark where intersection of web strikes; reverse the instrument on centres, which will cause telescope to point the other way, and reverse telescope to former direction, bringing intersection of web to bear upon upper mark, then depress telescope to lower mark. Should it not correspond with this lower mark, a point half way between it and where the intersection now strikes is the correct line, and the adjustment should be so altered as to cause the telescope to travel on this line. As in other adjustments the reversals should be tried several times.

### ON LINE OF COLLIMATION.

This is generally termed the adjustment of cross-webs. The *object* is to bring the optical axis of telescope at right angles to the axis upon which telescope revolves. As the setting of the telescope on the axis must necessarily be quite accurately performed by the instrument maker, there is left for the Engineer only the bringing of the cross-web, by which the line of telescope is defined, into the line of collimation.

The *method* employed is, in principle, obtaining a straight line passing through centre of instrument, and comparing with it the line produced by a revolution of telescope on its axis. The two means generally employed are: first, by com-

paring the line given by a revolution of telescope on its axis, or by back and fore sight when axis is in one position with the line, as given by revolution of telescope, or back and fore sight when axis has been reversed. It is evident that with same back sight the reversal will give an error equal in amount, but on opposite sides, on the two fore sights; hence the true line is one from back sight passing through centre of instrument and a point midway between the two fore sights. The cross-web is then drawn over until it is one-fourth the distance between the two fore sights, or one-half the distance between the back sight and the proper line midway between the two fore sights.

It is a frequent error with Engineers to draw the cross-webs over one-half distance instead of one-fourth. The reason the correction should be only one-fourth is because of its doubling itself,—equally on the fore sight as on the back.

The second method consists in producing a straight line by a single fore sight marking two ends and an intermediate point, placing the instrument on the intermediate point and adjusting to the two ends.

To perform adjustment by first method, set the intersection of cross-web upon back sight, stake or other mark, and clamping plates and centres, revolve telescope on its axis; mark point where the intersection strikes. Reverse instrument on its vertical axis, bring intersection to bear on back sight, and revolve telescope on its axis, and mark this fore sight along side of former one.

Measure and mark midway between these two, also midway between this last and the last fore sight. The first midway mark is the one on straight line passing through back sight and centre of instrument. The second, or one one-fourth between the two fore sights, is the one to which the cross-web of telescope should be made to correspond, in order to bring the web to proper place. Therefore, without changing instrument, bring the intersection of cross-webs, by means of the capstan screws, to act upon this last midway mark. This done, it is advisable to remove the marks except the one midway between the two fore sights. If the adjustment has been correctly made the intersection of webs will strike upon the back and fore sights alike when instrument is reversed on centre.

If, as may often happen, the back and fore sights are inaccessible, the difference of one-fourth must be made by estimate, and perfect adjustment obtained by repeated trials.

In making these adjustments the back and fore sights should, if possible, be equal, to avoid changing focus of telescope; but, as a test after adjustment is complete, the telescope should be thrown out or in, and then brought to its proper place and adjustment tested to ascertain if this motion of telescope causes any change in line of sight. We would not advise the length of sights to exceed 300 feet; it will be found a closer adjustment can be made at this than at longer distances.

To perform adjustment by second method, place points under centre of instrument—one at about 500 feet distant, and by instrument, one in line midway between. Set the instrument over centre point, bring intersection of web upon one of the end points, and revolve telescope upon axis and mark where it strikes opposite the other end point; measure and mark midway between these two points, and without changing instrument, move cross-web upon this midway mark. Then test by reversing instrument upon its vertical axis, sighting at one extremity and revolving telescope upon its axis upon the other, as before.

Previous or subsequent to this adjustment, as Engineer may prefer, the cross-web should be set vertical, so that it will remain upon object as telescope is raised or depressed at upper or lower edge. The most convenient way is to sight to object on upper edge, and raise telescope until it comes in lower edge of field. If web does not strike, loosen web screws, and turn slightly either by hand or by tapping slightly on screws.

If the web is set before performing the last adjustment it must be examined at the close, as adjusting is liable to throw it out.

#### OF LEVEL TO TELESCOPE.

The *object* is to bring level parallel to horizontal optical axis of telescope.

The *method* by which it is performed depends upon principle, that from any point equal angles of elevation or depression for equal distances will result in equal difference of elevation or depression from this point, and that two points equally above or below any other point must be of equal height or level with each other. Two points on a level are thus obtained, and if instrument is set over one at an ascertained height, the level line as given by instrument, if in adjustment, will strike at same height above other, or the difference of readings will measure amount of error.

To perform adjustment the instrument is carefully levelled, equal distances measured in line on opposite sides, and with level on telescope in centre of tube stakes A and B, driven to an equal reading below instrument. These two must then necessarily be upon a level with each other. The instrument is then moved say 10 feet beyond one of the stakes, say A, in line with other; a rod reading taken with level upon A, and this reading with correction, as below, held on B when cross-web, or level altered so as to strike the rod on B.

If the instrument was directly over A, and its height above A ascertained, it would only be necessary to hold the same height or reading on B; but as this height cannot be correctly ascertained except by reading through instrument, it becomes necessary to move away from stake, and in observation this distance partakes of error of instrument and needs the correction, which is proportionate to distance of instrument and stakes from each other.

The rule for correction, when the instrument is beyond stakes is:

*Divide the difference of readings on stakes, by distance between stakes, and multiply by distance from instrument to further stake.*

Thus, if difference of readings is 2 feet, distance between stake 200 feet, and distance of instrument beyond 10 feet, then

$$\frac{2}{200} \times 210 = 2.1, \text{ amount of correction.}$$

Should the instrument be placed *between* the stakes, in place of beyond, double the error of distance from instrument to nearest stake takes effect, and the rule becomes:

*Divide the difference of readings on stakes, by the difference of distances from instrument to each stake, and multiply by distance of instrument from furthest stake.*

Thus, distances same as before, except instrument being placed between stakes, 10 feet from one, then the difference of readings would be 1.8, and

$$\frac{1.8}{190 - 10} \times 190 = 1.9, \text{ amount of correction.}$$



Though incorrect in theory, the adjustment may be made by repeated trials without correction, the error becoming less each time until it becomes inappreciable, especially if respective distances from instrument to stakes are made with a great disproportion to each other.

The object being to make the line of sight parallel to the line of the level, theoretically either the cross-web or bubble ends may be changed; but it is preferable to bring the horizontal web in middle of field of telescope in adjustment for collimation, and to perform this adjustment by moving the bubble so as not to disturb the web.

#### OF ZERO OF VERTICAL CIRCLE.

The *object* is to bring zero of vernier circle to agree when the level is in true level line and the vertical axis of instrument in a true vertical one, or that when either axis or level are correct the other shall be at right angles to it.

The *method* is by bringing level on middle and reversing on vertical centre. The amount the level is out on reversing indicates double error, which must be equally corrected on the bubble by its screws and on centre by levelling screws, and vernier then set to agree with zero of circle.

To *perform* adjustment, level instrument by ordinary levels, then bring the bubble of telescope level to centre and reverse on vertical centre. Correct half of amount of disturbance of bubble by means of tangent or opposing screws and other half by means of parallel plate screws. When the instrument is so the bubble remains stationary in reversing instrument on centres, the zero's vernier must be shifted to read zero, if possible, if not, the reading noticed as a constant to be added or subtracted.

As it is seldom we attach a full vertical circle to our instruments, using our movable vertical arc, this last adjustment is not required of them.

### OF THE LEVEL INSTRUMENT.

The main objects in adjustment of Level instrument are to place the line of collimation parallel to level line, and the vertical centre at right angles thereto.

The adjustments are:

1. Telescope or Line of Collimation.
2. Of the Level.
3. Of Bar or Y's, which in reality is the adjustment of relative position of the telescope and level to vertical centre.

#### 1.—OF TELESCOPE OR LINE OF COLLIMATION.

The *object* of this adjustment is to bring the cross-web on line of collimation.

The *method* by which it is performed is by revolving upon the telescope collars and bringing the cross-web into centre of revolution.

To *perform* it the telescope is brought to bear upon a distant object, plainly visible, by means of the levelling screws, instrument clamped, and telescope is then revolved half way round on the collars; the distance the cross-web strikes

from the point is double error, and the web must be brought half way over by means of capstan head screws, moving the web in opposite way to which it apparently has to go.

The operation may be made with the vertical and horizontal webs at same time, or each may be adjusted separate. When adjusted for a long distance they should be tested on short one, say 15 feet.\*

#### 2.—OF LEVEL TUBE.

The *object* of this adjustment, after first is performed, is to place the level in such position that when bubble is in centre, a tangent to the curve at its highest point will be parallel to the line of collimation.†

The adjustment is, in fact, a combination of two—of the main one and of the side adjustment to tube—that the axis of telescope and of level shall be on one vertical plane. The former cannot be performed while the latter is out, nor can the latter while the first is greatly in error. Means of making the amount of side motion equal on each side would allow the side adjustment first, but in absence of this the two must be made together, as it were, until approximately correct, when the error of other will not materially affect side adjustment.

The *method* employed is to bring the level by reversals parallel to Y bearings, and in vertical plane by revolving a small arc on either side.

To *perform* it, clamp instrument so telescope will be over one set of screws. Bring bubble in centre by levelling screws, then reverse telescope and level end for end. The amount the bubble moves is double error, one half of which is to be corrected by levelling screws and one half by capstan screws under end of bubble tube. Then revolve the telescope on its bearings 20 or 25 degrees on each side, keeping the motion on each side alike, throwing tube upwards. If bubble runs towards either end the bubble must be drawn over by opposite side screw until on either side the motion is alike, when the first adjustment must be again tested and the two gone over alternately.‡

#### 3.—OF THE BAR OR Y'S.

The *object* of this is to bring the line of collimation and of level at right angles to vertical axis. It also serves as a test upon the first and second adjustments, determining the equality in size of collars by which these adjustments are made.

\* If adjustment does not hold good, the slide of telescope does not work parallel with line of collimation and the only remedy is in instrument maker. The means of adjustment to the slide to obviate its error we have always found a greater source of disturbance than of benefit, the constant working of slide upon movable adjusting ring loosens the screws, and the tube has nothing whatever but a loose ring to direct its motion.

† This adjustment does not follow because when level is reversed, the bubble remains in centre, an error into which we believe all the best books have fallen. We use the Y bearings, so to speak as a plane or point, and whilst reversals make certain the level is parallel thereto, it does determine the same of collimation, as the collars of telescope upon which revolution is made may be of unequal size and not affect that adjustment. We would then have the line of collimation out of parallelism. A test for this is found in a combination of the second and third adjustments as described hereafter.

‡ When the side adjustment is correct the telescope can be thrown sideways without altering the position of bubble. Should it travel towards the same end on either side the adjustment will not correct it—the tube is conical in place of being cylindrical. It is not necessary the level should be thrown much sideways, only as much as it is likely to be accidentally thrown out of line in reversing telescope end for end.

The *method* is by comparing position of bubble in reversals upon vertical centre. To *perform* it, level the instrument over opposite screws and reverse on centre. The amount bubble moves is double error, one half to be corrected by the nuts at end of bar, other by levelling screws. After this is adjusted over the four levelling screws that the bubble remain in centre in all positions, *reverse the telescope on F's*, as in second adjustment, and then reverse on vertical centre. If adjustment does not remain, the collars in telescope are of different size, and adjustment No. 2 is not perfect. The only remedy is to have collars ground down to same size.

Adjustments No. 1 and 2 affect the correctness of instrument. No. 3, however, does not; it is a convenience as saving the constant levelling when it is not in adjustment; but, independent of its being made in order to test the combined effects of No. 1 and 2, the accuracy of instrument is not affected by it.

## THE SURVEYOR'S COMPASS.

Independent of needle and centre pin the adjustments of Surveyor's Compass consist of:

1. Of the Levels.
2. Of the Sights.

### 1.—OF THE LEVELS.

This is same as in the adjustment described for Transit instrument.

### 2.—OF THE SIGHTS.

The *object* of this is to bring slit or cross hairs in a vertical plane when instrument is level, or bring the two, perpendicular to each other.

The *method* employed is similar to that for standards of transit, and consists in making the line strike the same two points above and below before and after reversals on centre.

To *perform* it bring compass level, and with eye near bottom of nearest sight bring in range through the upper and lower part of opposite sight two points, or, if convenient, some vertical mark. Then change eye to top of nearest sight, and if it strikes same points the sight nearest to eye is in adjustment. Reverse the ends of compass and perform the same on other sight.

A plummet line, so suspended as to be free from action of wind, if can be had with a long range and sufficient vertical angle, forms a good test for this adjustment, as in adjustment for vertical motion of transit.

If sights should prove incorrect, one side should be filed down to throw them over. This adjustment is not properly one belonging to Surveyor, but to instrument maker. Once made it should not get out by ordinary usage; but the sights and plates of compass are so frequently subject to rough usage and liable to be thrown out, and so much of accuracy of ranging depends upon it, that it is advisable the Surveyor should test it often. A common cause of injury to this is bending of plates or sights by a wrench, and if Surveyor is careful he will be able to adjust when out, and he has no other means, by screwing sights firmly down, and holding both at once bending in direction they need.

## BURT'S SOLAR COMPASS.

There are several adjustments of the Solar Compass required of the manufacturer which are necessary to perfection of instrument, but which the Surveyor cannot and is not called upon to perform. The adjustments of completion of instrument are:

1. The Levels.
2. The Silver Plates of Declination Arc.
3. The Zero of Declination Arc.
4. The Zero of Latitude Arc.
5. Coincidence with Meridian of Zero on Plates.

We have followed in this enumeration the order as given by Mr. Burt. It is very nearly the same as now used by us, and is perhaps more familiar to Surveyors.

### 1.—OF LEVELS.

This is same as described under head of Transit instrument.

### 2.—OF SILVER PLATES OF DECLINATION ARC.

The *object* of this adjustment is to ensure line of the image as thrown by one lens shall be parallel to that thrown by other. Its necessity arises from the employment of same arc for north and south declinations and consequent use of two lenses.

The *method* consists in bringing the silver plates in such position that the image of sun will fall between the equatorial lines when the declination arm is reversed on upper and lower edges, by which each line of lenses is brought parallel to sides of arm and consequently parallel to each other.

The adjustment requires practice for proficiency, but is exceedingly important and its frequent examination should not be neglected. Upon it depends the accuracy of declination zero and of all declination readings.

To *perform* adjustment unscrew declination arm and attach in its place the adjuster. Bring instrument approximately to its place as if to make observation, and placing the declination arm on the adjuster bring sun's image to fall between the lines of silver plates, then reverse the declination arm so as to bring upper edge below, carefully, so as not to move any other part of instrument. If this plate is in adjustment the sun's image will fall between lines as before, if not in adjustment it will fall a distance away equal to double the error, and silver plates must be moved half way. For this purpose the holes in silver plate are large, to admit of motion when the small screws are loosened. When one silver plate is corrected the other is to be likewise adjusted. When both are adjusted a reversal from end to end will test the parallelism of blocks which hold the lenses.



## 3.—OF ZERO OF DECLINATION ARC.

The *object* of adjustment is to bring the declination arm, when at zero, to a right angle with the polar axis.

The *method* consists simply in raising or lowering the declination arm until it is in such position that the image of sun strikes upon the lines of silver plates when reversed on polar axis.

To *perform* it set zeros of declination arm and arc together, and by means of level screws of instrument, or by motion of plates, bring sun's image between lines of silver plate; then reverse arc on polar axis. If zero is correct the image will fall upon the other silver plate, if not, bring the image to do so by means of tangent screw and the reading will be double error.

The vernier can be shifted to read correct by loosening the screws which fasten it.

## 4.—ZERO OF LATITUDE ARC.

The most imperfect part of the Solar, as far as adjustment and corrections are concerned, is the latitude arc. From construction of instrument and the manner in which it becomes necessary to attach the arc, it is impossible to test either whether the arc is truly centered to the axis running through centres on hour circle, or whether the zero starts from correct point. Fortunately neither of these affect the correctness of the work on surveying to any extent. In all work the latitude, *as given by instrument*, should invariably be used; all parts will then be in proper position and no error be to lines run. It may happen that in long distances of northing or southing the difference of latitude as given by Solar may vary from correct differences deduced from measurement, and yet the instrument give in all cases proper lines when latitude is kept tested. The error arises from eccentricity, and as there is no known corrective the Surveyor should be extremely careful to test latitude at every 5 or 10 degrees of difference.

The *method* consists first, in observations north and south of the Equator, or one observation on Sun and another on North Star. In one case the result is given too high and the other too low by the amount of error, so that the mean of the two is correct. The correction is necessary in determining the exact latitude of the place, but not so important in use of instrument.

Another method where latitude is known, and one which is generally used, is observing the sun at noon and bringing the latitude arc so that the sun's image shall fall between equatorial lines when at its highest point or noon.

To *perform* adjustment by first method is simply making the two observations, one on the sun and other on star.

To *perform* by second method, the instrument should be set up about ten minutes before apparent noon, with declination and refraction set off on declination arc, and the latitude arc raised or lowered by tangent screw, until by motion of the horizontal plate and declination arc the sun is brought between the equatorial lines. As sun approaches noon it will be found necessary to raise latitude arc, as well as move the horizontal plates and declination arc, in order to keep sun's image between lines,—and will be highest at noon. When at highest point the latitude should be read, and if it differs from known latitude the vernier should be shifted by loosening screws.

Another method employed to find zero of latitude arc is to make observation in morning with latitude as given by instrument, and place meridian mark; then with same reading of latitude make observation in afternoon. The meridian for this purpose is half way between these two, and latitude arc should be changed so as to bring the instrument to read on this meridian. In place of meridian the bearing of any object may be taken.

This is a speedy method of testing and getting latitude. It is not an effectual test, for it partakes of any error existing in the polar axis and the axis of latitude arc, not being at right angles, but has the advantage of dividing the errors; and as finding the latitude by regular method of observation at noon may be interfered with by a slight cloud at the moment, it is frequently used. Whenever possible, however, the noon method should be used.

## 5.—COINCIDENCE OF MERIDIAN WITH ZERO OF PLATES.

The *object* is to ascertain whether the sights (or telescope) and the vernier have been placed properly with each other.

The *method* consists in bringing the sights (or telescope) on line at right angles with polar axis when same is made horizontal, and setting the verniers to zero; or the reverse, of setting the verniers to zero and bring the sights (or telescope) at right angles to polar axis.

To *perform* it, release the latitude arc and raise it until the polar axis is horizontal; place equatorial sights on the lens blocks; bring the declination arc to zero, and sight on distant object; then bring sights (or telescope) on same object, and the vernier of main plates should read zero.

The correction is made by either, by moving verniers of plates to zero, or by shifting sights so they shall bear upon same object as equatorial sights when the zero of plates coincide.

Another and simpler method, where a meridian line is established or can be obtained is, after making certain previous adjustments correct, to compare the line as given by a compass and shift vernier or sights over to suit the same.

Besides the above, Burt gives an adjustment, which he calls the fourth, to bring polar axis at a right angle with the axis of latitude arc. We are satisfied that the Surveyor cannot make this adjustment, and believe Burt's method to be liable to an intermediate mechanical error, which the adjustment does not provide for, and which may be the cause of some inaccuracy in results. We have provided within the few years past a severe test for this, and believe our instruments as now constructed to be more efficient on this account.

The *object* of the adjustment is to bring the polar axis at right angles to axis of latitude arc, so that the readings given on each side of meridian, or on the morning and afternoon, may be alike. The failure of solar most generally occurs upon this point, and the solar is the nearer perfect as it determines the lines of the morning and afternoon alike.

## OF NEEDLE AND CENTRE PIN,

COMMON TO ALL NEEDLE INSTRUMENTS.

These in reality constitute two adjustments, but, as in the operation, they are dependant upon each other, as one cannot be made correct unless the other is either correct or its error ascertained, it is necessary to consider them together.

The *object* is to bring the two ends of the needle and its centre in the same straight line, and the centre pin in the centre of graduations. Otherwise it is to bring these various parts so that when in any position one end of needle has a certain reading the reading of other end shall be 180 degrees different.

The *methods* adopted are two,—first by bringing one end of needle, say the N, to reading on some one point, say N zero of compass, and noting the reading of south end; then reversing the compass, and after bringing the N point of needle to S zero of compass, to note the reading of south end and compare this with former readings. It is evident that as the needle remains stationary, if the reading of south end of needle has changed left or right by the reversal, the change must be due to the moving point, which is the centre pin.

If, however, after reversal the reading of south end remains as before to the left or right of zero, the error must be due to stationary part, the needle, as the movement of reversal has produced no motion in centre pin, this must therefore be in centre of graduation. Where a change has taken place in readings, and they are not the same in amount, both needle and centre pin are out, the one which is most out being determined in accordance with above rules.

The *other method* rests upon the mathematical property, that as every point within a circle lies in some diameter passing through point and the centre, there must be one position of centre pin in which it is in adjustment or in line joining the centre of graduation and two opposite points of ring. The method here then is to ascertain by trial the point of the compass on which, by reversal, the opposite end of needle always reads to same side and same amount, showing the error in this place to be in needle alone. The adjustment of needle is then made perfect first, and complete adjustment of centre pin afterwards.

The advantage of this last method is, that it becomes necessary to pay attention to but one adjustment at a time, whereas by the first it is necessary to consider the effects of the two combined.

To *perform* adjustment by first method, level the instrument; bring the N end of needle to N zero point of compass, and read the S end of needle; reverse the compass so that the N needle reads the S zero of compass, and note the readings of S end of needle. If in *both* cases the readings are 180 degrees apart the instrument is in adjustment.

If the readings are on opposite sides, left or right of the zero, and alike in amount, the centre pin is out of adjustment, and needs bending over one-fourth the amount of the error, or so as to bring reading half way between the former readings, or at zero of compass.

The examination should be made at other parts of compass, so as to test in at least eight different points, to ensure correct centring of centre pin.

If the readings are on the same side and of same amount the needle is out, and should be bent over until the ends are bent one-half of the error, or until two ends read the two opposite zeros.

If the readings of error are unlike in amount it indicates an error in both needle and centre pin. The readings remaining on same side and unequal in amount, indicating the greatest error, lies in the needle, while readings changing in position and in amount, indicating the greatest error, lies in the centre pin.

In the *second* method the difference of readings should always come upon same side and be of same amount. The adjustment of needle is then completed by bending. Should, when the adjustment becomes nearer, the readings come upon different sides, it indicates the line of trial is not that in which centre pin is in adjustment, and the trial points must be shifted one side or other. After adjustment of needle the centre pin is adjusted as described in first operation.

In speaking of the sides we are to be understood as meaning the *positive* sides, viz.: left or right of the adjuster, the east and west sides of compass changing their position with reversals.

The bending of centre pin is done by a small brass lever having an opening, which is placed over centre pin, about one-half way up to point, and a slight pressure applied to end of lever.

The bending of needle is done by holding that side of needle to which it is to be bent against the thumb and forefinger of the left hand, with thumb and forefinger on either side of cap, less than an inch from it, then placing the thumb and forefinger of right hand against the opposite side of needle, beyond those of left hand, and pressing the needle slightly against them.

The operation of adjusting a needle and centre pin is one that requires patience, care, skill and time. It can seldom be performed properly by other than the experienced adjuster of the instrument manufactory; and except in cases of actual necessity, it is better the Surveyor or Engineer should not attempt it. We place it here because, though very seldom, the necessity does sometimes occur, and because it is advisable they should be understood by the user of instrument. In cases where the centre pin has by accident the point broken, or become dulled to such an extent as to make its removal from instrument a necessity, the directions may be of service to Surveyor.

In adjusting, the ring which covers the glass should be placed lightly in its place, pressed slightly down; the needle should be allowed to come to its bearing of its own accord.

Directions have been given in making the adjustment to hold needle in position by a splinter or wire. On trial it will be found impossible to give to the needle and centre pin by these means that perfect adjustment necessary.



## IMPROVEMENTS.

*It is a gratification to us to be enabled to say to our friends, that not only is the invention and introduction of ENGINEER'S TRANSIT due to our house, but likewise, in our belief, we are justly entitled to claim that every actual improvement, in either Transit or Level, as well as other instruments, have originated with us.*

### GRADIENTER.

This important addition to our Transit instrument measures, with accuracy, and economy of labor and time,

- 1st, Gradients,
- 2d, Distances,
- 3d, Actual differences of Level.

The ordinary Transit simply measures the angular position, as referred to a certain line; the Gradienter addition determines every other condition necessary to establishing the actual position of any point.

The addition adds very little to weight of plain instrument—nothing whatever where level is already placed on, and its peculiar advantage consists in no manner interfering with the use of instrument as a Transit.

In its construction, a clamping arm extends downwards from axle upon which telescope revolves, and is forked at lower extremity to embrace a micrometer headed nut. This nut moves along a screw, accurately cut upon our straight line engine, making a certain number of revolutions to the hundredth of a foot. The head of screw is graduated into one hundred parts, and attached is a zero edge for reading graduations.

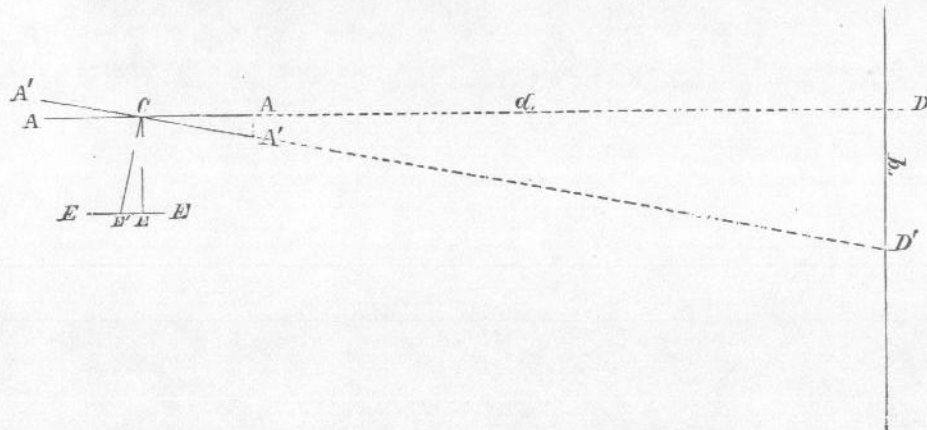

If the line A A represents the centre line or optical axis of telescope, when level, and which produced strikes a rod at D; C E, the perpendicular or clamp piece of Gradienter; and E E the micrometer screw parallel to telescope or A D:—then, when we clamp Gradienter, and move the micrometer screw along E E, the telescope and its produced line will also move the same angular distance, the produced line striking at D'.

It is evident that C E E' and C D D' are similar triangles, and if we know positive values on one, and relative values of both, we can determine other values.

Thus, if one revolution of micrometer screw moves Gradienter with a proportion of one foot perpendicular to one hundred feet horizontal, then the telescope would be elevated (or depressed) as to indicate a difference of one foot on D D' placed one hundred feet off; and two revolutions indicate an elevation or depression of two feet in the hundred feet. Hence, the number of revolutions, and parts of a revolution, as indicated by graduations on the screw head, measures the grade from the level,—not in terms of arc, but in measures of base.

As the proportion of screw is such that a full revolution gives one foot vertical in a distance of 100 feet horizontal, when the motion of telescope measures this foot, it necessarily follows the rod must be 100 feet distant; or if telescope measures 1.50 feet, the rod must be 150 feet distant.

Or if points D D' are at a fixed distance from each other, so as to form a base, and the Gradienter is moved that the micrometer head travels as to bring line of sight from D to D', then is given the similar sides D D' and E E', and their proportional value to other sides, from which C D or distance is known.

It will thus be seen how simple are the principles upon which Gradienter depends. For its use, we give following simple

### DIRECTIONS

where the screw and micrometer head are so arranged as one full revolution, or 100 graduations gives proportion of one foot vertical to 100 feet horizontal.

#### TO RUN A CERTAIN GRADIENT.

*Bring Telescope level by means of milled head; then noting reading, continue motion of milled head one revolution and part thereof for each foot and part thereof, of foot per hundred of your desired gradient.*

Thus to set off gradient of 0.5 foot per 100 feet, move micrometer milled head 50 graduations from the level.

To set off 2.25 foot per 100 feet, move 2 revolutions and 25 graduations.

#### TO MEASURE A GRADIENT.

*Bring Telescope level, and note reading as before; then turn micrometer head until telescope line strikes the target or other object; the number of revolutions, and parts of a revolution, indicate the feet and parts of feet per hundred of gradient.*

Thus 1.40, or 1 revolution and 40 graduations, indicate 1.40 foot per 100 feet; 2.50, or 2 revolutions and 50 graduations, indicate 2.50 foot per 100 feet.

#### TO MEASURE DISTANCES.

Performed by two methods.

1st, By use of usual graduated rod. *By noting distances on rod graduated in usual style, passed over by one revolution of micrometer head.*

Thus, if one revolution of micrometer head passes the reading by the cross web of telescope from 5.00 ft. to 6.27—difference 1.27, the distance is 127 feet; if from 4.50 to 6.78—difference 2.28, distance 228 feet.

It is not necessary the operation should be confined to a single revolution of head, but there may be made as many as desirable. Thus, as above, the first reading 5.00, 3 revolutions gives 8.81—difference 3.81; divided by 3, number of revolutions, 127. Again, first reading 4.50, 2 revolutions give 9.06—difference 5.56; divided by 2, number of revolutions, 228 feet.

2d, By having an ascertained base, as two targets or other marks placed upon a rod, at any desired distance apart. *Bring telescope on one target or mark, note reading, and turn micrometer head until it strikes other; the difference in readings or number of graduations passed over by micrometer head, divided into base and multiplied by 100, gives distance.*

If in previous figures we denote  $D D'$ , on this case, our base by  $b$ ;  $C D$  the distance by  $d$ ; number of graduations passed over by  $n$ ; then we obtain as formula,

$$d = \frac{b}{n}$$

OR, DISTANCE EQUALS BASE, DIVIDED BY NUMBER OF GRADUATIONS.

As the graduations are hundredths of a whole revolution, it is necessary to multiply result by 100 to bring it to feet.

Thus, targets are placed 6 feet apart, number of graduations passed over are 250, or 2 revolutions, 50 graduations; then

$$\frac{600}{250} = 2.40 \times 100 = 240 \text{ feet.}$$

Targets 8 feet apart, graduations 315,

$$\frac{800}{315} = 2.539 \times 100 = 253.9 \text{ feet.}$$

The advantages of this last method consists,

1st, In the sights being taken on targets or other prominent marks, more plainly visible than figures or graduations on a rod, by which means a distance of at least three times as great can be taken as where it is necessary to read the figures; or same distance can be taken (except short distances, where figures are very distinct) with three times the comparative accuracy.

2d, The base can be changed as desired, and made to suit the nature of work and character of ground.

It is not necessary in this method to use a graduated rod; any two marks at ascertained distance apart answer equally as well.

In previous description we have supposed the fineness of screw to be such as to give a ratio of one foot vertical to 100 feet horizontal. We have deemed it preferable, in our larger instruments, to make screw finer, as giving more sensitive motion, and have made it to have ratio of 0.5 foot vertical to 100 feet horizontal. The former rules should then be modified as follows:

#### TO RUN CERTAIN GRADIENT.

*Turn micrometer head, double the number of graduations of micrometer head that is wanted in feet, per hundred.*

Thus, wanted 1.7 ft. per 100, turn  $1.7 \times 2 = 3.40$ .

#### TO MEASURE A GRADIENT.

*Divide the number of graduations of micrometer head by 2, to obtain ratio per hundred.*

Thus, 280 graduations,  $\frac{280}{2} = 1.40$  foot per 100.

#### TO MEASURE DISTANCES.

1st, By use of usual graduations on rod. *Move double number of revolutions.*

Thus, two revolutions give 2.60 on rod; distance equals 260 feet.

2d, By ascertained base.

Change formula into  $d = \frac{2b}{n}$ ;

OR DISTANCE EQUALS TWICE THE BASE, DIVIDED BY THE NUMBER OF GRADUATIONS

Thus, base 6 feet, graduations 500; distance 240 feet.

In use of Gradienter, as in use of every instrument to which a screw movement is attached, it is preferable to set micrometer head somewhat back, and bring it up to readings in direction in which movement is to be made. Though, perhaps unnecessary, it is a precaution that is always advisable.

The utility of Gradienter in running of grades on rail-road or other work, or in measuring gradients on preliminary or location, are evident to any engineer.

To illustrate its benefits in a general way, suppose the Engineer to desire a position of point, not only as regards alignment, but also as to distance, grade and difference of level.

He sends rodman to point, with target (fixed, if desired, at height of instrument), and with another target, or other plain mark, placed at, say 6 feet apart from first. He brings telescope level by micrometer head, and from this raises or depresses telescope, by micrometer, until it strikes first target. His readings then give him his gradient. He then makes a full revolution (or two or more if desired), and reads distance on his rods; or, he uses base on rod, and reads the number of graduations passed over, and thus obtains distance; or again, uses both methods, one to check other. Having distance and gradient, he multiplies them together, and obtains difference of level.

EXAMPLE.—Suppose, with screw giving ratio of 1 vertical to 100 horizontal, the observations are:

From level he depresses	283 graduations.
1 turn of screw gives	310 feet on rod.
Motion over base of 6 feet gives	193 graduations.
Then, 1.92, divided into 6, gives	310.1.
Results, therefore, gradient,	2.83 ft. per 100 ft.
Distance,	310 ft. by reading.
Or more accurate by base,	310.1.
Difference of level, $2.83 \times 310$	8.773.

With screw giving ratio of 0.5 ft. per 100 feet, the observations would have been—

From level, grade	5.66 graduations.
2 turns of screw give	310 ft. on rod.
And base 6 feet,	286 graduations.

No other instrument in practical use accomplishes the same results, viz., measurement of distances, grade and differences of level. For the measurement of distances we believe it preferable to the stadia wires. As a measure of comparison we generally place fixed stadia wires in telescope. As compared with stadia it has several advantages; the line of sight is in all cases directly in optical axis of telescope, being unaffected by want of flatness in the field, a



source of inaccuracy and great objection to the stadia; the measurements are made from centre of instrument direct, while in stadia measurements it is claimed allowance must be made for focal distances.

A great advantage in favor of Gradienter lies in the inability to use ordinary stadia wires at a distance beyond where the figures on rod are plainly visible,—the setting of targets in use of stadia is so slow, and so difficult an operation, as to forbid its general use, while the reading of hundredths of a rod, at any great distance, is an impossibility. The Gradienter, on contrary, in use of base system, makes the sights to targets or other marks which can be made, as distinct as needed. Not only this, but the base on Gradienter can be altered—made large or small—to suit character of work desired.

That property of the Gradienter, by which all that is positively required for its use, is to know the simple distance of marks or targets apart, is a remarkable illustration of merits of Gradienter. Using this distance as a base and measuring distance by micrometer screw,—WITHOUT USE OF GRADUATED ROD, with nothing but the knowledge of this distance of targets—then follows:

The measurement of Grade.  
 “ “ of Distance,  
 “ “ of difference of Level.

It is not even necessary to *know this distance at the time*. In case of emergency two marks may be placed upon a temporary rod, the observation made and distance of targets obtained afterwards.

The form of Gradienter, of German origin, where the micrometer screw is placed under the end of telescope, entirely prevents the use of instrument as a Transit, producing an instrument which the Engineers of this country look upon with especial disfavor.

With advantages enumerated, taken in connection with its adding nothing to weight or complexity of Transit with level to telescope, we feel confidence in recommending to favor of profession Young's Gradienter.

### EYE PIECE.\*

The Improved Eye Piece adjusts the focus to web with great precision and smoothness. It is so made that the eye piece does not turn as it moves out and back, but moves in same straight line, preventing rotation of eye piece upon image.

An incorrect focusing of eye piece produces parallax in sighting, throwing object to one side or other of web. An accurating focusing of eye piece is of as much importance as power of telescope; and as power increases it is the more difficult to focus with the usual slide—with extreme high power almost impossible—hence, importance of this improvement.

\*The original adjustable eye piece we believe to have been made by Messrs. Kubitler & Seelhorst. We believe our method to be an improvement.

### IMPROVED TELESCOPE OR WEB FASTENER.

In the usual construction of the Level instrument, even when in perfect adjustment, an observation taken other than at immediate intersection of cross web, tends to produce error, from the rotation of telescope in Y bearings throwing all other parts of horizontal web above or below the true level line. The bringing to exact intersection on rod is tedious,—the examination and correction of horizontal web each time still more so; while, unless one of these are resorted to, error is almost certain, and this error is the great source of inaccuracies in operation of levelling.

To obviate these errors, we fasten the telescope on the Y's so as to prevent any rotation. Observations can be made at any portion of the field of view, equally as well as the centre. Another advantage consists in the certainty with which the Engineer can regulate the perpendicularity of his rod.

The attachment interferes in no manner with adjustment of instrument. It has met with universal approbation wherever used.

### SLIDE PROTECTOR.

The motion of tube or slide of object glass upon main telescope tube is apt in time to wear, one or both sufficient to produce a shake, the result of which is to throw line of sight to one side or other in focusing the telescope. Inability to wear a long time without shake is a sign of a poorly constructed instrument; but even in best constructed the dirt, grit, &c., which adheres to slide and is carried into tube by it, is a cause of more rapid wearing, or a greater inconvenience at the time, be a fretting of the slides. Rain and moisture is also carried in, making air inside of tube damp and affecting the performance of telescope.

As a preventive we have added our SLIDE PROTECTOR,—a thin tube or sleeve covering the slide and moving with it, so that neither dust nor dirt can reach it.

The attachment preserves the slide, upon which perfection of collimation depends, in good condition for a much longer time.

### TANGENT.

The Tangent with double nut, or a follower, and spring between the two in such manner as to keep them apart, is an English invention.

It forms a desirable method, whereby the wear of a screw is constantly taken up and dead motion prevented.

We have improved upon this by an addition, so covering the tangent as to prevent dust, dirt, &c., from reaching it.

There are other points of improvement in our tangent screw, such as length of attachment, by which the screw is kept acting more nearly at a tangent.

### ATTACHMENT TO TRIPOD.

Experience has proven many an error, perhaps inexplicable to the Engineer, has occurred from the fastening to tripod slipping slightly in manipulating instrument. All methods of fastening which have an intermediate plate between bottom of level screws and plate of tripod, into which legs fit, are liable to this fault. In our improvement we have followed the practice of German and French, who allow no intermediate plate. Though the end accomplished is same, the method is different. Their method allows only the use of three levelling screws. Ours consists simply in screwing on "half ball," in such manner that when instrument is levelled the four level screws form four clamping screws, direct on tripod head, to prevent motion.

It also serves to lighten instrument.

The careful attention of Engineer is called to the method of attaching instrument, where with ordinary attachments he will be likely to find a source of error he little suspected, especially after working with his instrument greater part of day.

### PATENT SHIFTING TRIPOD.

(Patented July 13, 1858.)

By simply loosening the level screws, the instrument can be shifted a small distance in any direction, after the instrument has been set approximately.

The great convenience of this is evident to every Engineer. It is preferable to all imitations, inasmuch as it may be called self-acting, the wire levelling up screws to ordinary tension holds instrument firmly in its place.

### YOUNG'S IMPROVED TELESCOPE.

(Patented by John W. Nystrom and Alfred Young.)

The several years of consideration of our Improved Telescope since date of our patent, has enabled us to so perfect it as with confidence to request attention of Civil Engineers to the valuable modification of Engineering Instruments.

This Telescope, the joint invention of Mr. John W. Nystrom, the well known scientist (the inventor of Nystrom's Calculator, and other improvements, and the author of standard mathematical and mechanical works), and ourselves, combines the following advantages, when compared with ordinary constructed Telescopes:

**CLEARER FIELD, WITH MORE LIGHT;** an important gain, as any increase of power is attended with loss of light, or increased darkness and cloudiness of the object; and the high power to which Telescopes of Engineering Instruments are now frequently forced renders the Telescopes objectionable, by the images being distorted and dark.

**HIGHER ALLOWABLE POWER, WITH SAME LENSES.**

**UNIFORM LENGTH OF TELESCOPE,** allowing the Telescope to be balanced in all positions, avoiding the constant annoyance in the Transit of the different lengths in reversal; and as constructed, allowing a longer

telescope for ordinary distances for same height of standard, or lower standards for same length of telescope.

**STATIONARY POSITION OF THE OBJECT GLASS,** preventing the error arising from the change of position by the irregular motion or shake in the slide.

**COMPLETE CLOSING OF THE TELESCOPE,** so that no dust or other matter can get upon the slide or inside of the tube.

**IN MINING INSTRUMENTS,** this invention has proved itself exceedingly desirable and popular. Our light mountain and mining instruments, besides totally excluding dirt, and maintaining the higher power of telescope, gives a clear reading to within four feet.

The general results of greater light, better field, somewhat increased power, increased steadiness, probability of retaining adjustment more permanently, avoidance of fretting of slide, and more complete balancing of telescope, are advantages which we confidently rely upon commending the improvements to your attention.

We have in this invention the high scientific attainments and thorough knowledge of applied mechanics of Mr. Nystrom not only added to our knowledge and experience, but likewise tested it and matured it for years, so that it may be relied upon as possessing all advantages that have been claimed.

To meet the increased cost, a charge of ten dollars additional will be made for each instrument on which the improved telescope is placed.

As one of the results of our labors to improve Engineering Instruments, we take pleasure in announcement of our improvement in

### NEEDLE READING INSTRUMENTS,

which properly can be said to be

THE ONLY IMPROVEMENT

MADE IN THE

SURVEYOR'S COMPASS

since its introduction.

Our object is to obtain a more correct reading of magnetic needle, by obviating the error of parallax.

Every Surveyor has experienced the difficulty of reading the magnetic needle accurately, from the doubt resting upon his mind as to proper position of his eye. The error arising from improper position of the eye, called *error of parallax*, can be reduced somewhat by having needle in proper balance, but without our improvement it cannot be entirely removed. The varying intensity of dip, and attraction and variation of balance of needle, render the unaided reading extremely uncertain.

The *error of parallax* is ENTIRELY REMOVED by our improvement, so that its importance, especially to Surveyor, who relies solely upon his needle, CANNOT BE OVERESTIMATED.

It will reduce many of the differences of readings which have hitherto been ascribed to the needle alone, but which undoubtedly are partly, if not wholly,



due to impossibility of accuracy, for want of some such improvement as we have made.

Through more accurate readings thus assured, the results of survey, as given by a smaller needle, may be relied upon with as much certainty as those given by a larger needle upon ordinary compasses.

Two advantages attach to this which do not generally accompany similar improvements. There are

NO ADDITIONAL PARTS,  
NO ADDITION TO WEIGHT.

Engineers and Surveyors who have used this improvement give it unqualified praise.

Notwithstanding the increased value thus afforded to Compasses, Transits, &c., we shall place the improvement upon all our new instruments, without additional charge.

To Surveyors who desire to avail themselves of our arrangement on older instruments, we make the following charges for the addition:

When repairs are made at same time,	\$2 50
" no repairs " " "	3 50

### IMPROVED VERNIERS.

(PATENTED.)

There has been granted us a Patent for Improvement in VERNIERS and GRADUATED PLATES, important, as producing

INCREASED ACCURACY IN READING GRADUATIONS,  
A REDUCED SIZE OF INSTRUMENT, and  
A REDUCTION IN WEIGHT.

The facility of vernier readings is determined by the closeness of vernier and plate. The weight of the Transit instrument is determined mainly by the size of graduated plate, and the necessary proportions of other parts thereto. The graduations of larger and smaller instruments, where difference in size is not too great, being generally performed on same Graduating Engine, there is no difference in the accuracy of the Graduations; but, as the larger the circle has the greater difference between the lines of graduation, it is the more easily read. This same difference can be produced on a smaller circle by a higher magnifying power of the reading glass, the use of which is, however, limited by two serious objections, evident from a consideration of the construction of the vernier and graduated plates as generally used. To read perfectly, two conditions have been heretofore necessary; first, that the vernier and plate should be in close contact, in order that the continuity of agreeing lines on the two should not be destroyed; second, that both plates and vernier should be on same plane, in order to avoid the error of parallax. Exactness in the first of these is impossible, as the surfaces moving upon each other, the edges on both would become rubbed, and the graduations destroyed. There must consequently be some space left, and this space is so enlarged by the magnifying power of reading glass, that the continuity of agreeing lines becomes destroyed, and the readings become uncertain. In addition to this, by the usual method of reading, this space is viewed at an

inclination, and the line of sight passing so inclined from edge of vernier to plate, and striking *below* graduations and not against them, rendering accuracy yet more difficult, and produces error of parallax.

The remedy of this first evil is sometimes the adoption of the second, of placing the inside piece, vernier or plate, below the plane of other, so that the diagonal line of sight, when it reaches the inside piece, will strike beyond this space and give a continuity of lines. This construction is generally favored by Engineers; but as heretofore constructed, the accuracy is destroyed by the error of parallax, or by the difference of readings, as the eye is moved to one side or other.

There results from these considerations the indispensable condition, that in order to read verniers perfectly correct, *the eye must be situated in the vertical plane, passing through the agreeing divisions of vernier and plate, and the centre of the instrument.* To enable this to be done with certainty, and at same time to cause the lines on vernier and plate to *appear continuous and have no space between them,* is the object of our invention. We accomplish it, by placing above the first vernier, generally on the vernier glass, a similar vernier, graduated in whole or in part, so that by bringing the eye in range of corresponding graduations on the two, the eye must necessarily be in proper position, and parallax be completely destroyed.

So complete is this simple remedy, that while, without it, there is no certainty of the eye being in proper position by several inches, with it, the motion of the eye the tenth of an inch from its place becomes apparent. It also enables more rapid readings; and in positions where Engineer is cramped for room, as in mines or steep hill sides, the ability to place eye correctly is of exceeding convenience. Coincidence of readings by different persons is secured by this vernier, a result not hitherto attainable.

As an evidence of the importance of this improvement, we are enabled to make our Transit of  $6\frac{1}{4}$  inch graduated plate read more closely than the larger instruments without it; and, while retaining the same telescope, leveling screws, &c., with same tripod, reduce the weight from 2 to  $2\frac{1}{2}$  lbs.; and, by reducing tripod proportionally, save at least 4 to 5 lbs., retaining all the merits of the present larger instruments.

### ALUMINUM.

The increased inquiries for instruments of Aluminum has induced us to make arrangements whereby we are enabled to obtain this metal in such quantities as to be prepared to fill orders. We do not, as yet, desire to endorse this metal as being suitable for the *whole* instrument, and we make wearing parts and screws of brass or hard metal, or bush the bearings. The additional cost of instrument generally ranges to fifty per cent. The saving of weight is over one-half (not including tripod).

Engineers desirous of obtaining instruments of Aluminum, by addressing us will be more fully advised of cost. Final orders must be accompanied by estimated cost of metal.

JANUARY 1, 1883.

## GRADUATING ENGINES.

With this edition, we present to the Civil Engineers of this and foreign countries, a more complete view of our line of Circular Graduating Engines. From this they may be able to judge of our capacity, both positive and comparative, to insure accuracy in the most important part of their instruments; also to judge of the labor and expense we have incurred that the work may be faithfully performed, and be such as they can implicitly rely upon.

These Engines have all been made in our establishment. They represent a cost greater, we believe, than the combined cost of all the Graduating Engines in our country; and of themselves a cost greater than the combined cost of all the instrument establishments of this city.

They are:

A Foot Engine, of 22 inches diameter, used for Protractors, Needle Rings, and such work requiring heavy graduations, but not especial accuracy.

An Automaton Engine, of 24 inches diameter, upon which is placed finer work, and which is capable, by late test, of finer graduations than any similar engine of this country.

The large Automaton Engine, 48 inches diameter, which is intended for the finest astronomical and other work, and which is unequalled and unapproached by any such engine here. *Upon this engine we now graduate our Engineers' Transits, &c.*

The vital point of any instrument is the graduation. Defects in other parts may prove an annoyance or inconvenience, and yet instrument work correctly. With defects of graduation, accuracy, if not impossible, is a mere matter of accident. Defects in ordinary parts of instrument become evident to the Engineer. In the graduations they are unknown; and frequently the only evidence of their existence is the unsatisfactory condition of the finished work, leaving the Engineer in doubt whether the unsatisfactory results, condemning his work, arises from his own carelessness or the imperfections of his instrument. It is not necessary errors should be found in all parts; the mere fact that an error may exist anywhere is sufficient to throw doubt upon the work. In fact, the want of *positive knowledge* that *no error CAN exist*, is sufficient to make every conscientious Engineer hesitate in the choice of an angular instrument.

While imperfect graduations most frequently arise from imperfect engines, a common cause of error is carelessness, or inexperience in manipulation. The

delicacy required in graduations of Transits, &c., is such that reliance cannot be placed upon personal operation. The heat of the body in contact with the engine, the uneven strain placed upon the parts by the hand, the uneven velocity, and especially the many evils resulting from the long continued strain upon the attention of the individual, make the AUTOMATON movement necessary for any approach to perfection.

Errors of graduation frequently run in periods, so that one or two repetitions, should they fall within these periods, give the same, though false results.

It sometimes happens that the regular errors of engine are partially balanced by accidental errors in process of graduation, which is one cause of different amounts of error to be found in the different instruments of some makers; and which, perhaps, partly accounts for certificates of performances of some instruments, ascribing to them a certain maximum error, when it is well known the error of engine upon which they were graduated is four or five times that amount. But as these accidental errors the next time may increase instead of diminishing the regular errors, it is manifestly unsafe to rely upon such certificates for what the next instrument may be.

In surveys requiring large triangulations, the accuracy of results being in proportion to the accuracy of graduations, we feel justified in considering it a matter of prudence on part of Engineers in charge, to avail themselves of the facilities which our labor and investments afford them.

With our perfect provisions for securing accuracy in graduations, there remains but one obstacle, the error of Parallax,—completely removed by our Patent Vernier,—so that the Engineer using one of our late instruments, can congratulate himself upon having one, for working purposes,

SUPERIOR TO ANY NOW MADE.

Engineers are reminded of the great superiority given our TRANSITS, in addition to the merits of their graduation, by our

PATENT VERNIERS,

PATENT TRIPOD,

IMPROVED EYE PIECE,

IMPROVED SLIDE PROTECTOR,

IMPROVED TANGENT,

IMPROVED TELESCOPE,

GRADIENTER.

No Transit now made approaches these instruments in perfection, accuracy or convenience. They are the ONLY instruments to which any bona fide improvements have been added



## TELESCOPES.

---

Telescopes placed upon our instruments within the past few years have, as we remarked, a higher power than was formerly placed upon the generality of these instruments.

The general demand is for a high power; and those unacquainted with subject consider the higher power the better telescope. The *power* of a telescope depends upon proportion of focal lengths of object glass and eye piece, and while in theory *any* power may be given to any telescope, in practice the extent is limited by other *points*, such as effects of aberration, loss of light, and size of field of view. With the same object glass *every* increase of power is followed by a decreased illumination, or a decrease of light and a smaller field. These results follow in obedience to mathematical laws, and cannot be obviated. Science has given certain proportions between power and length of telescopes, and the best opticians of Europe, with their extended experience, invariably follow these proportions.

The practice in this country of late has been to force the power beyond these bounds; the result is, that while under very favorable circumstances the centre of field of view will give a somewhat better definition, it will only do so under favorable circumstances, such as clear atmosphere and strong illumination of the object, and that either the field must be much reduced or objects out of immediate centre will not be in focus. In cloudy weather, in lesser light of morning and evening, in the tremulous condition of atmosphere, arising from evaporation from surface of ground, especially cultivated, these high powers all suffer.

There are purposes, where great definition is so much an object as to supersede all other telescopic requirements, in which these high powers are advisable; but the Engineer should understand that in using them what he loses on the other points, and especially remember the exact focusing required of them, otherwise parallax produces a sensible error. For rapid working the exact focusing of high powers is a drawback,—a change in telescope being required for almost every small change of distance. Comparison of two telescopes differing widely in power will illustrate this. In the lower powers, in ranging a line, distances between 300 and 400 require little if any change, and same of say 500 and 700, or 800 and 1200; but in higher powers every change of a few feet, until practically parallel rays are reached, requires separate focusing, and if not properly focused are liable to be less distinct than the lower powers.

The loss of light, even in the best high powers, is what gives an impression of glass being "less distinct" on its first use, for though smaller objects are better defined by it, the impression on its first use is one of cloudiness.

Fortunately the particular use of engineering instruments requiring definition on but one point at a time, allow us to make other conditions of optically good glass subordinate to this one of power to a great extent.

INVERTING glasses are not more powerful, except that from small space occupied by the eye piece, they allow for same length of telescope a greater focal length of object glass and thus increase the power.

They however have a much greater amount of light, or greater illumination and a much larger field. The prejudices of American Engineers are against them, but in Europe, &c., their merits are almost universally acknowledged, and they are almost the only ones used. For mining and astronomical purposes they are preferable.

We have remarked on this subject because of the gradually increasing interest of Engineers, and that they may form an idea of the principles governing instrument makers, desirous of giving the best general, but not sensational, properties to the telescope.

As a rule we give such power as possible without positive injury. Our Transit telescopes of 10 inches in length have power of 20 to 22; of 11½ inches in length a power of 23 to 25. The Levels a power ranging from 22 in our 17 inch to 50 in our 22 inch.

Changes in these powers can be made; but we advise Engineers not to make them without consideration.

---

## STADIA.

With the higher powers given our telescope of late years, the introduction of Stadia wires has been more frequent and accuracy of measurements made by them proportionally increased.

Within certain bounds, and with use of self-reading rod, they can be made fully as accurate as the ordinary rough chaining with the old heavy chain. When great distances are used, when distance is beyond perfectly distinct vision of telescope, the advantage is on side of chaining; for while, other circumstances being the same, the percentage of error in chaining, which is analogous to determination of angle in stadia, remains constant, the distinctness, or the facility of sighting to any determined limit, say the hundredth of a foot, decreases rapidly with increase of distance. Experiments and actual work confirm these conclusions.

Over rough ground the advantage is in favor of stadia, while over smooth ground, especially with the lighter chains and the chain tapes used, it must be careless chaining that does not give better results.

The angle of inclination forms a difficulty in using stadia wires, requiring a measurement of this angle and calculation for purpose of reduction, or some means such as our right angled sight to bring the rod perpendicular to line of sight. The right angled sight is carried by the rodman; one arm is held firmly against the rod while the eye ranges the other arm to the instrument; so the measurements are made on the rod as on a right angled base.

Exact measurements of base being required, at great distances the two targets must be used and set, causing the work to be comparatively slower.

Want of flatness in field of view is a great disadvantage in the stadia, but one that cannot be avoided, except in perfection of telescope. The observer should be careful to obtain exact focus, as out of focus the image of rod occupies a larger space, while stadia wires cover always the same.

Measurements by stadia do not start from centre of instrument, but from a distance beyond object glass equal to the focus of object glass. This distance may be found by measuring from face of object glass to the cross-web, which is generally one-quarter of an inch nearer the eye than middle of cross-web screws. The correction thus found is a constant, to be always added to distance of observation.

There are two methods of attaching the stadia wires—the fixed and adjustable.

The fixed are fastened on web piece along with the regular wires; they are upon same plane, and in adjustment of wires there is no motion of one upon other to drag either out of place. By an improved arrangement in connection with our straight line engine we are enabled to place the cross-webs in proper position, with as much, if not greater, exactness than they can be adjusted, and the distance between middle wire and the two outside wires always remains constant, no matter how much the middle one may be changed by losing its adjustment or by process of adjusting.

In the adjustable attachment the distances between webs are much more liable to change, and even in constructions, intended to avoid the difficulty, are necessarily affected, not only by their own adjustment, but as well by that of regular wires, and this not only in width of outside webs, but especially in the distances of these from middle ones.

There are few occasions in which use of stadia can supersede the use of the chain; but there are many in which they become extremely useful, and considering the accuracy of which they are capable, and that they in no wise interfere with other uses of instrument, they form a desirable addition. For moderate distances, across ravines, streams, swamps, for measurements in topographical surveys, and for checks on the chain, they are of great value. For topography, especially, they are excelled by no arrangement but our Gradiometer.

## LEVELS.

---

Our Levels are divided into two classes. In No. 1 the levelling screws are attached permanently to the centre, and the instrument detaches only from tripod; the object is to afford a somewhat better protection to the centres, which pass down through the plate carrying the screws.

In No. 2 the telescope and bar detaches from levelling screws, which likewise detach from tripod. The object is to allow the most important parts, telescope and level, to be speedily detached and carried separate.

The telescopes, level, bar, screws, &c., are the same in both instruments.

The LEVEL TUBES used are ground uniformly the whole extent of the circumference, as giving a more perfect form and more regular motion than where ground merely upon the upper surface. This form, though more expensive, we have found the only one to be relied upon.

The curve of surface is such as to give an angle two minutes for each inch of motion of bubble, or for each division on scale an angle of twelve seconds; and as difference in reading of two ends of bubble indicate double actual motion of bubble, it follows that each difference of one division between two ends of bubble indicates an angle of six seconds.

This is the usual rate. For lighter levels it is made less, and for special circumstances increased, frequently doubled.

As a general rule, the more sensitive the bubble the more perfect the work, but in an exceedingly sensitive level will not remain stationary and is difficult and annoying to work. On the other hand a dull level, while it gives the appearance of steadiness to instrument, and an impression that it "keeps" its adjustment, is incapable of accurate results. The instrument which retains adjustment of level should be examined by testing the value of motion of bubble, to ascertain if it is in consequence of a good or a bad quality.

The 22 inch Telescope Level is intended to meet the wants for an extra instrument, as for city and hydraulic work. The telescope is larger, the centres are longer, the tripod wider, and the levelling screws are passed through nuts that can be tightened, so as to insure perfect steadiness on this part. The level is extremely sensitive, and the whole instrument arranged as to give the most accurate results possible.

All these instruments are furnished, unless otherwise ordered, with our improved Eye Piece, Slide Protector and Fastener. This last attachment merits especial attention, as contributing not only to speed and convenience, but also in an exceeding degree to accuracy.

The Tripods have cast steel shoes, which should be kept moderately sharp. The legs are of Spanish cedar, as giving the firmest tripod with the lightest weight, and the heads or bearing surfaces are faced with hard wood.

Interchanging Tripods of Transits and Levels is not recommended; but our's are so made that Tripod of No. 1 Level can be used with our long centered Transits, and Tripod of No. 2 Level with our flat centered Transits.



# IMPROVED LEVEL.

*Patented by L. B. DENISON, Feb'y 3, 1886.*

The aim of this Level is to furnish an instrument which is capable of

INCREASED STEADINESS,

USE OF MORE SENSITIVE SPIRIT LEVEL,

SMOOTHER MOVEMENT OF LEVELLING APPARATUS.

The object is accomplished :

- 1st. By use of longer radius upon which the levelling motion is made.
- 2d. By use of independent centres for the motions, at right angles to each other.
- 3d. By having these centres unconnected with the attachment of the levelling screws, so that the action of the screws neither tightens nor loosens the centres upon which the levelling takes place.

This action of the screws in one direction being effected upon their own centre, without any movement or direct action upon the centre on which other screws move, leave the whole instrument free from strain.

By the construction, the centre upon which the instrument revolves can be made longer, while the whole instrument is kept lower in the tripod. This length of centres is another cause for increased steadiness, to which the low position on tripod contributes, and is an end sought in all instruments.

For City and Hydraulic Engineering, for the finer kinds of Railway work, such as depots, buildings and track levels, this instrument will be found more satisfactory in its workings and results.

For details of the instrument, telescope, and common to this and other levels, see our Manual and Catalogue.

## PRICES:

All our improvements on Telescopes, etc.

For 17 in. Telescope, power 22, . . . . .	\$165 00
" 18 " " " 40, . . . . .	175 00
" 20 " " " 45, . . . . .	185 00
" 22 " " " 50, . . . . .	200 00

The Improved Tripod can be placed upon old Levelling instruments, the cost varying with construction of the instrument.

DENISON'S IMPROVED LEVEL  
YOUNG & SONS, PHILADELPHIA.

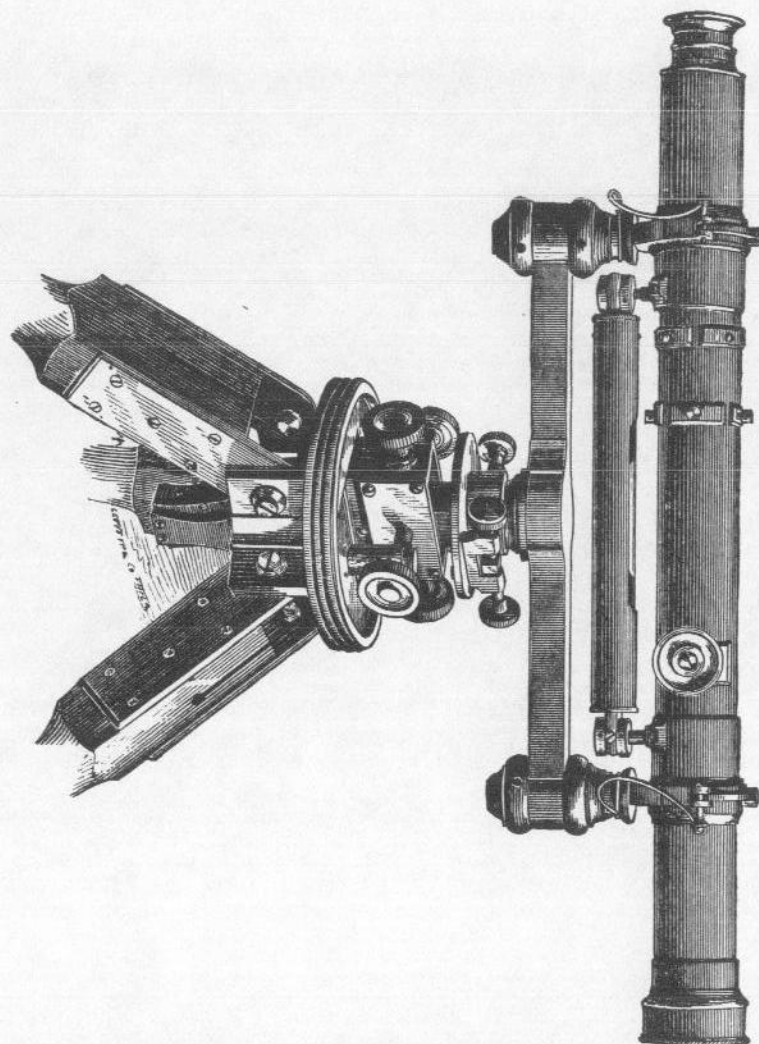

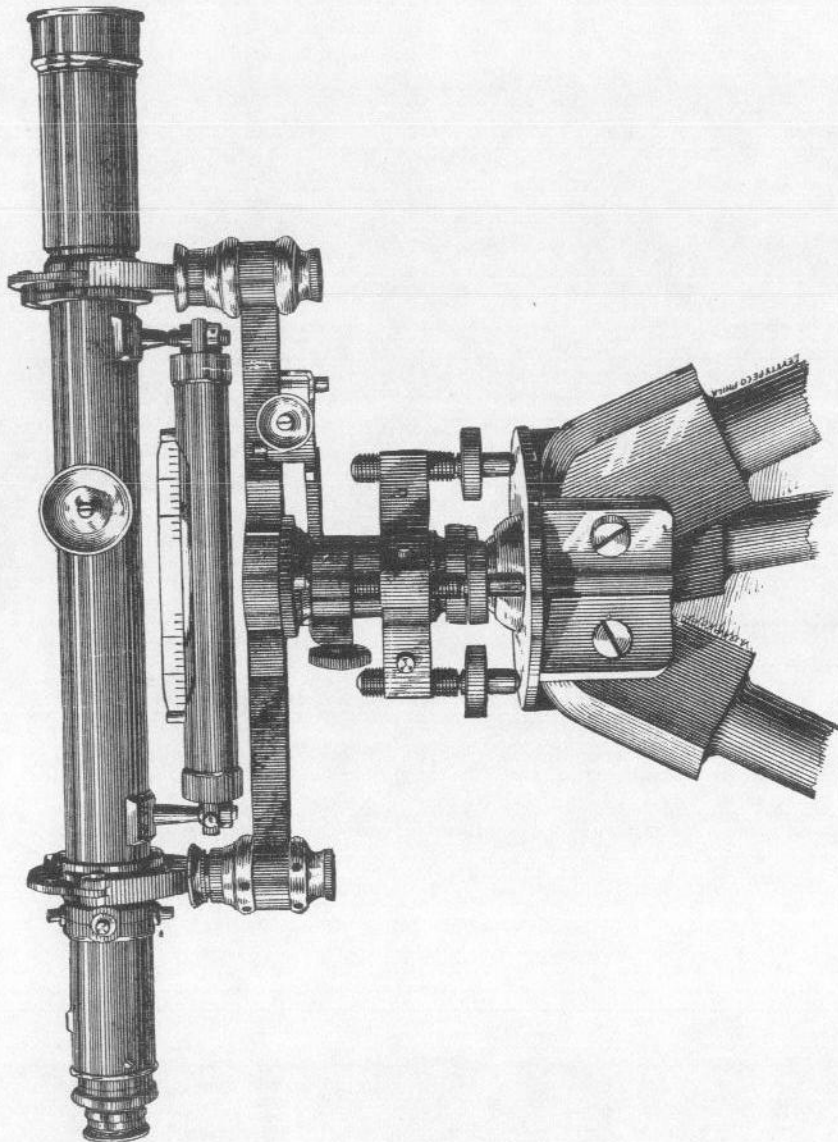

18 Inch Level.—No. 1.

### LEVELS, No. 1 and 2.

No. 1.—The centres are connected permanently with the level screws, and instrument detaches only from tripod.

No. 2 detaches both from tripod and from level screws.

Telescope, 17 inch, power 22, weight 17 lbs., . . . . .	\$140 00
“ 18 “ “ 40, “ 17½ lbs., . . . . .	150 00
“ 20 “ “ 45, “ 18½ lbs., . . . . .	160 00
“ 22 “ “ 50, “ 22 lbs., . . . . .	185 00
Stadia Hairs fixed, extra, . . . . .	8 00
“ “ adjustable, extra, . . . . .	8 00

The screws pack in box with instruments.

The instruments are furnished with

YOUNG'S IMPROVED EYE PIECE,

“ “ SLIDE PROTECTOR,

“ “ FASTENER, to keep vertical and horizontal cross-  
webs in position.

Without these improvements, price \$10 less.

The instruments are furnished with shade, cap, screw-driver and levers.

Young's Self Reading Level Rod, (see description), . . \$18.00.

### No. 2½, LIGHT LEVEL.

Telescope, 15 inch, power 16, weight 11 lbs., . . . . . \$115.00

This level is capable of all adjustments of larger instruments. Has no clamp or tangent.

### THREE SCREW LEVELLING TRIPOD.

Levels Nos. 1 and 2 are made, if desired, with three screw open tripod. The construction has not the firmness for transportation possessed by the four screw tripod; but is more steady in use, can be used with more sensitive levels, and has reputation of giving more accurate results.



## TRANSITS.

From the various instruments made in ordinary course of our business, we have selected the following list as being the most usual, and one that will meet the wants of almost the entire range of instrumental work.

Larger instruments, and of many different patterns to suit especial work, have been sent from our establishment, but their enumeration would be too long for our purposes.

While, for railway work, our No. 6, smaller size, and for town work, &c., No. 6, larger size, will meet general requirements, we are frequently called for instruments in which accuracy is not so much desired as ability to stand rough usage, and yet more frequently for instruments capable of greatest exactness.

In construction the principal division of Transits is into long and flat centres. The flat centre is best adapted to withstand rough work, and is in many respects the most portable. The greater friction of plates upon each other, and the consequent wear upon centres, makes it less reliable for angular measurements, and where level is attached to transit telescope, the instrument is not so steady. The peculiar construction of centre, being a flat cone, prevents this part from injury by a fall, and makes the correction of shake in centre a comparatively easy matter to the Engineer himself.

In the long centre instrument there are two cones, one inside the other. The weight of instrument is received on a shoulder of these centres, while the long conical fittings relieve this weight to a slight degree, and when properly fitted prevent all shaking. Any injury to the centre, however slight, though is exceedingly serious in its results, generally renders instrument useless at once and cannot be remedied outside of instrument makers. Nevertheless, the superiority of this form for angular measurements causes its almost universal adoption.

TELESCOPES.—The telescopes on our Transits are made to reverse either end, except on special occasions. The power is graduated to the work to be performed, ranging from 14 on our smaller ones to 30 on the larger.

The main principles governing application of telescopes will be found under head "Telescopes."

The *Eye Piece*, upon which much of the perfection of telescope depends, receives especial attention. Generally, and unless otherwise ordered, the erect eye piece is used. For Mining purposes, Tunnel instrument, and for highest class of instruments the inverting is substituted.

*Diagonal Eye Pieces* for observations of stars for meridian, as well as for observations at larger vertical angle than with ordinary eye piece, are generally made by us with a simple prism attachment, as being the most convenient and expeditious.

REFLECTOR PLATES for illumination of cross-webs, for observation on stars, for work in mines, where light received is not sufficient of itself, are attached by us to the object glass, by means of a frame work holding a reflector plate faced with solid silver, and placed at an angle with axis of instrument. This plate is perforated at centre to allow observation of object, while the light of a lamp held backward and sideways is reflected upon cross-web.

The *Compass Needle* is made of careful forgings, greatest measure vertical, to insure steadiness and avoid that unsteady motion mistaken sometimes for sensitiveness, which is of no service to needle, but an annoyance to the surveyor. It has also a large cross section to secure magnetic power, a matter we regard of consequence, the flat thin or square needle used on second class instrument being merely a device to save cost of construction.

• **COMPASS FACE** in all but smaller instruments are bronzed, to prevent reflection of sun into the eyes. A small silvered ring, immediately under end of needle, secures all the advantage of the full silvered face.

VERNIERS of our instruments are so placed that they may be easily read while in position to observe through telescope. The advantage of being able to read, or set off an angle, when in confined positions, or upon ground where any motion of Engineer would disturb the instrument, is so great that, once accustomed to them, Engineers always give them the decided preference. The light upon the verniers is more in this position, not being so much interfered with by the standards. Verniers are in all cases double, reading right and left.

DECIMAL VERNIERS.—Graduations into decimal parts of a degree has been placed upon our instruments for many years, before being adopted on any others. Its adoption is due to Samuel W. Miffin, C. E., and its use is almost universal amongst the Pennsylvania Rail Road Engineers, and those who have graduated under their instruction. The great advantage is convenience in deflecting for curves, the tangential deflection for a 2° curve being the hundredth of a degree for each foot of distance, and in proportion curves of other radii.

The general way of placing on our Transits is to make one vernier decimal and one into minutes.

The level to telescope, with tangent or opposing screws, the vertical arc, and the gradienter, are considered as attachments to the plain Transit. They can be placed upon any of the instruments, and do not in any manner modify the main parts.

The LEVEL, as placed upon telescopes of our Transits, is as sensitive as those usually placed upon the level instruments of other makers. The divisions are generally placed upon the glass itself in preference to the brass scale.

The opposing screws for holding this level hold it firmest in windy weather, the tangent screw or spring gives the smoothest most regular motion.

The VERTICAL ARC with LOOSE VERNIER, as introduced by us 24 years ago, is almost entirely used by us. The full vertical circle is, from its peculiarly exposed position, constantly liable to injury, and when but even slightly injured, is not only useless itself but interferes with other use of instrument, by throwing line of collimation out on reversals. The loose vertical arc measures 60° either way, and by repeating may be made to measure 180°. No injury to it affects the other part of instrument. Its introduction was a decided improvement on Transit.

Tangents are generally made with a double spring, to prevent lost motion in screw. As a decided improvement we cover them to keep away dirt, reducing the wear and giving a much smoother motion, without necessity of so tightly clamping or springing nuts to force dirt out as it enters these nuts.

They are placed under the instrument to protect them from injury, while the point of attachment is so far from the clamp where it touches plate, that the smallest motion does not deprive it of all resemblance to a tangent.

The **DUST COVER** is broad, running a long distance under plate, so as to effectually exclude dust from between the edges of graduated plate and vernier.

**TRIPODS.**—The legs are made of best seasoned, straight grained wood. The shoes are of cast steel; points of sufficient thickness to allow sharpening often,—a matter of consequence, as dull shoes are a great drawback to steadiness of instrument. The bearings of legs in tripod head are now generally faced by us with hard wood, by which the benefits of a much heavier leg are secured without its weight.

The *weight* of an instrument is frequently reduced by reducing the weight of tripod at a sacrifice of steadiness. A tripod too light destroys all the merits of an instrument.

All Transits are furnished with plummets, reading glasses, adjusting pins, screw-drivers and shades, and levelling screws in all cases pack in box.

All telescopes balanced generally made to revolve at both ends.

**No. 3.**

Weight of instrument, plain, 6½ inches graduation, . . . . .	19 lbs.
“ “ “ 6¾ “ “ “ . . . . .	21 lbs.
Power of telescope, 20 to 24.	

Flat centre.

Outside vernier to plates: verniers reading either minutes, or decimals and minutes.

Vertical adjustment to telescope.

Needle, 4½ inches.

Graduations, 6¼ inches.

Tangent to plates.

Improved attachment to tripod.

Screws pack in box, . . . . . \$170 00

With needle 5 inches.

With graduations 6¾ inches, . . . . . \$180 00

These instruments are furnished with

YOUNG'S IMPROVED EYE PIECE,

“ “ SLIDE PROTECTOR,

“ “ TANGENT,

“ PATENT SHIFTING TRIPOD,

“ IMPROVEMENT FOR OBVIATING ERROR OF PARALLAX.

Without these improvements \$10 less.

Extra:

Graduations, reading 20 seconds or 30 seconds, . . . . .	\$10 00
Vertical Arc, . . . . .	15 00
Level to Telescope, with opposing or tangent screw, . . . . .	25 00
“ “ “ “ “ “ and vertical arc, . . . . .	40 00
“ “ “ “ “ “ circle, . . . . .	43 00
Gradienter, including Level to Telescope, . . . . .	40 00
“ “ “ “ “ and vertical arc, . . . . .	55 00
“ “ “ “ “ circle, . . . . .	58 00
Stadia wires, fixed, . . . . .	3 00
“ “ adjustable, . . . . .	8 00
Diagonal Eye Piece Attachment, . . . . .	8 00

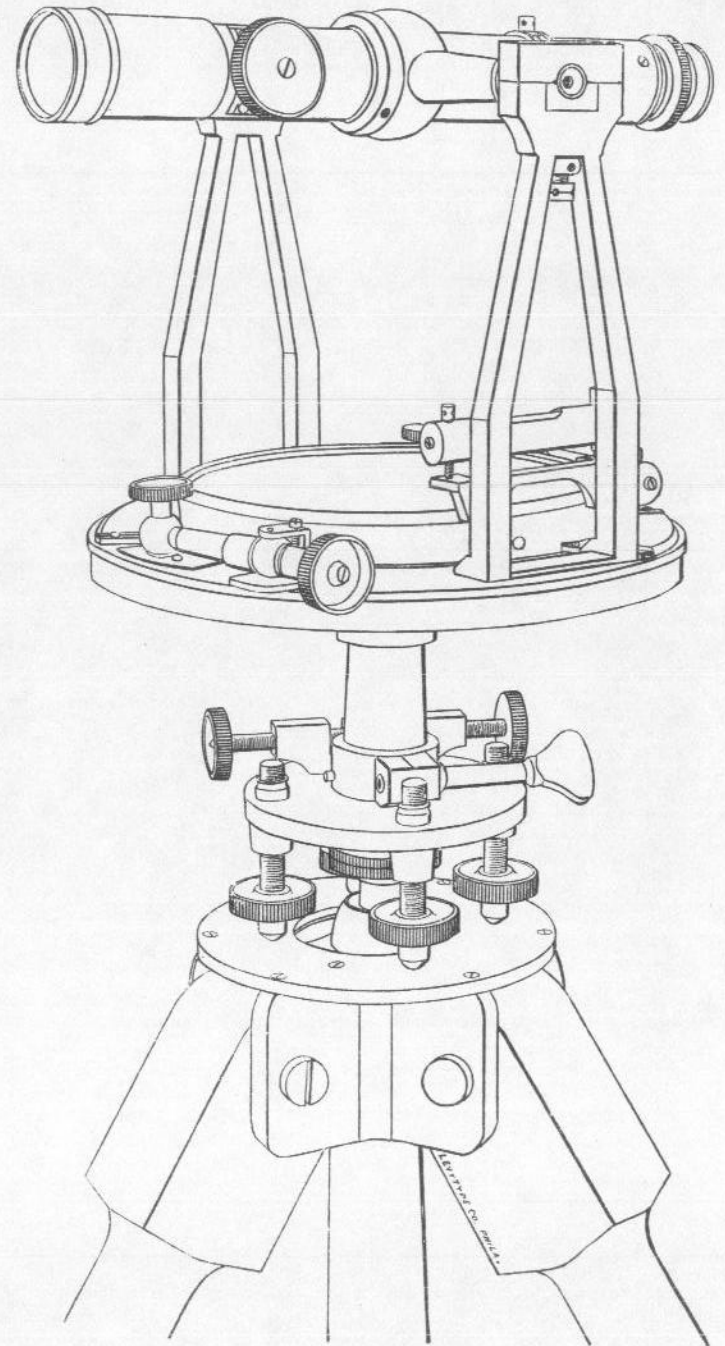

No. 3.—Plain.



## No. 6.

*This we consider the Transit best adapted for general purposes and for Railway work. The 4½ inches Needle and 6½ inches Graduation is our standard for Railway work, and the instrument we send when one is ordered without limitation as to size or quality.*

Weight of instrument, plain, 6½ inches graduation, . . . . .	19½ lbs.
“ “ “ 6½ “ “ . . . . .	21½ lbs.

Power of telescope, 20 to 24.

Long centre.

Two outside verniers, reading minutes, or one minutes and one decimals.

Needle, 4½ inches.

Graduations, 6½ inches.

Tangent to plates.

Vertical adjustment to telescope.

Improved attachment to tripod.

Screws pack in boxes, . . . . . \$200 00

With needle 5 inches.

With graduations 6½ inches, . . . . . \$210 00

These instruments are furnished with

YOUNG'S IMPROVED EYE PIECE,

“ “ SLIDE PROTECTOR.

“ “ TANGENT,

“ PATENT SHIFTING TRIPOD.

“ IMPROVEMENT FOR OBVIATING ERROR OF PARALLAX.

Without these improvements \$10 less.

Extra:

Graduations, reading 20 seconds or 30 seconds, . . . . .	\$10 00
Vertical Arc, . . . . .	15 00
Level to Telescope, with opposing or tangent screw, . . . . .	25 00
“ “ “ “ “ “ and vertical arc, . . . . .	40 00
“ “ “ “ “ “ circle, . . . . .	43 00
Gradienter, including Level to Telescope, . . . . .	40 00
“ “ “ “ and vertical arc, . . . . .	55 00
“ “ “ “ “ “ circle, . . . . .	58 00
Stadia wires, fixed, . . . . .	3 00
“ “ adjustable, . . . . .	8 00
Diagonal Eye Piece Attachment, . . . . .	8 00
Variation Plate, . . . . .	10 00

### THREE SCREW LEVELLING TRIPOD.

*Transits Nos. 6, 7 and 13 are made with the three screw level head and open tripod, same as in Repeating Circle. While the tripod is not as convenient for transportation, the instrument is adapted to secure greater accuracy of results, by relieving centres from strain, and by securing more perfect horizontal adjustment, and is steadier when in use.*

*In surveys, where accurate angles and long lines are called for, this construction is desirable. The objections made are generally overcome with slight use.*

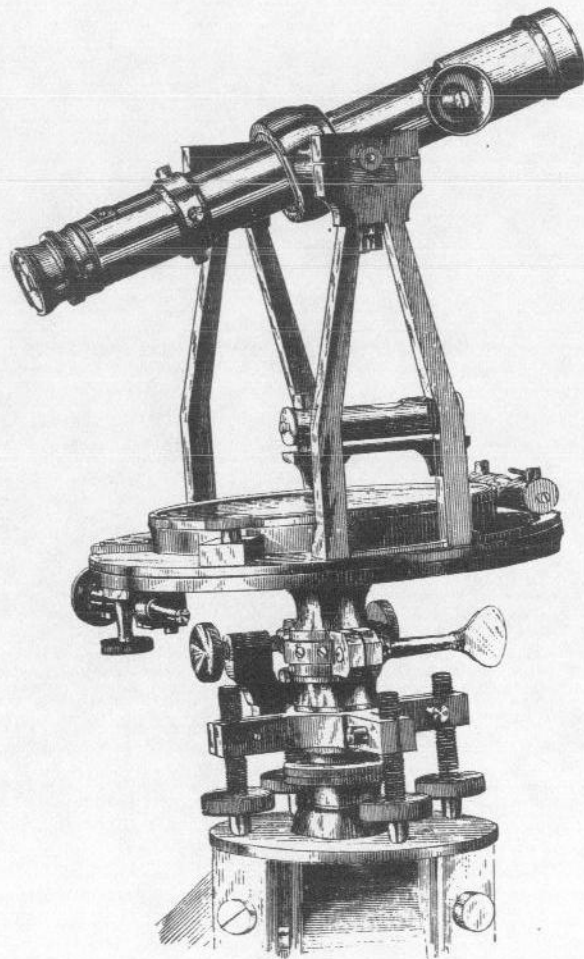

No. 6. PLAIN.

## No. 7.

## For City and Bridge Engineering, &amp;c.

In this instrument we have endeavored to combine every excellence requisite for perfect work possible in an instrument of its size. The main parts are of same size as No. 6, the principal difference being in graduations on solid silver, in the telescope being inverted when desired, and in levelling screws passing through nuts (as in our 22 inch level), which are capable of being clamped to remove all shake in screw, increasing steadiness of instrument in a remarkable degree.

While making the smaller size, we recommend the larger, graduated to 20 seconds.

Weight of instrument, plain, 6 $\frac{1}{2}$ inches graduation, . . . . .	20 $\frac{1}{2}$ lbs.
“ “ “ 6 $\frac{3}{4}$ “ “ . . . . .	23 lbs.
Power of telescope, 22 to 26.	

Long centre.

Two outside verniers, reading minutes or decimals, or one minutes and one decimals.

Graduations on solid silver, 6 $\frac{1}{2}$  inches.

Needle, 4 $\frac{1}{2}$  inches.

Tangent to plates.

Vertical adjustment to telescope.

Telescope, large, either inverting or erect.

Improved attachment to tripod.

Screws pack in box, . . . . . \$225 00

With graduations 6 $\frac{3}{4}$  inches.

With needle 5 inches, . . . . . \$235 00

These instruments are furnished with

YOUNG'S IMPROVED EYE PIECE,	
“ “ SLIDE PROTECTOR,	
“ “ TANGENT,	
“ “ SHIPPING TRIPOD,	
“ IMPROVEMENT FOR OBTIATING ERROR OF PARALLAX.	

Extra:

Graduations, reading 20 seconds or 30 seconds, . . . . .	\$10 00
Vertical Arc, . . . . .	15 00
Level to Telescope, with opposing or tangent screw, . . . . .	25 00
“ “ “ “ “ “ and vertical arc, . . . . .	40 00
“ “ “ “ “ “ “ “ circle, . . . . .	43 00
“ “ “ “ “ “ “ “ “ “ circle, . . . . .	40 00
Gradienter, including Level to Telescope, . . . . .	40 00
“ “ “ “ “ “ and vertical arc, . . . . .	55 00
“ “ “ “ “ “ “ “ circle, . . . . .	58 00
Stadia wires, fixed, . . . . .	3 00
“ “ adjustable, . . . . .	8 00
Diagonal Eye Piece Attachment, . . . . .	8 00

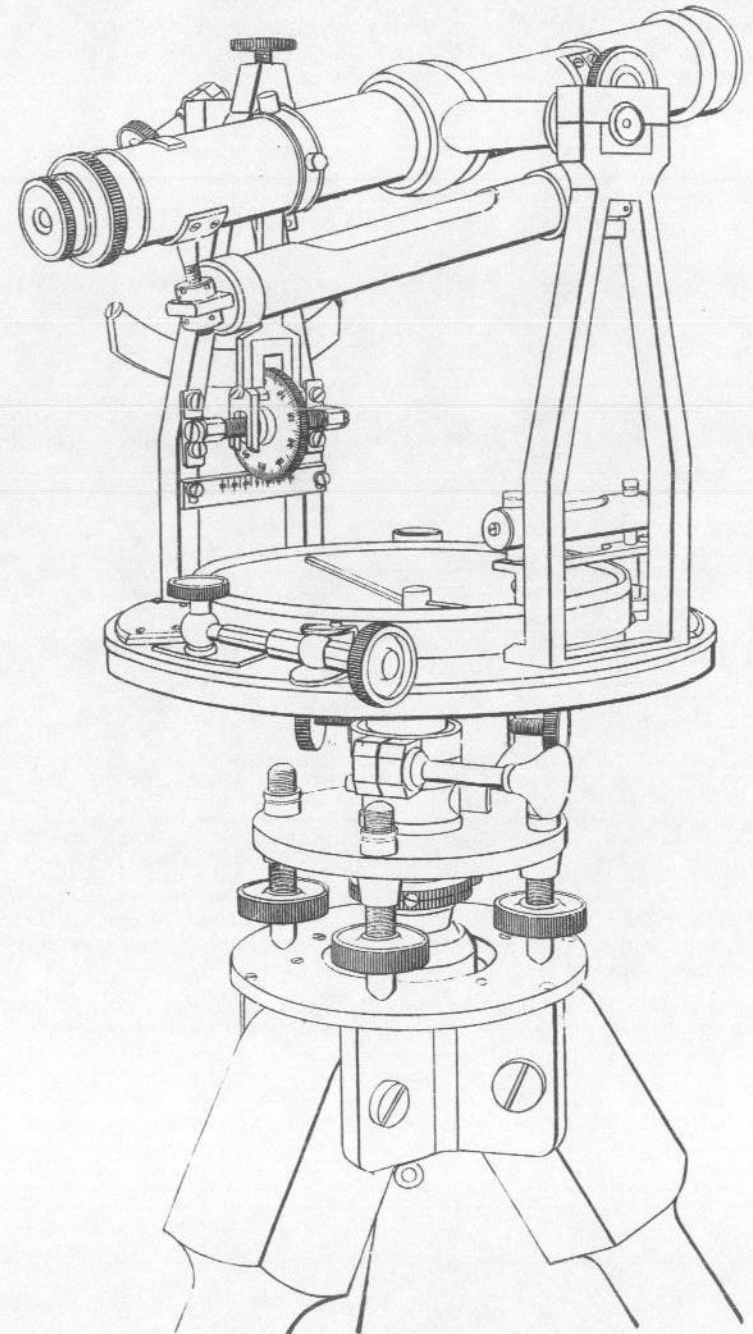

NO. 7.—WITH GRADIENTER,  
LEVEL TO TELESCOPE,  
AND VERTICAL ARC.



## No. 10.

## 10 lb. or MOUNTAIN TRANSIT.

*This instrument is same as Mining Transit No. 8. It is designed for such Engineering as needs a light, portable instrument. In workmanship, graduations and proportionate strength, it is as reliable as larger instruments, principal difference being in weight. It has simply, in construction, the disadvantage of smaller circle and smaller needle.*

It is equal to performance of all the ordinary duties of Railway work.

The centres are longer than the centres of the usual larger instruments of the country, being over three inches. The telescope has object glass of one inch opening, and seven inches focus, with power either of inverting or erect eye piece of from 9 to 14. As usually constructed for mining purposes, it has the inverting telescope, affording extra light, larger field and shorter telescope, for same focal length of object glass.

The verniers are wide, extending to edge of plate, to allow extra amount of light. They have advantage of being so placed that the Engineer can read the plate without changing his position, risking the disturbance of instrument.

Long centre. .

Two outside verniers, reading minutes or decimals.

Needle,  $3\frac{1}{2}$  inches.

Graduations,  $4\frac{3}{4}$  inches.

Tangent to plates.

Vertical adjustment to telescope.

Eye piece, either inverting or erect.

Shifting tripod.

Screws pack in box.

Improvement for Obviating Error of Parallax. . . . . \$170 00

Extra:

Graduations, reading 20 seconds or 30 seconds, . . . . . \$10 00

Vertical Arc, . . . . . 15 00

Level to Telescope, with opposing or tangent screw, . . . . . 25 00

" " " " " " and vertical arc, . . . . . 40 00

" " " " " " " " circle, . . . . . 48 00

Gradienter, including Level to Telescope, . . . . . 40 00

" " " " " " and vertical arc, . . . . . 55 00

" " " " " " " " circle, . . . . . 58 00

Stadia wires, fixed, . . . . . 3 00

" " adjustable, . . . . . 8 00

Diagonal Eye Piece Attachment, . . . . . 8 00

### FOLDING TELESCOPIC SIGHTS AND RIGHT-ANGLED SIGHTS

Are also placed upon Nos. 3, 4, 6, 7 and 10.

Extra, each, . . . . . \$8 00

*The present construction of our Transit Standards renders the Right Angle Sights unnecessary.*

No. 12.  
**REPEATING CIRCLE.**  
 COAST SURVEY PATTERN.

Repeating circles differ from Transits mainly in the telescopes not revolving on axis. The name is generally given to a class of instruments intended for angular measurements of great accuracy. The uprights are made as low as possible for the work to be performed.

This instrument is made from pattern designed by us for several instruments made for United States Coast Survey. There are three levelling screws. The tripod has a wide base, and legs are made of open frame pattern, to secure steadiness with lightness.

When needle is desired it is placed on by means of an oblong box, which is detachable from instrument when not in use. It has a movement of 20 degrees of arc on each side of meridian.

Where vertical circle is used it is made to use on either side, as reversed on axle.

Long centre.

Spring tangent to lower plate.

Graduations, 8 inches on solid silver.

Two verniers reading 10 seconds.

Reading glasses to verniers.

Telescope, 17 inches, axis reverses in Y bearings.

Clamp and spring tangent to axis of telescope.

Striding level, ground extra sensitive.

Balance weight on end of telescope.

Inverting eye piece, . . . . . \$330 00

These instruments are furnished with

YOUNG'S IMPROVED EYE PIECE,

" " SLIDE PROTECTOR.

" IMPROVEMENT FOR OBVIATING ERROR OF PARALLAX.

Extra:

Vertical circle, 6 inches, graduated to read 30 seconds, with level attached, . . . . .	\$60 00
Compass box, . . . . .	18 00
Inverting eye pieces extra, each, . . . . .	10 00
Stadia wires, fixed, . . . . .	3 00
" " adjustable, . . . . .	8 00
Four verniers to horizontal plate, . . . . .	20 00

*Repeating Circles of larger size and finer graduations, as desired.*

No. 13.  
**CITY AND TUNNEL TRANSIT.**

*Adapted especially for straight lines.*

The axis of telescope is set upon Y bearings, and the telescope by a sliding weight, of our adaption, is balanced that it may move easily and not risk disturbance in revolving it. The axis bearings are cylindrical, that the telescope may be reversed on these bearings as well as revolved on them. This affords opportunity for testing adjustment of collimation speedily without change of instrument, or if not in adjustment, of marking two points the mean of which is correct.

A striding level resting upon the journals tests motion of telescope in a vertical plane. As generally made for tunnel work, the eye piece is inverting to obtain light.

The instrument is frequently made with standards low, to secure greater steadiness. It then loses its character of transit, and the telescope cannot be revolved, but the reversal on axis bearings allows adjustments to be readily made and back sights taken.

We frequently make them without the circular needle box, the advantage gained is reduced height of standards. An oblong needle box, similar to No. 12, is then attached.

These instruments are sometimes made with hollow telescope axis and reflector illuminating web, on inside of telescope tube.

Y bearings.

Hollow pillar supports.

Long centre.

Two outside verniers, reading minutes or decimals, or one minutes and one decimals.

Graduations, 6 $\frac{1}{2}$  inches.

Needle, 5 inches.

Tangent to plates.

Vertical adjustment to telescope.

Striding level to axis of telescope, . . . . . \$250 00

These instruments are furnished with

YOUNG'S IMPROVED EYE PIECE,

" " SLIDE PROTECTOR,

" " TANGENT.

" IMPROVEMENT FOR OBVIATING ERROR OF PARALLAX.

Extra:

Graduations to 20 or 30 seconds, . . . . .	\$10 00
Graduations on solid silver, . . . . .	25 00
Diagonal eye piece attachment, . . . . .	8 00
Stadia wires, fixed, . . . . .	3 00
" " adjustable, . . . . .	8 00
Oblong needle box (detachable) in lieu of circular ring, . . . . .	16 00



## MINING TRANSITS.

Mining Transits differ from ordinary ones principally in being of smaller size for greater portability, in having telescope admitting more light, and having a greater range of vertical angle.

The graduations of plates are frequently stamped with cardinal points of compass, to keep correspondence of angles when checking with needle.

We would advise to have the needle ring and plates both numbered from 0° to 360°, all danger from error in reading cardinal points being thus avoided.

### No. 14; or MINING TRANSIT No. 1.

*The general dimensions are same as No. 6 or 7, with level to telescope and vertical arc.*

#### MINING ATTACHMENTS:

Side telescope, revolving full vertical circle, independent of centre telescope.

Diagonal eye piece to side telescope.

Full vertical circle, graduations on silver.

Counterbalance.

The vertical circle, with side telescope and counterbalance, detachable, \$300 00

Same instrument, with side telescope revolving along with, not independent of, centre telescope, . . . . . 280 00

These instruments are furnished with

Young's IMPROVED EYE PIECE,	
" " SLIDE PROTECTOR,	
" " TANGENT,	
" PATENT SHIFTING TRIPOD.	
" IMPROVEMENT FOR OBVIATING ERROR OF PARALLAX.	

Extra:	
Graduations of plate, solid silver, . . . . .	\$25 00
Clamp and tangent to vertical circle, . . . . .	15 00
Stadia hairs, fixed, . . . . .	3 00
" " adjustable, . . . . .	8 00
Reflector plate, . . . . .	4 00
Diagonal eye piece attachment, . . . . .	8 00

When side telescope revolves independent of centre telescope, the vertical arc can be read more safely, being able to sight both lines without change of telescope.

When side telescope and counterbalance are detached, the instrument becomes No. 6 or No. 7, with level to telescope and vertical arc.

### No. 15; or MINING TRANSIT No. 2.

LAKE SUPERIOR PATTERN.

Weight, without tripod, 8½ lbs.

This instrument has one side telescope, with full circle, revolving vertically, and an upper telescope revolving horizontally, with vertical arc.

It is capable of measuring vertical and horizontal angles of any two slopes at one observation, without changing position of either range.

UPPER SEMI-CIRCLE, diameter 8 inches, graduations on silver to minutes.

Level to telescope, with clamp and tangent.

Vertical arc.

SIDE TELESCOPE.

Vertical circle, diameter 6½ inches, graduations on silver.

Two verniers, reading minutes.

Level to telescope.

Tangent, . . . . . \$350 00

## No. 16.

## MINING TRANSIT No. 3.

Weight, 10 lbs.

*This instrument is same as Transit No. 10. It is designed for such Engineering as needs a light, portable instrument. In workmanship, graduations and proportionate strength, it is as reliable as larger instruments, principal difference being in weight. It has simply, in construction, the disadvantage of smaller circle and smaller needle. We consider it a most convenient Mining Transit.*

It is equal to performance of all the ordinary duties of Railway work.

The centres are longer than the centres of the usual larger instruments of the country, being over three inches. The telescope has object glass of one inch opening, and seven inches focus, with power either of inverting or erect eye piece of from 9 to 14. As usually constructed for mining purposes, it has the inverting telescope, affording extra light, larger field and shorter telescope, for same focal length of object glass.

The verniers are wide, extending to edge of plate, to allow extra amount of light. They have advantage of being so placed that the Engineer can read the plate without changing his position, and risking the disturbance of the instrument.

Long centre.

Two outside verniers, reading minutes or decimals.

Needle,  $3\frac{1}{2}$  inches.

Graduations,  $4\frac{3}{4}$  inches.

Tangent to plates.

Vertical adjustment to telescope.

Eye piece, either inverting or erect.

Shifting tripod.

Screws pack in box,

Improvement for Obviating Error of Parallax, . . . . . \$170 00

## Extra:

Gradienter attachment, including level to telescope, . . . . .	\$40 00
Level to telescope, with tangent or opposing screws, . . . . .	25 00
Vertical arc, . . . . .	15 00
Graduated to read 20 seconds, or 30 seconds, . . . . .	10 00
Both erect and inverting eye piece. . . . .	10 00
Stadia hairs, fixed, . . . . .	8 00
“ “ adjustable, . . . . .	8 00
Reflector plate, silver, . . . . .	4 00
Diagonal eye piece attachment, * . . . .	8 00



**MINING TRANSIT No. 4.**

The principal novelty in our Mining Transits is in the arrangement of the Inclined Standards, by which the Engineer is enabled to range the telescope to a vertical line. The result is accomplished without any additional telescope, while the line of collimation remains on line passing through the centre of instrument; consequently all measured horizontal angles have their vertices over the centre point, and no correction for offset is necessary, avoiding the inconvenience and liability to error of double telescopes. The centres of instrument, as made by us during past six years, being much longer than those of other makers, holds the overbalance of standards steady, while the details being arranged to decrease this overbalance, it does not affect the working of the instrument. It can, if desirable, with a slight addition of weight, be entirely destroyed.

The inclined standards afford a much less obstructed view of the vernier, and the improved vernier, patented by us, secures an accuracy of reading hitherto extremely difficult to obtain.

The PATENT TELESCOPE forms a desirable addition, for these reasons:

- 1st, That it is calculated to retain adjustment more perfectly.
- 2d, In the important requisite that the working parts are completely enclosed, thus being protected from dust, dirt and moisture.
- 3d, That the telescope always remains the same length, and always balanced.

Our GRADIENTER ATTACHMENT measures (where the gradient is not too steep) the inclination *with accuracy and speed*, besides distances and differences of level. For a more detailed account of this Attachment, we would refer to our description of Gradienter.

The minor details of instrument, such as position of verniers to one side of standards, so decidedly preferable where the Engineer is working in confined positions, and so much more favorable for throwing light upon graduations; the dust ring cover to plates, similar to our larger instruments; and the more secure arrangement for attachment to tripod, are such as to recommend it to favorable consideration.

The STEEL CHAIN TAPE, strong, durable, and but little liable to injury, is the best calculated of all for underground or surface work.

The CANDLE LAMP PLUMMET is, in cases, superior to our MINING LAMP PLUMMET, in that it is cleaner, more portable and compact, and can be packed in same box as instrument.

With our Sliding Tripod, Short Tripod, Mining Slide Target Rod, and other improvements, we believe we have supplied the important requisites of the Mining Engineer's outfit.

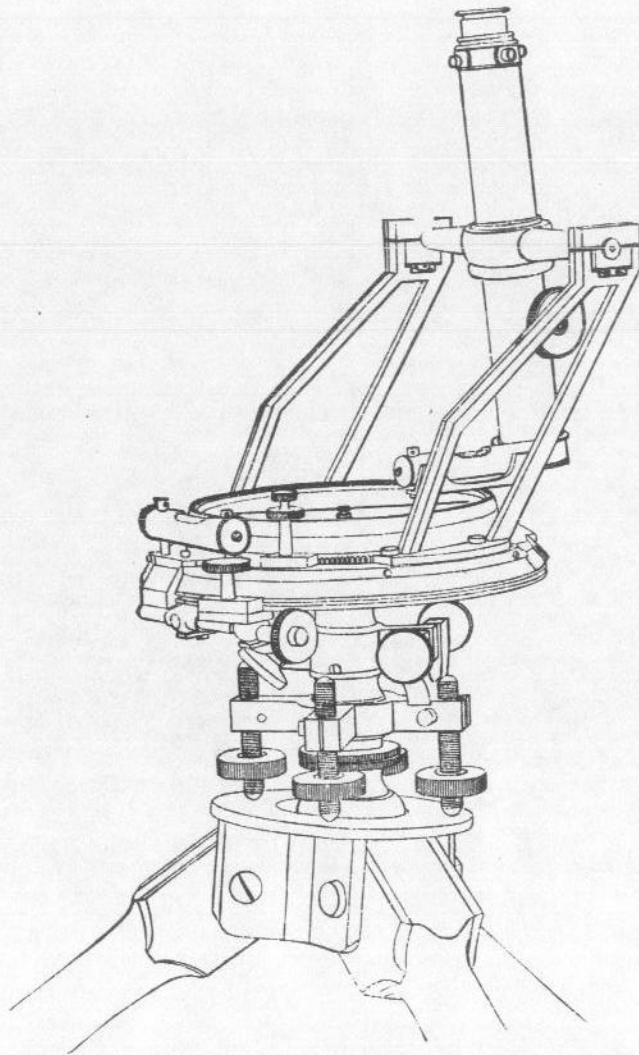

**YOUNG'S**  
Improved Mining Transit No. 4.

Young & Sons,  
PHILADELPHIA.

## PRICE LIST IMPROVED MINING TRANSIT.

*These Instruments have Inclined Standards (patented); Improved Verniers (patented), Improved Telescope, erect (patented); they have also most of the improvements we have placed upon our City Transit.*

PLAIN, Needle $3\frac{1}{2}$ inches Graduations $4\frac{3}{4}$ in., dimensions as No. 10,	\$185 00
" " $4\frac{1}{2}$ " " $6\frac{1}{4}$ " " No. 6,	215 00
" " 5 " " $6\frac{3}{4}$ " " No. 6,	225 00
<b>Extra:</b>	
Gradienter Attachment, including level on telescope, . . . . .	\$40 00
Level on Telescope, with tangent or opposing screws. . . . .	25 00
Vertical Arc, . . . . .	15 00
" Circle, . . . . .	18 00
Graduations to read 20 or 30 seconds, . . . . .	10 00
Stadia Hairs, fixed, . . . . .	3 00
Reflector Plate, Silver, . . . . .	4 00
Diagonal Eye Piece, . . . . .	8 00

## ADDITIONS TO MINING TRANSITS.

### EXTENSION TRIPOD.

Legs to shorten to one-half usual length. Two clamp screws to each leg. The clamping arrangement superior and firmer to those heretofore made.

This form of tripod has been made by us for thirty-five years, and has given most general satisfaction. The change in clamping arrangement, lately made, adds to its efficiency.

Tripod, to accompany instrument in place of regular tripod, extra, . . . . .	\$10 00
Single extension leg to tripod, in place of regular leg, . . . . .	5 00
Full extension tripod, in addition to regular one on instrument, . . . . .	20 00

### HALF LENGTH TRIPOD.

The usual tripod legs are halved and screwed together firmly in centre. When lower half is unscrewed, the upper presents a sharp pointed steel shoe.

The tripod is not so heavy as extension tripod, and is firmer when at full length; but is not as convenient, perhaps, in setting instrument on irregular ground.

Full tripod, in place of regular tripod, extra, . . . . .	\$12 00
Full tripod, in addition to regular tripod, . . . . .	15 00

### REFLECTOR PLATE.

Solid silver, to attach to object glass to illuminate cross web, . . . . .	\$4 00
--	--------

### MINING LAMP AND PLUMMET.\*

#### GERMAN STYLE.

This plummet is made large, with upper part hollow, to receive oil and form lamp. It is suspended directly to sides, or by a gimbol ring, and hung from a point in the roof of the mines. The sight is taken to centre of flame.

Single lamp, packed neatly in box, . . . . .	\$13 00
Two lamps, packed in box, . . . . .	25 00

\* We believe the first of these lamps in this country were made by us, for Eckle B. Coxe, M. E., from drawings furnished by him.



**MINING TRIPOD LAMP.**

This arrangement, lately designed by us, consists of a small tripod, with shifting movement, carrying a lamp, to which a plummet is attached. This lamp is set directly over point, and can be clamped there, the legs of tripod preventing any more shifting than in instrument.

Single tripod, . . . . .	\$22 00
Double " . . . . .	40 00
With attachment to place a slit tangent in position, with lamp behind to illuminate opening, extra, each, . . . . .	5 00

**MINING LAMP HOLDER.**

Similar to the German, by means of which the lamp can be so placed as to illuminate graduations in a convenient manner, . . . . \$16 00

**DOUBLE MINING TRIPOD.**

The tripods have attachments whereby the instrument and lamp, or illuminated slit target, are exchangeable, so that in sighting forward the target is placed in proper position, the instrument taken from tripod and moved into forward tripod, while lamp target is substituted on one left by instrument.

Price, . . . . . \$12 00 to \$30 00.

**MINING ROD AND TARGET**

Is our ordinary slide rod reduced in length to either 3, 4 or 5 feet, with slide to open 5, 7 or 9 feet.

The principal difference is in target, along the centre of which we cut a slit. The clamp is held behind target, and the cross wire readily subdivides this,

\$15 00

We believe the arrangement advantageous in ordinary rods, making a much better object to sight at when rod is between sun and instrument than the usual lines.

**MINING LAMPS, for Engineer's use in Mines.**

We now\* make these lamps of zinc, which keeps cool longer than copper, \$1 50.

\* At suggestion of T. McNair, Esq., Mining Engineer, Lehigh Valley R. R. Co.

No. 17.

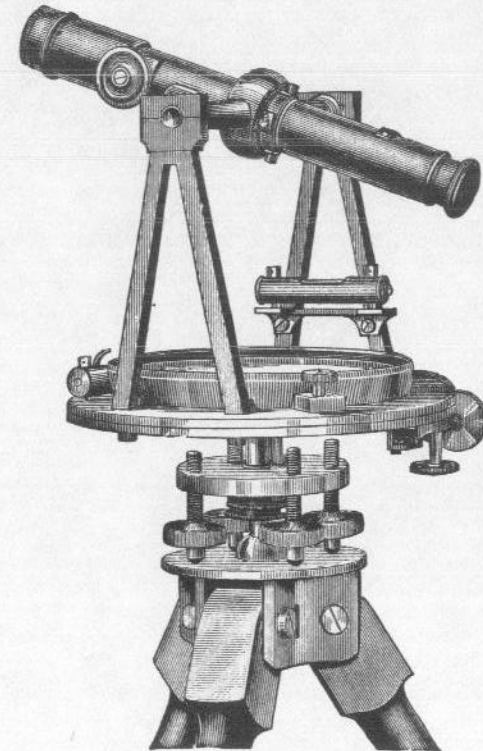
**SURVEYOR'S TRANSIT.**

Weight, . . . . . 16 lbs.  
Power of telescope, 18.

We have endeavored in this to supply an instrument of first class workmanship, in which the needle readings can be checked by graduations of plate, which shall have a fine telescope, and shall not be readily placed out of repair.

The telescope plates, standards, needle and levelling screws are same as on our No. 4 Transit; the tripod is somewhat lighter.

There is but one centre, flat conical, and while this is not as convenient to read angle with plates, it secures the instrument withstanding rougher usage.

Needle, 5 inches.	
Tangent to plates.	
Outside vernier, reading minutes,	
Improvement for Obviating Error of Parallax, . . . . .	\$180 00
Extra:	
Level, with opposing screws to telescope, . . . . .	\$22 00
Vertical arc, . . . . .	12 00
Variation plate for needle, . . . . .	10 00

*The boxes are furnished with plummet, reading glass, levers, &c.*

No. 18.

## VARIATION TRANSIT.

Weight, . . . . .	14 lbs.
Power of telescope, 18.	

Consists of instrument similar to the Surveyor's Transit, except that it has not the plate for reading horizontal angles, but in its place one for laying off variation of needle.

The tripod is made somewhat lighter, and frequently furnished with compound ball and socket, and levelling screws similar to Solar Compass.

Needle, 5 inches.	
Outside vernier for variation,	
Improvement for Obviating Error of Parallax, . . . . .	\$105 00

No. 19.

## BURT'S SOLAR COMPASS.

This beautiful instrument, unquestionably the greatest invention in nature of instruments, deserves to be more widely known and more properly appreciated. The mineral deposits, with their local magnetic attractions, of the Lake Superior country, where it was found impossible to survey the government lands by any known method, the expense of which would not forbid its use, gave rise to the invention of Solar by Burt.

Since its first introduction it has been the only instrument allowed in running the lines on government public land surveys, the use of other instruments being confined to sub-divisions of Solar work.

The principle consists in a practical scientific application of the principles which govern the motion of the sun, that when instrument is placed in adjustment, and the sun's image brought to a certain place, the instrument must necessarily be in the meridian. This is indicated by zeros of horizontal plates, and any other angle can be read off by graduated plates.

Solar work can only be performed in clear weather; the instrument is, however, furnished with needle and graduated plates.

As first made the Solar was without tangent screws, and with an ordinary ball and socket motion being made, in accordance with Mr. Burt's judgment, as simple as possible for use in the wooded brush country where the government surveys were then made. Since then, and with progress of surveys into more open country, the tangent screws and the transit tripod have been added.

When weather is clear the Solar Compass works with much greater rapidity than either compass or transit. With ordinary care, and instrument in adjustment, its result should not vary in rapid work more than from one to two minutes from correct line, a result unattainable in the ordinary compass, and requiring careful work to ensure in long continued lines with transit.

The original manufacturers of the Solar Compass, our forms of solar construction as designed by us, in consultation with the inventor, have stood the test of thirty years. No material change in shape or proportions have been made by the manufacturers who have attempted this work.

In these, as in our engineering instruments, we find instances where some after 30 years service are doing good work.

By a late improvement in the method of adjustment, we have secured greater accuracy than heretofore.

We make either transit tripod, which is most steady, or compound ball and socket, which works more speedily.

The method adopted of attaching telescope in line of centre of compass seems to meet more approval than any other. The telescopes are generally inverting, to secure a shorter telescope. We have lately succeeded in producing an erect telescope, light, and of good power and field.

All graduations on silver.	
Tangent to plates, declination and latitude arcs, and needle box for variation.	
All arcs reading minutes, . . . . .	\$260 00
With telescope (detachable) and sights, . . . . .	290 00
Graduations on arcs to 20 or 30 seconds, extra, . . . . .	20 00
Solar, large size, declination and latitude arcs 6 inches radius, readings	
20 or 30 seconds, plain, . . . . .	300 00
With telescope, . . . . .	330 00

## SOLAR TRANSIT.

Our Solar Transit is simply the Solar Compass with telescope, as above.

Of the various attempts to adapt solar work to ordinary transit, we have as yet seen none we consider capable of good work.



## SOLAR TRANSITS.

The trial of several instruments made by us with Solar Attachment of B. Smith Lyman, C. E., with the attachment to instrument as modified by us, having proved satisfactory, we have added the Lyman Solar to the list of our instruments.

We have not changed the general design nor the principles of the instrument, but so modified the attachment that it can be attached or detached at pleasure. This form of the Solar finds its advantage where the larger portion of the work is with the Transit proper. It forms the only complete SOLAR TRANSIT, to which can be attached a telescope of power arranged as to be conveniently used, and to which regular Transit centres for accurate work can be connected.

The objection to it has been the projection of the Solar apparatus beyond the instrument plates, at all times, both in transportation and when not in use for Solar work. By our arrangement the Solar apparatus can be readily detached at any time, and the Transit remain as a regular Engineer's Transit, with its solidity of centres and power of Telescope.

The distinctive marks of Lyman's Solar are, placing the solar parts under the graduated plates, attaching it to the lower plate; and the use of prisms to change the direction of the sun's rays and shorten the length of the lens bar. Its advantages are, greater steadiness of instrument proper in working; more accuracy in angular measurements, and greater telescope capacity. Its disadvantages are, shorter arcs for reading the Declination and Latitude, and less steadiness for Solar parts.

### PRICES.

Attached to our No. 6 Transit. 6¼ in. Graduation.

Plain Transit, with Solar Attachment, . . . . .	\$290 00
With addition of Gradienter, including Level to Telescope, . . . . .	330 00
“ “ Level to Telescope, and Tangent or Opposing Screws, . . . . .	315 00
Vertical Arc to Telescope, extra, . . . . .	15 00

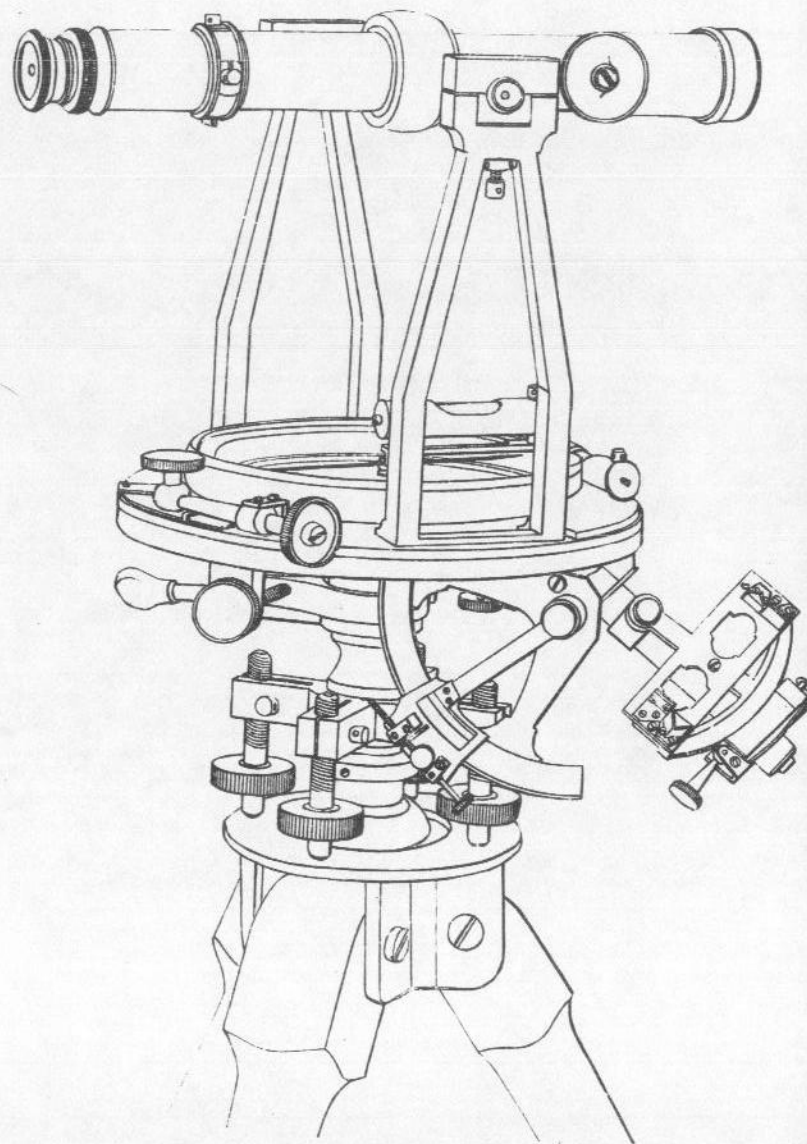

SOLAR TRANSIT. No. 6. Plain.

Young & Sons,  
PHILADELPHIA

LYMAN'S SOLAR ATTACHMENT,  
(DETACHABLE.)

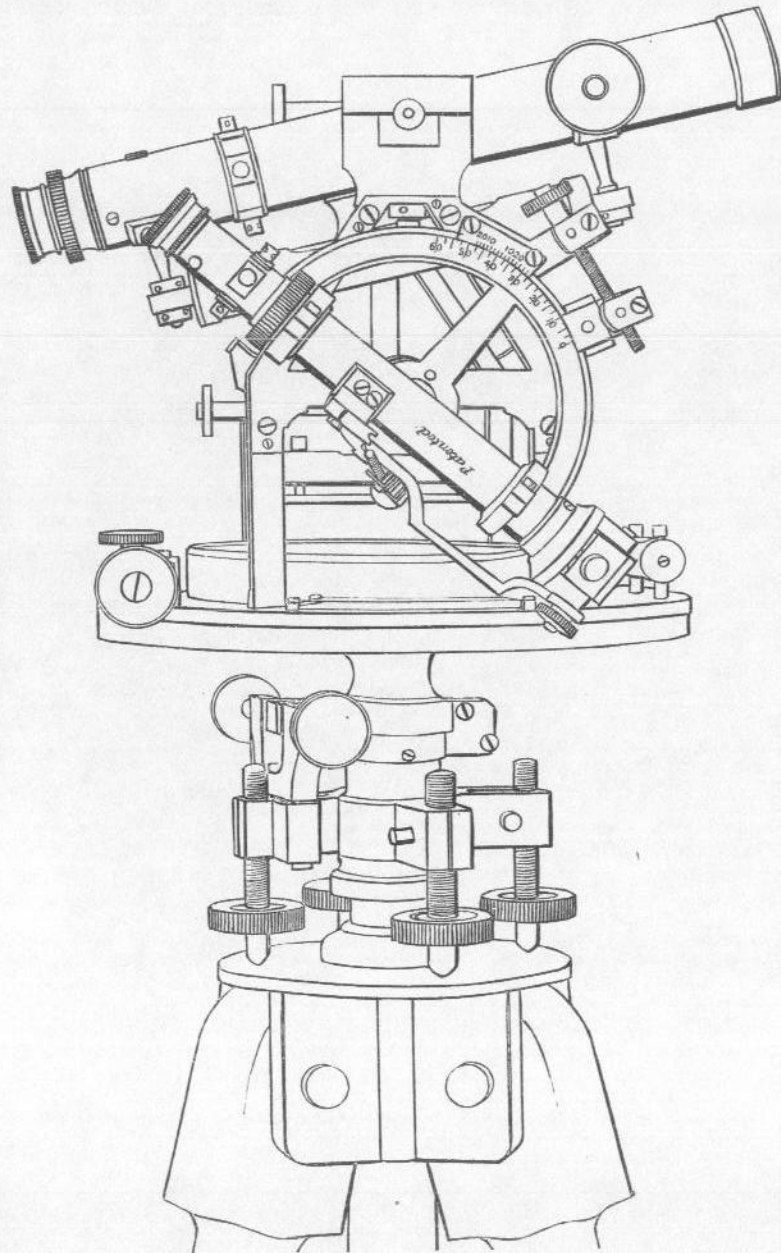

No. 10, or MOUNTAIN TRANSIT.  
SMITH SOLAR ATTACHMENT.

## SOLAR TRANSITS.

We have added to the list of our Instruments the Solar Attachment of Benj. H. Smith, C. E., to which the attention of Engineers and Surveyors, especially those engaged on Government surveys, is called.

The distinctive feature of Mr. Smith's Attachment consists in the use of a Reflector, moved by a declination arm, whereby the sun's image is reflected into the focus of a short telescope, the axis of which corresponds to the polar axis of other forms of solar attachments.

The compactness of this form of solar especially adapts it for attachments to transit instruments, with the ordinary workings of which there is no interference. No counter-poise is required.

The clear limb of the sun's image can be brought between the equatorial wires with greater exactness than can be attained by the ordinary plan of focussing on a silver plate, and hence the meridional result is more accurate.

The polar axis, the vital part of a solar, is longer than in any other form.

Another great advantage which has been experienced by those using this instrument is the facility with which the sun's image can be taken in hazy weather, when the old forms of solar cannot be used.

For the use of U. S. Deputy Surveyors, we recommend our No. 10, or Mountain Transit, as suitable for this Attachment.

### — PRICES —

No. 10 Transit, 3½ inch Needle, 4¾ inch Graduations, Extension Tripod, Level to Telescope, with Tangent Screw or Opposing Screws, Vertical Arc, Smith Solar Attachment,	\$285 00
Smith's Solar Attachment to either sizes of our No. 6,	80 00



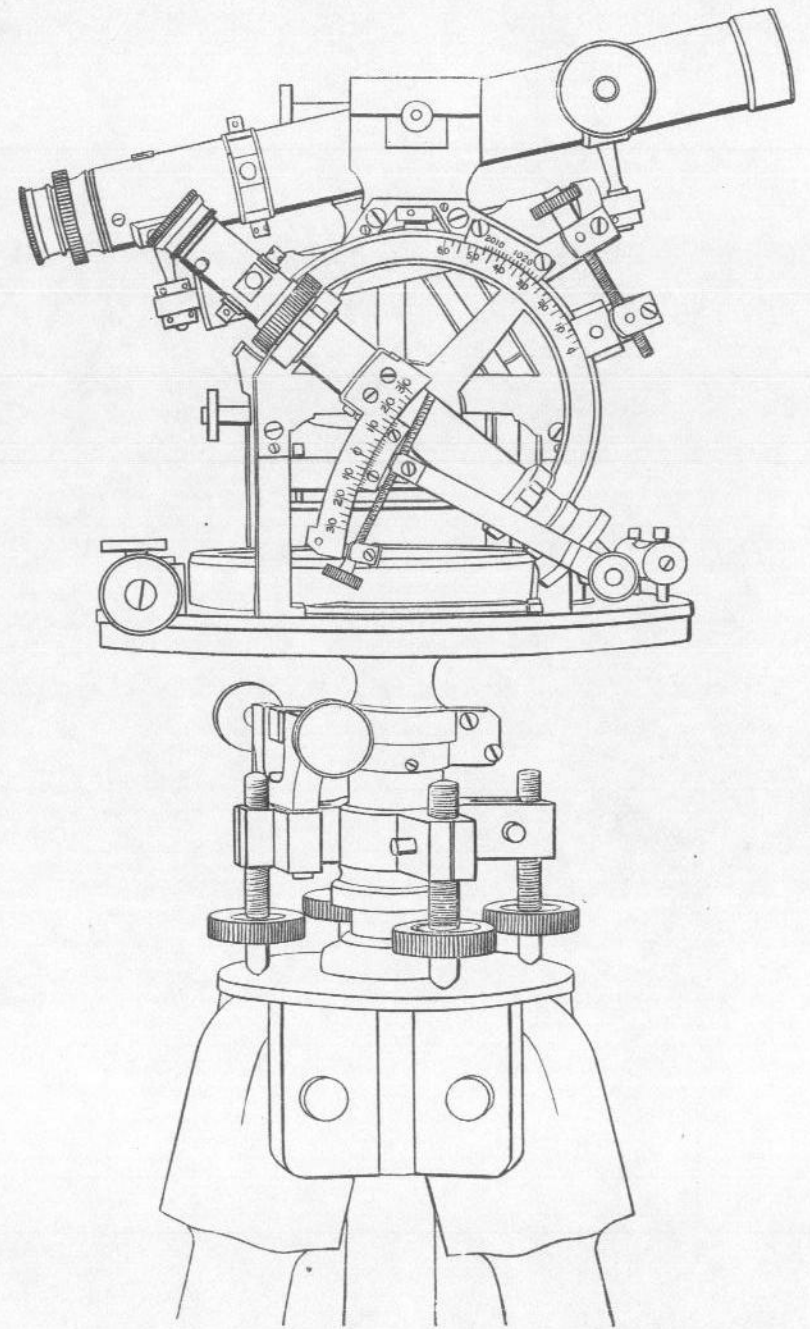

No. 10, or MOUNTAIN TRANSIT.  
SMITH SOLAR ATTACHMENT.

## COMPASSES.

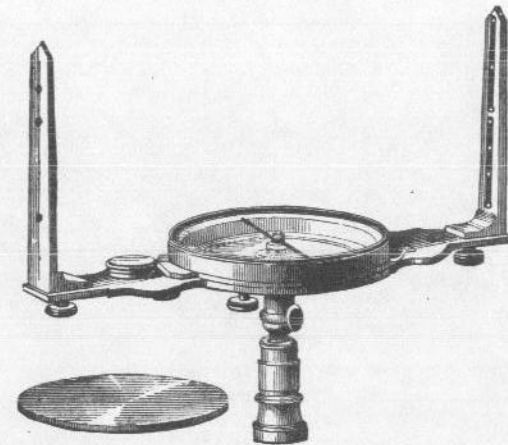

The compasses are furnished with outkeeper cover, and either one circular or two straight levels. The needles are made of selected steel, with greatest depth vertical, to ensure a steadier motion than otherwise, and are of sufficient weight and size to allow them to retain their magnetism, and prevent any little motion of air from keeping them in a tremor, but not sufficient to bear too heavily upon centre pin.

The faces of Compass, except in smaller sizes, are bronzed, to prevent reflection of sun's rays into the eyes. A small silvered ring under the end of needle makes the end fully distinct, and answers the purpose of full silvered face.

Sights are graduated to read angles of inclination. They are made the usual style of slit sights, unless hair ones are especially ordered. When desired, the slits are made wider to assist sight.

All compasses are furnished with our improvement for obviating Error of Parallax.

4 inch needle, 10 inch plate, plain, . . . . .	\$30 00
4½ " " 12 " " " " . . . . .	35 00
5 " " 14 " " " " . . . . .	40 00
5½ " " 15 " " " " . . . . .	45 00
6 " " 16 " " " " . . . . .	50 00

Without variation plate, \$10 extra.

Plate to read full circle, independent of needle, reading minutes, . . . . . 20 00

Plain tripod, . . . . . 8 00

Compound tripod, levelling screws, slow motion to instrument either with or without ball, . . . . . 20 00

Jacob staff, heavy steel pointed shoe, . . . . . 2 50

Chain pins, per set of 11, . . . . . 2 25

" " " " " 11, low led to drop plumb, . . . . . 6 00

" " brass, as not to attract needle, . . . . . 5 00



## PLANE TABLE.

Our complete Plane Table comprises every improvement, some of them new, which can be placed upon it. The gradienter attachment is especially desirable.

The tripods of larger tables are made of open form, strong and light, and giving wide base.

The sizes of board are made as desired.

Board 18 by 24 inches, Engineer's level, tripod, alidade with compass sights, . . . . .	\$70 00
Parallel rule attached, extra, . . . . .	18 00
Alidade, with powerful telescope, paper clamps, . . . . .	200 00
Same, with vertical arc, level to telescope, stadia hairs, gradienter attachment, parallel rule sights, plumbing bar, paper clamps, compass box, . . . . .	300 00

## Young's Self-Reading Level Rod.

This rod, as introduced by us 22 years ago, is by its merits gradually superseding all other rods.

All the faces are recessed and painted clear white. The figures are stamped deeply and then painted, so that they will not rub off. The feet are painted red, the tenths black. The latter figures are six hundredths in size, placed by gauge, generally over centre of tenth division, so that the top and bottom of figure indicates exactly three hundredths above or below. By this arrangement it has been found the top and bottom form data by which on fair distances the hundredth can, without confusion to the eye, easily be read. Placing them central over divisions enables the nearest tenth, for surface levels, to be more easily read. When preferred these figures can be placed with bottom on line.

The rod is 7 feet long, and when readings are desired above this, it slides up and forms a continuous self-reading rod to 12 feet.

The target when used above 7 feet comes against a stop, so that the error arising from this reading being wrong, or of being knocked from its correct reading without discovery, so common in all other rods, is avoided.

In addition to the self-reading characteristic, it is equally a SLIDING TARGET Rod.

By combination of the two qualities the Engineer is enabled in target readings to give the rodman the reading of rod to nearest hundredth at once, so that exact reading may be obtained in one or two shiftings, as well as to know whether any error exceeding one or two hundredths has been made by rodman.

For rapidity of readings on surface levels, for checking the rodman on turning points, and on more accurate readings, we believe it superior to all other forms.

Cross section and similar work on railroading can be performed with at least twice the rapidity and with much greater certainty, besides relieving both the instrument man and rodman of much exhausting irritating labor.

Lately we have introduced several improvements in the mountings, by which the rod is made more durable.

Price, . . . . . \$18 00.

New York Level Rod, Best Pattern, . . . . . \$16 00

## TRANSIT SIGHT POLES,

Made of well seasoned ash, octagonal, with long steel pointed shoes. Every precaution taken to ensure rod remaining straight. Pole divided into feet, and colored red and white alternately.

8 feet, . . . . . \$8 00  
10 " . . . . . 9 00

Pine Sight Poles (not our make) one-half above prices.

## LOCK'S HAND LEVEL.

This little instrument, five inches long by one inch in diameter, intended for reconnoissance, and numerous instances where approximate levels are desired, is held in the hand, the reflected image of bubble brought over wire in tube, and line of level carried out by the eye.

Price, German silver, in case, . . . . . \$12 00  
" Brass, " . . . . . 11 00

## SLOPE LEVELS.

### MINING PATTERN.

Square. Packed in strong wooden box.

4 inch square, . . . . .	\$10 00
4½ " " . . . . .	12 00

### ENGINEER'S PATTERN.

Base 8 inches long, folds into box 2½ inches wide, . . . . . \$13 00

## POCKET COMPASSES.

The usual small Pocket Compass is made so low priced as to be unreliable. In ours, the needle, cap, centre pin, &c., are constructed with as much care as the larger ones, and may be relied upon as far as their size permits. They are such as we have especially made for a number of Mining Companies.

2½ inch needle, folding sights, stops, ball and sockets, cover, graduated to degrees, . . . . .	\$12 00
Same, 3½ inch needle, with variation plate, . . . . .	20 00
Other sizes made to order.	

## PRISMATIC AZIMUTH COMPASSES.

Made in best manner, Needle Card of Alluminum, 3½ inches, . . . . . \$26 00

## NYSTROM'S CALCULATOR.

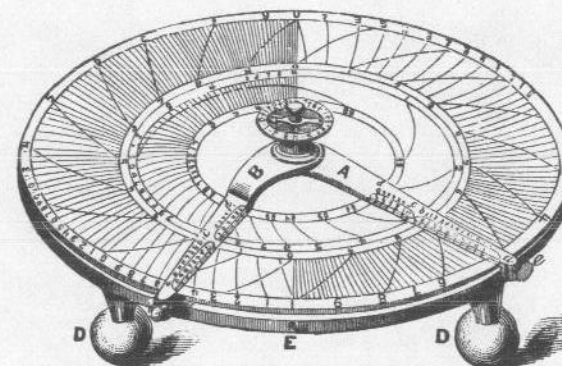

Consists of a plate, on which are fixed two moveable arms, extending from centre to periphery. On the plate are engraved a number of curved lines, in such form and divisions that, by their intersection with the arms, numbers are read and problems solved.

The arrangement for trigonometrical calculations is such that it is not necessary to notice *sine cosino tangent*, &c., operating only by angles themselves, expressed in degrees and minutes. This makes trigonometrical solutions so easy that any one who understands simple arithmetic will be able to solve trigonometrical questions

Calculations are performed by it almost instantly, no matter how complicated they may be, while there is nothing intricate or difficult in its use.

All the calculations in Nystrom's Mechanic's Companion were solved by this instrument, the most severe test, perhaps, to which it could be submitted.

Attention of Engineers, Ship Builders, and all whose business requires extensive calculations, is called to this instrument.

Price, on German silver plate, . . . . .	\$25 00
Box to pack in, . . . . .	2 00



## Draughting Scales and Protractors.

The want of accurate Scales and Protractors being so seriously felt by the Engineer and Architect, we have selected those scales and protractors of our own make which we can recommend for accuracy.

The difficulty in use of scales is in obtaining sub-divisions fine enough for accurate measurements, and at same time not so fine as to confuse the eye.

The Parsons' scale is the only one we know which accomplishes this purpose, and for uses outside the ordinary triangular wood scale, the only one we know of possessing merit.

In protractors the most serious error lies in the centering. The most of the usual forms of circular and semi-circular protractors cannot be relied upon to centre within ten to twenty minutes, while the difficulty of pricking off points correctly is another objection.

The rolling parallel rule and paper protractor finds favor with many Engineers, but there is difficulty in sub-dividing below 15 minutes.

In our opinion the Cleaver Protractor is one capable of greatest accuracy, but for many purposes the steel blade protractor with adjustable head, as made by us, especially when combined with steel or rubber edge, is most convenient and rapid.

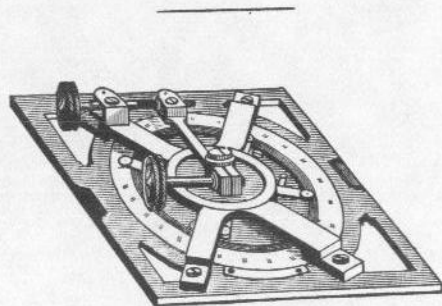

**CLEAVER PROTRACTOR**

Is considered the most perfect Protractor in use. It consists of a square frame, sides made as perfectly at right angles as possible, carrying a vernier, and working around a graduated circle. The graduated circle is fastened to the paper by spring pins, which, by an arrangement, are all sprung down at once. The vernier is adjustable, so that if in process of fastening, protractor springs out of place, the vernier can be reset and placed accurately on line.

The lines are laid off by means of straight edge pressed against side, so that a line can be produced of any length; a triangle being used to pass through points.

Two (opposite) verniers are placed upon instrument to correct eccentricity.

The protractor can be used, being placed on one end, on a board eight feet long, without shifting, and when shifted can, by means of adjusting screws, be placed exactly upon line.

It works, especially when many angles are wanted, with rapidity. It is used almost exclusively in mining regions of Pennsylvania.

5½ inch square, 4 inch circle, clamp and tangent, two double verniers, graduations on silver, . . . . .	\$45 00
6½ inch square, 5 inch circle, . . . . .	50 00
10½ " " 9 " " . . . . .	85 00

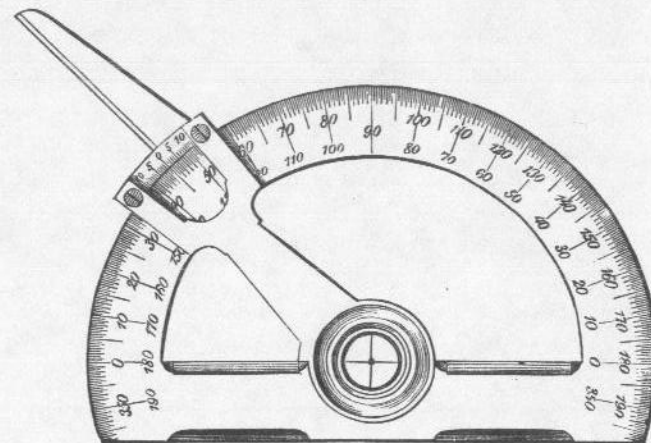

**THE ARM PROTRACTOR.**

Our Semicircular and Circular Protractors are made with care, and may be relied upon as superior to the Swiss—the quality of which has of late years not only deteriorated but become very irregular, requiring much additional work to perfect them.

By using the base of protractor in connection with straight edge on line, or with the T square, pressing the protractor against edge, the errors of eccentricity are also avoided. It works very much the same as the parallel rule and protractor.

Semicircular protractor, German silver, horn centre, 6 inches diameter;	
arm, 8 minutes, . . . . .	\$14 00
8 inches diameter; arm, 1 minute, . . . . .	17 50
10 " " " 1 minute, . . . . .	21 00
Whole circle protractor, 6 inches diameter; arm, 3 minutes, . . . . .	16 00
" " " 8 " " " 1 minute, . . . . .	19 50
" " " 10 " " " 1 minute, . . . . .	23 50

### SPRING ARM CIRCULAR PROTRACTOR.

The object is to prick off all the angles by means of two spring prickers on opposite sides, at one setting of protractor. All the angles are then concentric, and the spring pricker removes the errors of hand manipulation.

The protractor is removed, and angles transferred by means of parallel rule, or straight edge and triangle. It is attended with trouble of transferring angles.

Full circle—German silver, 8 inches; two verniers, reading minutes; two folding arms, with pricking points; tangent screw, adjustment, &c., . . . . . \$80 00  
With double arms in place of pricking points, . . . . . 85 00

### STEEL BLADE PROTRACTOR.

#### SHIFTING HEAD.

This form is used on drawing boards, the edge of protractor resting against edge of board, and the steel blade carrying vernier arm—being moveable to any angle. While edge of board remains straight, this forms a rapid and comparatively accurate method of protracting. Our heads are made larger than usual, so that any irregularity in edges of board will have less effect.

The accuracy of the work is much increased if an extra steel straight edge is fastened along edge of board, so the head of protractor will work upon this edge. These straight edges are then readily fastened to the board with screws.

Protractor 5 inches diameter, 30 inches blade, . . . . . \$20 00  
“ 6 “ “ 40 “ “ . . . . . 22 00  
The verniers read 3 minutes—graduated to read single minutes, extra, . . . . . 8 00

### PARALLEL RULE AND PROTRACTOR.

In using this, base or meridian lines are placed across paper at convenient distances, a straight edge is placed on them, the parallel rule pressed against the straight edge, and the angle laid off on the vernier. The parallel rule allows bringing the arm of protractor directly over point.

The advantage is that the angles are measured from a base line, and the errors of centering are avoided.

Rule, 14 inches; protractor, 8 inches; arm, 10 inches; vernier reading minutes, . . . . . \$25 00  
Packed in case, extra, . . . . . 2 50

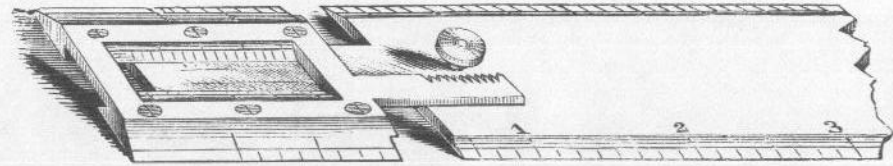

### PARSONS' PATENT VERNIER SCALE.

By this beautiful little arrangement vernier readings can be applied with as much facility to straight line measurements as they can to angular measurements by the transit. No graduations appear on the general divisions practically finer than the tenth of an inch, while readings can be made to hundredths, or, if desired, to the four-hundredths of an inch.

The edge of the German silver scale is graduated, and a moveable vernier placed upon the top, by means of which the initial point is moved any distance desired.

12 inches long, German silver, graduated on two edges, reading any scales desired, . . . . . \$15 00

### ROLLING PARALLEL RULE.

Edges bevelled either in the same or in contrary directions. Two inches wide.

14 inches long, . . . . . \$14 00  
15 “ “ . . . . . 15 00  
18 “ “ . . . . . 18 00  
Morocco or wooden cases, . . . . . 2 75

### POCKET SEXTANTS.

Brass, with cover, which unscrews and forms handle to hold instrument; telescope, reading glass, rack and pinion movement, capable of measuring angles accurately.

Price, . . . . . \$50 00





### THE PAINE PATENT STEEL TAPE

Is a narrow ribbon tape, occupying a larger box than the Chesterman, not so highly tempered, nor so liable to break.

It occupies an intermediate place between the Chesterman and our Engineer's chain tape.

Each foot is graduated into inches and eighths.

The tape is detachable from box.

50 feet, . . . . .	\$8 00
66 " . . . . .	10 00
75 " . . . . .	12 00
110 " . . . . .	15 00
Detachable compensatory handles, graduated for variations of temperature, per pair, . . . . .	4 50
Measures, without cases, graduated, 10 cents per foot.	

### EDDY & CO'S TAPES.—Leather Cases.

50 feet, Metallic, . . . . .	\$2 50	Linen Cord, Enameled, . . . . .	\$2 00
66 " " . . . . .	3 00	" " " . . . . .	2 25
75 " " . . . . .	3 50	" " " . . . . .	2 50
100 " " . . . . .	4 00	" " " . . . . .	2 75

## CHAINS.

STEEL WIRE ALONE IS USED IN MANUFACTURE OF OUR CHAINS.

### ENGINEER'S.

50 feet, No. 7 wire, oval links, . . . . .	\$6 00
50 " " 10 " " . . . . .	5 50
100 " " 7 " " . . . . .	9 50
100 " " 10 " " . . . . .	9 00
50 " " 12 " " . . . . .	7 50
100 " " 12 " " . . . . .	13 00
20 metres, " 12 " " . . . . .	13 00
10 " " 12 " " . . . . .	7 50
20 vara, " 12 " " . . . . .	13 00
10 " " 12 " " . . . . .	7 50

### SURVEYOR'S.

2 pole, No. 7 wire, oval links, . . . . .	\$4 75
2 " " 10 " " . . . . .	4 25
4 " " 7 " " . . . . .	7 00
4 " " 10 " " . . . . .	6 25
2 " " 12 " " . . . . .	6 50
4 " " 12 " " . . . . .	12 00

CHAIN PINS.—See page 65.

## Invention and Introduction of Engineer's Transit.

The first Transit instrument was made during year 1831. It was a long stride in the improvement of Engineering instruments; and that it should to-day retain its almost identical first form, proves the value of its introduction and the good judgment of the inventor.

The English Theodolite, capable of performing the same work, found, if we are to credit the traditions of earlier members of the Engineering profession, but little favor with the American Engineers. Its workings were slow and inconvenient. Few cared to trust the prolongation of a straight line by reversing the Theodolite on its centre, and trusting to the vernier readings; and as few fancied the trouble of reversing telescope on its Y bearings, "end for end." Forgetfulness in fastening of clips resulted in fall of telescope, while if clips were too tight there was the danger of shifting the instrument in fastening, or if too loose the telescope rattled. Such were some of the discomforts attending use of the Theodolite, an instrument well fitted for many purposes, and whose peculiar merits still cause many of our English brethren to cling to its use.

From the Theodolite the change was to the Magnetic Compass. This, in its simplest form, or in its modified form made to read full circle angles independent of needle, was high in favor with many, especially those Surveyors who, from their local knowledge, (and some with naught besides,) were selected to "run" the preliminary lines of railroads. By dint of labor, these Surveyors mastered the intricacies of the vernier, but could never be brought to doubt the superior virtues of compass-sights in seeing past a tree or other obstruction. With the Transit the tree had to come down; they would not undertake to say the staff on other side of tree was in line of cross web, but were sure they could make it "just right" with the line of sights. Nevertheless, though frequently doing close work, the needle would play pranks that produced much trouble; and though to be commended for speed on the preliminary, was rather too uncertain for location.

In the year 1831, the first Transit was made by William J. Young. It was graduated to read by vernier to 3 minutes, it being in early days a favorite idea of inventor that graduations of 3 minutes could be easily read to one minute, and was less perplexing to use. The instrument had an out-keeper for tallying the outs of the chain, and a universal or round level. The needle was about 5 inches; the telescope 9 inches, of low power. The standards were of almost identical pattern now used by some makers. The centre between plates was of flat style, vernier on inside of needle ring, and the plates moved upon each other by rack and

NOTE.—We are desirous of obtaining the first Transit made, or the oldest existing Transit, and offer in exchange for same, a first-class new instrument. Parties having instruments which they suppose may be the oldest, will confer a favor by addressing us.



pinion. The plates and telescope detached from tripod, fastened, we believe, when attached, by a snap-dragon, as in later instruments.

For whom the first Transit was made, the records, as far as we can find them, do not positively show; as well as it can be gathered from them, and from other data, the first one was used on the State works of Pennsylvania, but whether on the Mountain Division or on the Inclined Plane of Columbia R. R., is uncertain.

The distinguished Engineers of the Baltimore and Ohio R. R. also claim the use of the first Transit; and as illustrative of their belief, we append the following extract from RAILROAD JOURNAL of December, 1855:

"The Transit is now in common use in this country, and is a comparatively cheap instrument. Such, however, is not the case in Europe. In England, the old mode is still in vogue, to a great extent, of laying out curves with the use of Ordinates; we are not sure, indeed, that any other course is not an exception."

"Some years since, Mr. Charles P. Manning, an accomplished American Engineer,—now the efficient Chief of the Alexandria, Loudoun and Hampshire Railroad,—went to Ireland, and on the Limerick and Waterford Railway, initiated the method, so common in this country, of laying out curves with the Transit."

"The first instrument of this name was made by Mr. William J. Young, the accomplished Mathematical Instrument Maker, of Philadelphia, for the Baltimore and Ohio Railroad Company, the Engineers of which made the first suggestions modifying the old Theodolite. We have in times past used this instrument, which is much like those made at the present time by the same manufacturer, and is, if we are not mistaken, still in the field."

"Since then, Transits have been little improved, but have been changed in the wrong direction. They are generally much heavier than formerly, containing as much brass and mahogany as one man can well stand under. This great weight is not only useless, but dangerous. Heavy instruments are much more liable than light ones to get out of adjustment on transportation—even in the ordinary field service. They are not a whit steadier in the wind; being generally made with clumsy tripods and large plates, they expose a greater area to the breeze. *If the feet of the tripod be firmly planted*, the instrument is rarely disturbed by the wind. Besides this, a heavy instrument is much more liable to danger from accident in a rough country."

And the following, from same Journal of January 5, 1856:

#### THE FIRST TRANSIT COMPASS.

"In our issue of the 15th of December, 1855, in noticing the field book of C. E. Cross, C. E., we took occasion to state some facts concerning the first Transit Compass, an instrument made by Young, of Philadelphia. We have since then received an interesting letter from Mr. Charles P. Manning, whom we mentioned as having initiated in Ireland the American method of laying out curves. Mr. Manning disclaims the honor in favor of Richard B. Osborne, Esq., an Engineer who received his professional education in the service of the Reading Railroad Company, under Messrs. Moncure and Wirt Robinson (where he finally occupied the responsible position of Chief of the Engineer Department, during the early struggles of that Corporation, in its competition with its rival, the Schuylkil Navigation Company), and from which road he went to Ireland, and took charge of the location and construction of the Waterford and Limerick Railway in 1846."

"Mr. Manning says further: 'I obtained from Mr. Young, and sent to Ireland, probably, the first Transit Compass ever known in that country or in England; and soon afterwards joined Mr. Osborne as his Principal Assistant, for the purpose of aiding him in the effectual introduction, at least upon that road, of the American system of location and construction.'

"We were familiar with these facts when we made the statement which Mr. Manning desires corrected. But our object was not so much to mention the party to whom the credit of introduction was due, as to state a few facts immediately connected with the history of the instrument. Mr. Osborne introduced the instrument into Ireland, Mr. Manning initiated its use among the junior assistants.

"Mr. Osborne was the first to construct an Iron Bridge upon the plan of Howe's Patent Truss—several of which he put upon the W. & L. Railway; and, I believe, he also built and placed upon the same road, the first eight-wheeled, double-truck passenger and freight cars (American plan) that were ever used in Great Britain."

"Mr. Manning gives us a very entertaining sketch of the history of that first Transit, made by Young, of which we remarked that we had in times past made use.

"Twenty and odd years ago—when a mere boy—I saw that instrument upon a lawyer's table, and afterwards in a court-room—a dumb witness in behalf of the patentee. Nineteen years ago, after considerable service in tracing the centre line of the Washington Branch of the B. & O. R. R., it was used in making surveys for the extension of the last named road, westward from Harper's Ferry, and your humble servant carried and used it at that time in Washington County, Maryland, and in Ohio County, Virginia.

"In the last seven years the instrument accompanied me as a duplicate, and was occasionally used upon the location and construction of the B. & O. R. R., through the wilderness, west of Cumberland, and now rests upon its laurels in the office of the Baltimore and Ohio R. R. Co. in Baltimore.

"It was *instrumental* in setting the first peg that was driven for the extension of the B. & O. R. R. west of Harper's Ferry; and it was 'hard by,' and able to do duty, when the last peg was set for completing the track of that road upon the banks of the Ohio river.

"In all material points Mr. Young has never been able to improve upon this original work of his hand, but in some of its minor parts he has effected desirable changes—such as the tangent screws connected with the clamp of the tripod—the substitution of a clamp and tangent screw for the old rack and pinion movement of the two compass plates—the subdivision of degrees into minutes, by an improved graduation of the vernier, &c., &c.

"The original instrument had an index for counting the number of deflections made at one sitting; also a small bubble upon the exterior of the telescope, for the purpose of defining a horizontal line, without resorting to the aid of its companion, the ordinary Level,—but these superfluities were soon thrown aside; and one of its peculiar features was, and is, a Vernier, graduated only to *three* minutes."

Mr. Manning but expresses the facts when he says, that in all *material* points but little change has taken place. The changes that have taken place, have been those called for by peculiar circumstances—modifications, which, while retaining

the characteristics of the Transit, have approached more nearly to the peculiarities of the Theodolite. Transits in after years became divided into the two distinct classes, FLAT CENTRE, as first introduced, and LONG CENTRE, with centres as previously used on Theodolite; but it was not for many years that the long centre—for accurate work the best construction—became other than the exception. It now is the rule, and the flat centre the exception.

Engineers of the present day, unaware of the actual difference in these two styles, and unacquainted with the circumstances of early introduction of instrument, are apt to treat the flat centre with a disrespect it is far from deserving.

For the same strength, the flat centres are far the lightest. Says an experienced and competent Engineer to us, within the few days past, "The first requisite of a Transit is lightness and portability." Judged by these requisites, the Flat centre is the instrument of to-day. But he spoke for his own peculiar branch—railways; and while we are by no means ready to endorse this opinion, we have no hesitation in saying that the circumstances existing at the time of first use of Transit were such, that had the instrument been constructed with the long centre, its usefulness and general introduction would have been very much retarded. The great peculiarity of the first made Transits was their ability to stand hard usage, and non-liability to get out of order under ordinary usage. The centre is a broad metal plate—thick, which it is impossible to bend, or injure in any manner, except by wear; the plates were thick, not easily bent, and the spring vernier, in case of bending of plates, followed their motions and allowed the readings to be made sufficiently accurate to continue work. The rack and pinion had nothing that could break, while the tangents, as then constructed, were equally simple. If the standards, by a fall, were bent so that the telescope would not revolve in a vertical plane, the construction was such, that with the axe as a screw driver, the standards could be loosened, and a piece of paper inserted to correct them.

In fact, the opinion of the writer, with means of observation, and the use of such an instrument, is: *That a flat centred Transit, rack and pinion, and spring vernier, cannot be made totally useless by any accident short of absolute breakage of parts.*

Not so, however, with the long centre. There, the least injury to centres or plates ends the usefulness of the instrument for its work, and it can stand comparatively little rough usage without receiving this injury.

Of the good judgment of the first form of construction, the length of time that many of them have been in use—for some are still doing duty—is the best of evidence. Twenty-five years ago, as rodman, we followed and worked with a flat centre Transit, that to us then looked old enough to retire upon its laurels. So constant had been its use, that its corners, of hard hammered brass, the edges of its standards, and other parts, had then been rounded in carrying against clothing. Ten years afterwards we followed behind it, on the location of one of our main lines across the mountains, where, for a long time, it had been the sole available instrument; and one year ago it was in the shop for repairs, the owner still believing that for Railway work it had no superior. This instrument was light, weighing between fifteen and sixteen lbs.; had seen at least 40 years' service, large part of the time in the hands of Assistants, and in rough, wooded country. We doubt the possibility of a long centred instrument leading an equally long life.

While in charge of some Railway works, we kept in office, where there were several Assistants, both styles of instruments, and the Assistant's choice, in all cases, was for the flat centre.

It is not our intention to argue any superiority in the first form of Transit. It is not the equal, for accuracy and smoothness of motion, of the long centre. Its day of universal application has passed, and its field of usefulness narrowed; but it yet *has* its field and the Engineer will do well in making selections to give it fair considerations. Our desire is simply to do it justice, and to offer for it a slight defence to our younger Engineers, who, having never seen or used it, can know but little of its faults or merits.

In the Transit's early days, no Express, on call, drove to the door, receipted for the boxes, and relieved all anxiety, no matter how many thousand miles away, nor what obscure point was the destination. Instead of this, they had in many cases to be consigned to the top of the stage, or to the Connestoga wagon, unless the destination was near the coast, when the sea became the best route. Thus we find the following extracts, looking at random into the books of shipment:

1833. Aug. 13. Sent, per ship Chester, to F. Beaumont, Natchez, care of Florchell & Co., New Orleans.

1833. Aug. 16. Sent, per brig Mohawk, to Boston, to W. G. Neil, for Boston and Providence R. R.

There is no difficulty in understanding why the call was for a Transit that nothing much short of entire annihilation would render necessary to send back, over its slow, long and uncertain journey, for repairs.

The spread of Internal Improvements in this country had, at this time, fairly commenced, and with it the demand for the new instrument increased rapidly. So great was this increase, and so much did it outgrow the facilities of manufacture, that the inventor was compelled to send to England an order to have the greater part of a limited number of transits made. This was in 1835, and these were the first Transits, or parts of Transits, made in England. About three dozen were thus obtained, the more particular parts being made here. They proved far from remunerative; some few were passable, others more troublesome, requiring alterations and repairs; while a fatal fault to a needle instrument, iron in the metal, was found to exist in nearly a dozen.

Of the latter, most were broken up; several remained in the establishment, in an unfinished condition, until recently, one of the last being taken to adorn the monument of a Civil Engineer, in Laurel Hill Cemetery, Philadelphia.

The earlier manufacture of the Transit instrument was, for want of conveniences, attended with many difficulties. The art of Graduation had as yet made but little progress, and the introduction of the Transit called for nearer approach to perfection. The first Graduating machines were extremely primitive, consisting simply of a circular plate of about 18 inches diameter, upon which degrees and half degrees were marked off, either by mechanical sub-divisions, or from a similar plate. The one in the establishment of W. J. Young, bears the name of ADAMS, Maker, LONDON, and consists of such a plate as we have described.

Such were the means of graduation in 1820. Mr. Young started, as soon as he commenced business, the construction of an engine of 24 inches diameter, worked by the endless screw and treadle; and shortly after introduction of Transit com-



menced another of 26 inches diameter, for finer work, in which a new and important principle of construction for these engines was introduced. A few years afterwards, this same machine was rendered Automatic, and is yet doing active duty, second to none outside of the establishment for accuracy. About the same time, Mr. Edmund Draper constructed a graduating engine, which, amongst those acquainted with it, has a high reputation for accuracy.

The completion of the large 48 inch Graduating Engine, by W. J. Young, which he intended to be the perfect engine of the world, completed a line of Graduating Engines, which, for completeness of range, is certainly not equalled here, perhaps not in any establishment in Europe.

As Transits advanced to perfection, these advances in graduation became necessary. That they were not made at once, but were the result of almost a life of thought, work and patience, and source of expense, is evident from the fact, that from the year 1821 to 1860, or but 10 years before his death, W. J. Young was almost constantly engaged upon the making or perfection of these engines.

Another serious difficulty arose from want of opticians of ability. The first glasses used were imported principally from England. With the slow communication across ocean at that period, it was long before an order given could be received; and the purchase of all glasses to be found here, of proper size and focal length, furnished but a short supply. What was more troublesome, was the next supply differed in size and length from the last. When an inquiry for a larger instrument, or one of different construction, came, the question which determined the practicability of its manufacture, was the capability of making the telescope.

About 1849, an optician named Worth, commenced in New York the manufacture of glasses of telescopes for Engineers' Instruments, and they proving so much better than those otherwise obtainable, the writer of this was sent to learn, under Worth's instructions, the optical art. Before long, arrangements were made, Mr. Young purchased the tools and machinery, and it was removed to Philadelphia, along with the workmen, and connected with his establishment, with which it continued connected for many years, until, from increasing business, the tax on personal attention became too onerous; the tools and machinery were retained, and Mr. Worth placed in position to start for himself. From the optical department, as carried on during this period, came the majority of those now engaged in the manufacture of glasses for Engineering instruments. It gave the impetus which established the business permanently in this country. Fitz, of New York, and one or two others, had been quite successful in making the larger glasses for Astronomical Telescopes, but we believe had not turned their attention to the others.

The Transit instrument having thus been brought nearer perfection, in graduation and optical performance, received but few more changes in construction. The decimal graduation of vernier, suggested at an early day, by S. W. Mifflin, C. E., proved great advantage in the turning off deflection angles for curves, and was adopted by many, notably by the Engineers of Pennsylvania R. R., all of whose instruments were graduated in that manner.

The *loose* vernier and arc, for vertical angles, applied by the writer, about year 1850, was an improvement over the much liable to be injured full circle.

The Shifting Staff-head, patented by W. J. Young, in 1858, was another of those little improvements which increase the value of instrument much.

The many varied uses to which, from progress of science in this country, the instrument has been called, has brought forth instruments of greater delicacy and different constructions, until, to-day, the finest Transit of the conscientious instrument maker is a splendid instrument, not surpassed in its performances by the production of any other country.

Of later minor improvements, some beneficial, some the exploded humbugs of by-gone days, we are not now to speak. The profession have other, perhaps less partial means of discovering them. Our desire is simply to keep from oblivion, the dates and circumstances of introduction of the instrument which has played so important a part in the ever memorable forty-five years of American Railroad construction, and which might, perhaps, be lost in the whirl which has been crowding the Railroad mind ever forward, leave it no time to look back to the earlier laborers.

## ASTRONOMICAL INSTRUMENTS.

---

*We are prepared to manufacture Astronomical Instruments of all classes and sizes. Being the only ones in this country who have attempted the production of finer mechanical work of this class, we would request attention of colleges, other institutions and private parties to our facilities. The work produced by us in its mechanical execution will be guaranteed equal to the best European work.*

*Instruments with circles as large as 44 inches can be graduated on our Engines. We have already through the country, Transit and Meridian circles ranging from 26 to 40 inches diameter of circle.*

## PART II.

---

## DRAUGHTING INSTRUMENTS

AND

## Engineer's Stationery.

---

Few of the articles in this part of the catalogue are of our own manufacture. They are mostly imported, and require a careful selection, examination and overhauling to insure good articles. We make the best selection possible, and by a careful examination and correction insure many of the articles reaching our friends in an improved condition.

Of draughting instruments, the Swiss are the best, as they are more uniform in quality, and of a more general better finish.

The pattern known as Alteneder Patent, the invention of Mr. Alteneder, of Philadelphia, but which are made abroad, and included amongst the Swiss instruments, can be recommended as superior to the others.

The first-class German instruments are, however, generally satisfactory.

To the Engineer desiring first-class case of draughting instruments, we would advise selection of his own, the prices of boxes and instruments given in list enabling him to determine cost.

We have included a few cases of brass instruments, but would earnestly advise, wherever possible, the purchase of German silver. The brass ones may answer some purposes, but for most work will prove unsatisfactory, their price is such as to prohibit a good quality. For this reason we have limited our list.

Our experience in the use of all articles of stationery, enables us to select them with more judgment than usual.

Any desired article, not in following list, will be furnished at current prices.



EXTRA FINE  
Swiss Mathematical Instruments.

GERMAN SILVER.

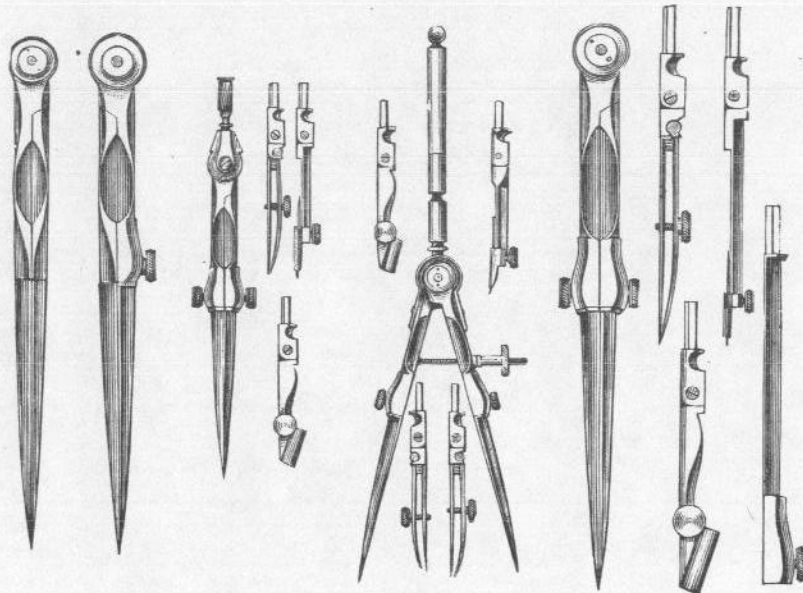

500	506	512	510	514	
No.					
500.	Dividers, plain, 4 to 4½ inches,				\$1 50
502.	" " 5 to 5½ "				1 75
504.	" " 6 "				2 50
506.	" hair-spring, 4 to 4½ inches,				2 25
508.	" " 5 to 6 "				2 50
510.	" 4 inches, with Spring and Set Screw, Needle Point, Pencil Point, and two Pen Points, Ivory Handle,				7 00
512.	" 3½ to 4 inches, with Pen, Pencil and Needle Points,				5 00
514.	" 5½ to 6½ inches, with Pen, Pencil, Needle Points and Lengthening Bar,				6 50

SWISS INSTRUMENTS.

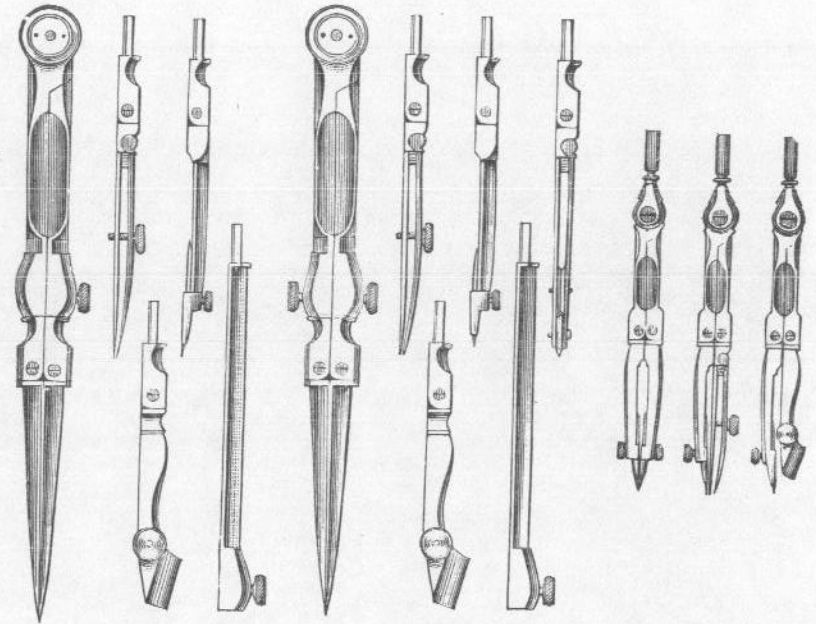

516	518	520	522	524
No.				
516.	Dividers, 6½ inches, Joint in each leg, with Pen, Pencil, Needle Points and Lengthening Bar,			\$6 00
518.	" " " " Joint in each leg, with Pen, Pencil, Needle Points, Lengthening Bar and Dotting Pen,			9 00
520.	" 3½ inches, Joint in each leg, fixed Needle Points,			3 00
522.	" " " " " " " " and Pen,			3 00
524.	" " " " " " " " and Pencil,			3 00
526.	Pocket Dividers, 5 inches, plain, with Metal sheath to protect points,			3 00

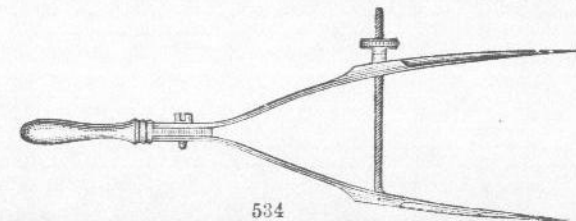

528.	Wholes and Halves, or Bi-secting Dividers, 7½ inches,	4 25
530.	Spring Bow Pen, German Silver,	2 00
532.	" " " " with Pencil point,	3 00
534.	Steel Spacing Dividers, 4½ inches, plain Ivory Handle,	2 00

SWISS INSTRUMENTS.

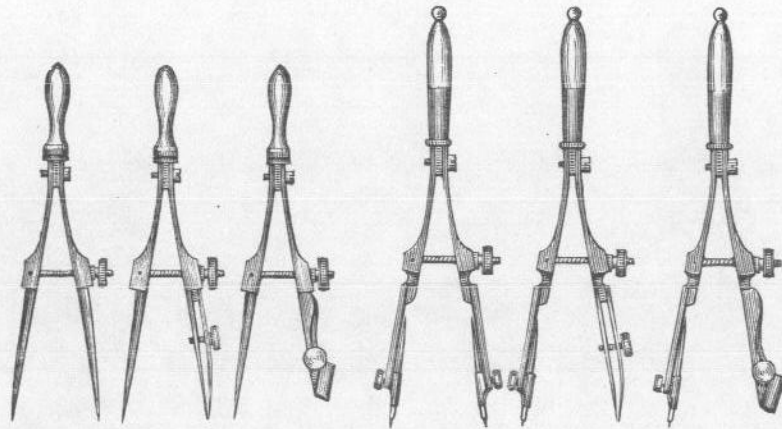

536 538 540 542 544 546

No.								
536.	Spring Steel Spacing Dividers, plain,	3½ ins.,	Ivory Handle,					\$1 50
538.	" " " Pen,	" " " "	" " " "					2 00
540.	" " " Pencil,	" " " "	" " " "					2 00
542.	" " " Dividers,	" " Needle Points,	Ivory Hdle.,					2 50
544.	" " " Pen,	" " " "	" " " "					2 40
546.	" " " Pencil,	" " " "	" " " "					2 40

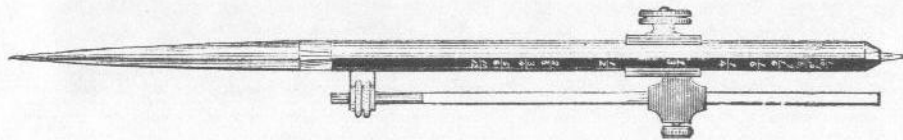

554

548.	Proportional Dividers,	6½ inches,	finely graduated for lines,					8 00
550.	" " " "	9 inches,	finely graduated lines and circles,					12 50
			or lines and polygons,					
552.	" " " "	8 inches,	finely graduated lines and circles,					13 50
			or lines and polygons, with rack movement,					
554.	" " " "	9 ins.,	finely graduated lines and circles, or					15 00
			lines and polygons, micrometer adjustment,					

SWISS INSTRUMENTS.

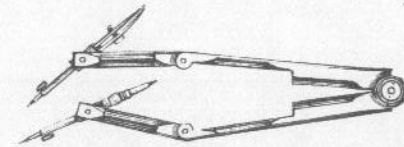

556

No.								
556.	Universal Pillar Compasses, or Pocket Set of Instruments, with	Points to turn,						\$7 50
558.	Universal Pillar Compasses, or Pocket Set of Instruments, with	Points to change,						7 50
560.	Universal Pillar Compasses, or Pocket Set of Instruments, with	Points to change, and Handle to Bow Pen and Pencil, so each	can be used as small instruments,					8 00

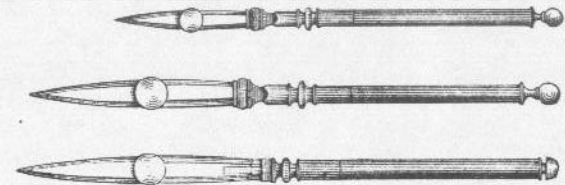

562

562.	Drawing Pen, Joints and Needle Point,	4½ inches,	Ivory Handle,					1 25
564.	" " " "	5½ " " " "	" " " "					1 40
566.	" " " "	6½ " " " "	" " " "					1 60

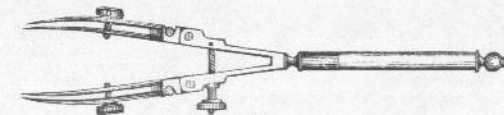

568

568.	Railroad, or Double Drawing Pen,							3 75
570.	Border, or 3-nib Pen,	6½ inches,	for broad lines,					3 75
572.	Curve Pen,							1 50

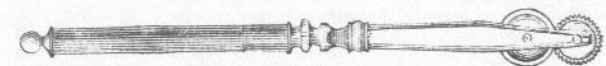

574

574.	Dotting, or Roulette Pen,	1 wheel,						2 00
576.	" " " "	6 " "						3 50
578.	" " " "	3 " "	improved,					3 75
580.	Opesometer, for measuring curve lines,							3 00
582.	Tracer, with Ivory Handle,							1 50
584.	Pricking Point, in holder, Ivory Handle,							2 00



SWISS INSTRUMENTS.

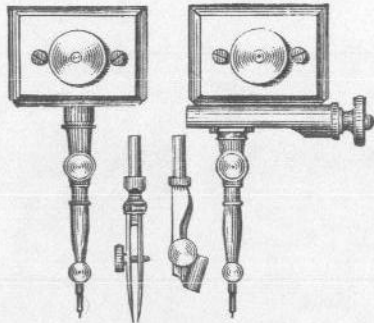

586

- |      |   |        |      |
|------|---|--------|------|
| No.  |   |        |      |
| 586. | Furniture for Beam Compasses, to fit on any straight edge, Needle Points, Pen and Pencil, micrometer adjustment, morocco box,                       | \$8 00 |      |
| 588. | Furniture for Beam Compasses, to fit on any straight edge, Needle Points, Pen and Pencil, adjustment by spring and screw, Morocco box, same, extra, | 10 50  | 1 00 |
| 690. | Furniture for Beam Compasses, with attachment on wheels to stand by itself, Morocco case,   | 13 00  | 2 00 |

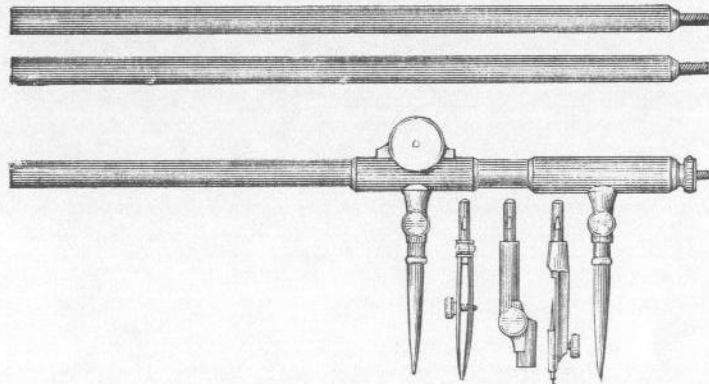

592

- |      |   |       |
|------|---|-------|
| 592. | Beam Compass, German Silver, Tubular Bars, 21 inches, 3 bars, | 10 50 |
| 594. | " " " " " " 36 " 4 "  | 15 00 |
| 596. | " " " " " " 54 " 4 "  | 21 00 |

German Silver Mathematical Instruments,

KNOWN AS

ALTENER PATENT JOINTS.

The excellence of these instruments consists in the joints of the dividers being constructed to prevent irregular motion in the operation of opening and closing.

The sectional view below illustrates the construction of the joint.

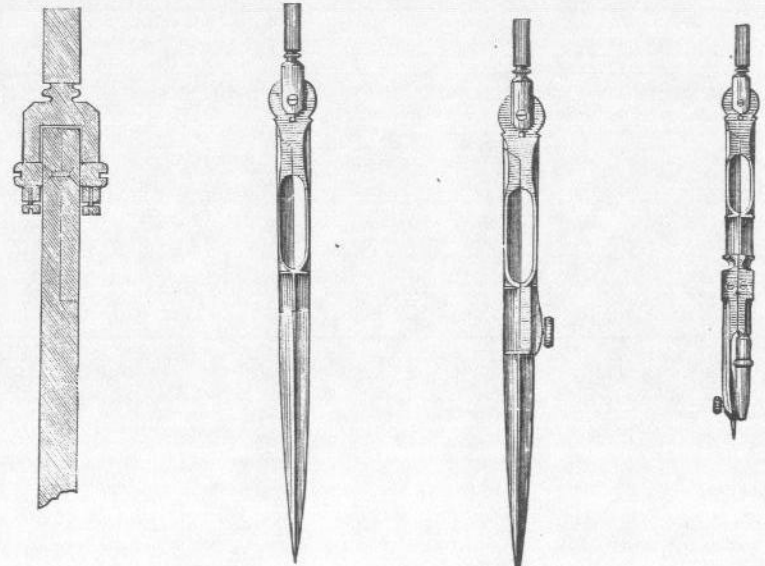

602

608

612

- |      |  |   |    |  |        |
|------|--|---|----|--|--------|
| No.  |  |   |    |  |        |
| 600. | Plain Dividers, 3½ inches,   |   |    |  | \$2 00 |
| 602. | " " 5 "  |   |    |  | 2 75   |
| 604. | " " 6 "  |   |    |  | 3 25   |
| 606. | Hair-spring, 3½ inches,  |   |    |  | 3 00   |
| 608. | " " 5 "  |   |    |  | 3 50   |
| 610. | " " 6 "  |   |    |  | 4 00   |
| 612. | Dividers, 3½ inches, Joints in each leg, Fixed Needle and Pencil Points, | 4 | 25 |  |        |

## ALTENERER'S INSTRUMENTS.

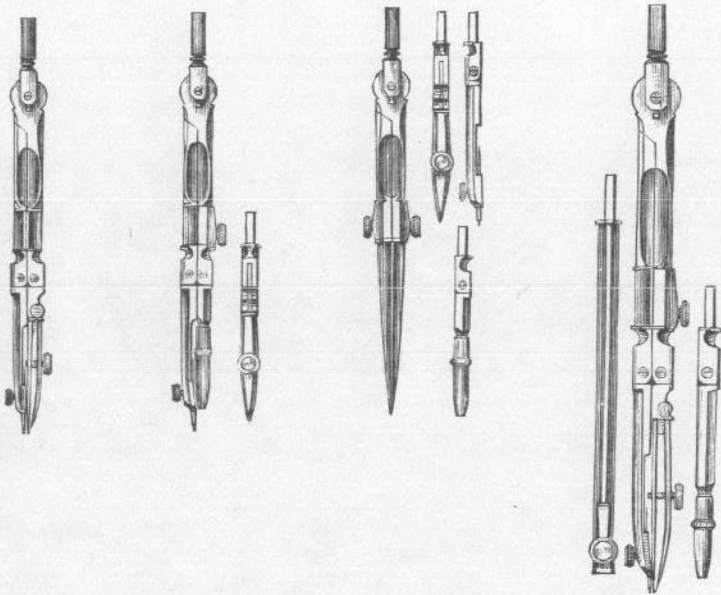

614	616	618	620	
No.				
614.	Dividers, 3½ inches,	Fixed Needle and Pen Point,		\$4 75
616.	“ 3½ “	“ “ and with Pen and Pencil Points,	6 25	
618.	“ 3½ “	with Pen, Pencil and Needle Points,	7 50	
620.	“ 5½ “	with Fixed Needle Point, and with Pen and Lengthening Bar,	7 50	

These instruments have generally the Patent Improved Pencil Points, and are made to fit A. W. Faber's leads, such as are used on Artists' pencils. It avoids the difficulty of finding a suitable pencil, and permits a much better shape to pencil leg.

*These instruments are not made up in boxes, except to order, when they are generally combined with the Swiss Instruments. For prices of Boxes, see folio 11\*.*

## CASES OF EXTRA FINE SWISS INSTRUMENTS.

*Our patrons are reminded that these boxes are not the cheap warped affairs usually imported, but are made especially for us, of well seasoned lumber.*

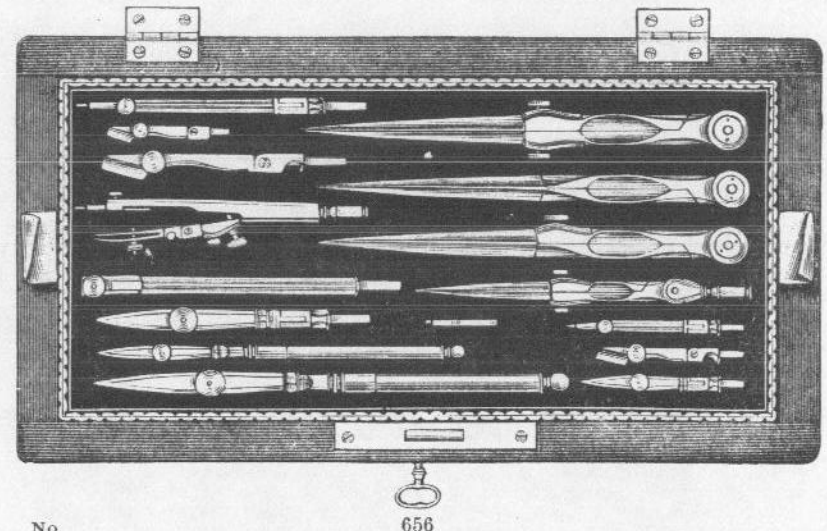

No.	656	
650.	Morocco Box, Rounded Corners, containing	
	Set of Instruments,	No. 514,
	Plain Dividers,	“ 502,
	Drawing Pen,	“ 564,
		\$14 00
652.	Beautifully Polished Walnut Box, 9½ inches long by 6½ inches wide, with Well, Lock and Key, containing	
	Set of Instruments,	No. 514,
	Plain Dividers,	“ 502,
	Steel Spacing Dividers,	“ 536,
	“ Bow Pen,	“ 538,
	“ “ Pencil,	“ 540,
	Drawing Pen,	“ 564,
		24 50
654.	Beautifully Finished Walnut Box, 9½ inches long by 6½ inches wide, with Well, Lock and Key, containing	
	Set of Instruments,	No. 514,
	“ “	“ 512,
	Bow Pen, German Silver,	“ 530,
	Drawing Pen,	“ 562,
	“ “	“ 564,
	6 inch Triangular Scale,	
		29 00



## SWISS INSTRUMENTS.

No.			
656.	Same as 652, with addition of Hair-spring Divider,	No. 508,	\$32 50
658.	Engineer's Pocket Set, in Morocco Case, Sliding Cover, well bound, closely packed:		
	Universal Pillar Compasses, with Handle to Bow Pen and Pencil,	No. 560,	
	Furniture for Beam Compasses,	" 586,	
	Drawing Pen, either No. 562, 564 or 566,		23 00

The Universal Pillar Compasses, No. 560, are capable of large and small measurements, and of describing circles from over 8 inches to the smallest diameter.

*Instruments packed in this style are convenient where Engineer's duties call for work at different points.*

660.	Beautiful Polished Walnut Box, 13 inches long by 6 inches wide, with Well, Lock and Key:		
	Set of Instruments,	No. 516,	
	" "	" 510,	
	Plain Dividers,	" 502,	
	Hair-spring Dividers,	" 508,	
	Bi-secting Dividers,	" 528,	
	Furniture, for Beam Compasses,	" 586,	
	Drawing Pen,	" 562,	
	" "	" 566,	
	" " Red Ink	" 740,	
	Road Pen,	" 568,	45 00

662. Polished Walnut or Rosewood Box, Rounded Corners, 13 inches long by 6 inches wide, with Well, packed for Colors, &c. Drawer in bottom:

	Set of Instruments,	No. 516,	
	" "	" 510,	
	Plain Dividers,	" 504,	
	Hair-spring Dividers,	" 508,	
	Steel Spacing Dividers,	" 534,	
	" " "	" 536,	
	" Bow Pen,	" 538,	
	" " Pencil,	" 540,	
	Bi-secting Dividers,	" 528,	
	Furniture, Beam Compasses,	" 586,	
	Drawing Pen,	" 562,	
	" "	" 564,	
	" "	" 566,	
	" " Red Ink,	" 740,	
	Road Pen,	" 568,	
	Roulette Pen,	" 574,	
	Curve Pen,	" 572,	70 00

## SELECTION OF SWISS MATHEMATICAL INSTRUMENTS.

The wants of Engineers and others using the better class of Draughting Instruments are so varied that it is difficult to arrange cases of same satisfactorily. We advise purchasers to make selection of such as they desire, and have them packed to order. The following schedule will enable them to determine precisely the cost.

The boxes are made in best style—carefully packed—in well seasoned wood, the difference in cost depending upon details of finish.

Brushes, Pencils, Colors and Scales packed in Well of box.

## BOXES, without Instruments.

Morocco Box, holding 10 pieces or less,	\$2 50
Each additional piece,	25
Walnut or Rosewood Box, holding 10 pieces or less, with Well for Colors, &c.,	\$5 00 to 8 00
Each additional piece,	30
Walnut or Rosewood Boxes, with Well for Colors, &c., Rounded Corners, Drawer, holding 10 pieces or less,	10 00 to 15 00
Each additional piece,	30

The pieces are to be counted as each *separate* part requiring packing in tray. Pieces that are packed in well are not counted.

Tin Boxes, with lock, for holding Case of Instruments, and loose articles,	Small size, \$2 00 Large " 4 00
---	------------------------------------

# FINE German Mathematical Instruments.

GERMAN SILVER.

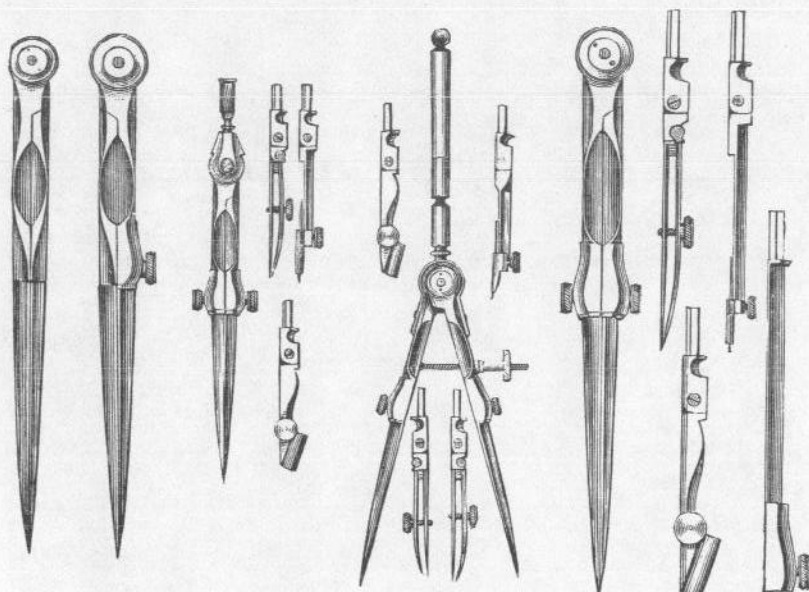

700	706	714	718	716	
No.					\$
700.	Plain Dividers, 4 inches,				70
702.	" " 5 "				80
704.	" " 6 "				1 00
706.	Hair-spring Dividers, 4 inches,				1 25
708.	" " " 5 "				1 80
710.	" " " 6 "				2 50
712.	Plain Dividers, German Silver, with Handle, 3 inches,				1 70
714.	Dividers, 3½ inches, with Handle, Pen and Pencil Points, extra Needle Points,				2 50
716.	" 5½ inches, with Pen and Pencil Points, Lengthening Bar, extra Needle Points,				3 00
718.	" 4 inches long, with Spring and Set Screw, Needle Point, Pencil Point, and 2 Pen Points, Ivory Handle. <i>This No. is Swiss make,</i>				7 00

## MATHEMATICAL INSTRUMENTS OF GERMAN SILVER.

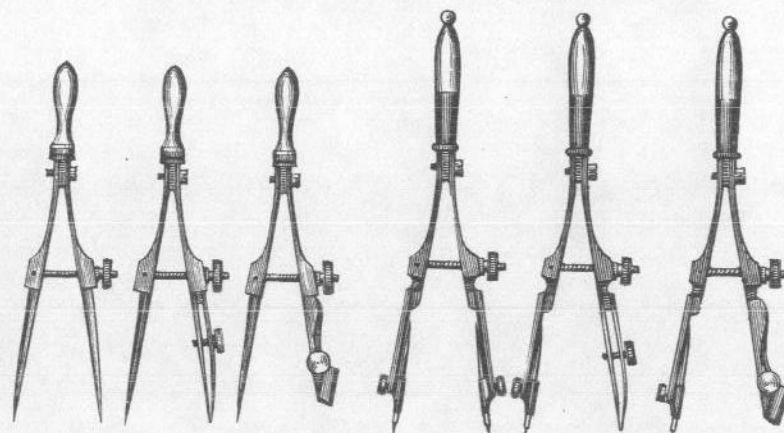

720	722	724	726	728	730	
No.						\$
720.	Spring Bow Dividers, Ivory Handle,					1 50
722.	" " Pen, " " " " " " " "					1 50
724.	" " Pencil, " " " " " " " "					1 50
726.	" " Dividers, Needle Points, Ivory Handle,					2 50
728.	" " Pen, " " " " " " " "					2 40
730.	" " Pencil, " " " " " " " "					2 40
732.	Bow Pen, German Silver, with Spring and Adjusting Screw,					1 75
734.	" " " " " " " " " " and Pencil Point,					2 50

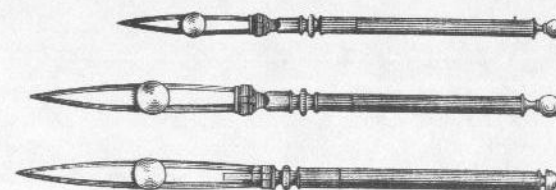

736		
736.	Drawing Pens, 4½ inches, with Joints, Needle Point, Ivory Handle,	75
738.	" " 5½ " " " " " " " "	80
740.	" " German Silver Points, for Red Ink,	90

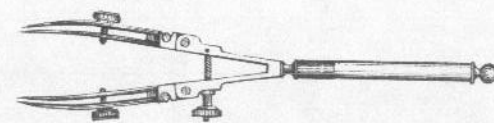

742		
742.	Railroad, or Double Drawing Pen,	2 25
744.	Border Pen, for heavy borders,	8 25



MATHEMATICAL INSTRUMENTS OF GERMAN SILVER.



746

No.					
746.	Roulette Pen, for dotting lines,				\$2 00
748.	Curve Pen, for drawing curves,				1 50
750.	Hatching Pen, 5 inches, 3 Blades,				1 75

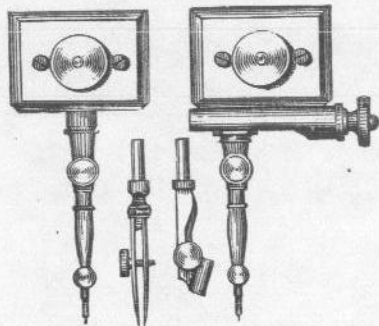

752

752.	Furniture for Beam Compasses, with Adjusting Screw, in Morocco case.	5 00
754.	German Silver Paper Tacks, flat heads, per doz..	60
756.	" " " " " larger, "	1 00
758.	Steel Paper Tacks,	80
760.	Horn Centre, German silver rim,	35
762.	" " " no "	15

*These Instruments are superior in quality to those ordinarily in the market.*

Instruments can be selected and packed in boxes at prices same as for Swiss Instruments.

CASES OF  
Fine German Mathematical Instruments.

GERMAN SILVER.

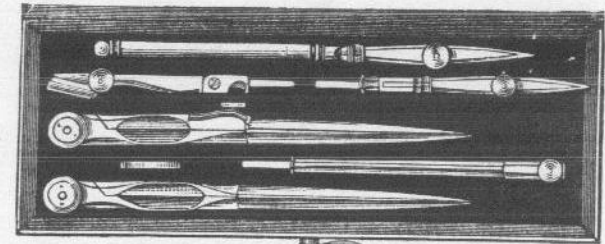

800

No.				
800.	Morocco Case, containing			
	5½ inch Dividers, with Pen, Pencil Points and Lengthening Bar,			
	5 inch Plain Dividers,			
	Drawing Pen, Ivory Handle,			\$5 00
802.	Morocco Case, containing			
	Dividers, 5½ inches, with Pen, Pencil, &c., No. 716,			
	" 5 " Plain, " 702,			
	Drawing Pen, Ivory Handle, " 736,			6 75
804.	Same as 802, with addition of			
	Spring Bow Pen, " No. 732,			8 50
806.	Same as 804, Wooden Case, with Tray,			10 00
808.	Morocco Box, containing			
	Dividers, 5½ inches, with Pen, Pencil,			
	Needle Point and Bar, " No. 716,			
	" 5 inches, plain, " 702,			
	Spring Dividers, " 720,			
	" Bow Pen, " 722,			
	Drawing Pen, " 738,			
	Fine Ivory Protractor Scale,			14 00

## GERMAN SILVER MATHEMATICAL INSTRUMENTS.

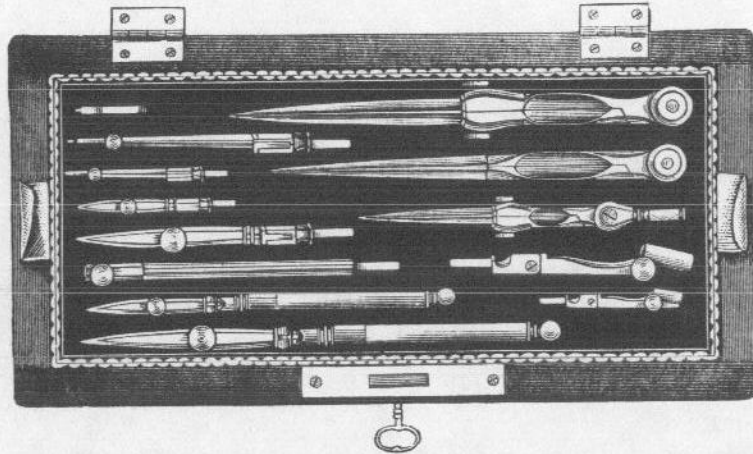

810

- No.  
810. Polished Walnut Box, with Well, Lock and Key, containing
- |  |                      |
|--|----------------------|
| Dividers, 5½ ins., with Pen, Pencil, Needle Points and Lengthening Bar, No. 716, |                      |
| “ 3½ ins., with Pen, Pencil and Needle Points,                                   | “ 714,               |
| “ 5 ins., plain,   | “ 702,               |
| Drawing Pen, 4½ ins., Ivory Handle, Needle Point,                                | “ 736,               |
| “ “ 5½ ins., Ivory Handle, Needle Point,   | “ 738, . . . \$14 00 |
812. Polished Walnut Box, Well, Lock and Key, containing
- |  |                    |
|--|--------------------|
| Dividers, 5½ ins., with Pen, Pencil, Needle Points and Lengthening Bar, No. 718, |                    |
| “ 3½ ins., with Pen, Pencil and Needle Points,                                   | “ 714,             |
| Spring Bow Pen, with Needle Point,   | “ 732,             |
| 1 Drawing Pen,   | “ 738,             |
| 1 “ “ Red Ink,   | “ 740, . . . 17 00 |
814. Polished Walnut Box, Well, Lock and Key, containing
- |  |                    |
|--|--------------------|
| Dividers, 5½ ins., with Pen, Pencil, Needle Points and Lengthening Bar, No. 716, |                    |
| “ 4 ins., plain,   | “ 700,             |
| “ 5 “ Hair-spring,   | “ 708,             |
| Spring Bow Dividers,   | “ 720,             |
| Furniture for Beam Compasses,  | “ 752,             |
| Drawing Pen,   | “ 736,             |
| “ “  | “ 738,             |
| “ “ Red Ink,   | “ 740, . . . 22 00 |

## GERMAN SILVER MATHEMATICAL INSTRUMENTS.

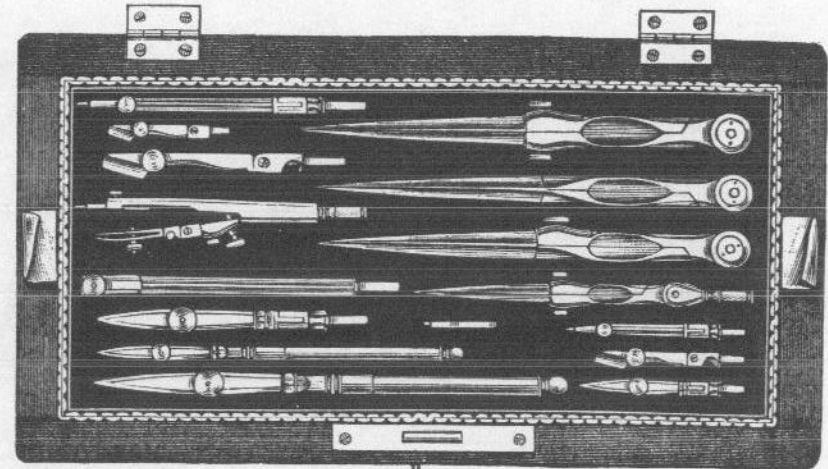

816

- No.  
816. Polished Wood Box, with Well, Lock and Key, containing
- |  |                      |
|--|----------------------|
| Dividers, 5½ ins., with Pen, Pencil, Needle Points and Lengthening Bar, No. 716, |                      |
| “ 3½ ins., with Pen, Pencil and Needle Points,                                   | “ 714,               |
| “ 5 ins., Hair-spring,   | “ 708,               |
| “ 5 “ plain,   | “ 702,               |
| Spring Bow Pen, with Pencil,   | “ 734,               |
| Drawing Pen, 4½ ins.,  | “ 736,               |
| “ “ 5½ “   | “ 738, . . . \$18 00 |
818. Polished Walnut or Rosewood Box, Rounded Corners, with Well, Lock and Key, containing
- |  |                    |
|--|--------------------|
| Dividers, 5½ ins., with Pen, Pencil, Needle Point and Lengthening Bar, No. 716,    |                    |
| “ 4 ins., with Spring and Set Screw, Needle Point, Pencil Point, and 2 Pen Points, | “ 718,             |
| “ plain, 6 ins.,   | “ 704,             |
| “ Hair-spring, 5 ins.,   | “ 708,             |
| “ Steel Spacing,   | “ 720,             |
| Furniture for Beam Compasses,  | “ 752,             |
| Railroad Pen,  | “ 742,             |
| Drawing “  | “ 736,             |
| “ “  | “ 738,             |
| “ “ Red Ink,   | “ 740, . . . 34 00 |



Purchasers should select the Scales, Triangles and Protractors they desire, and have them packed in box.

The Triangles and Protractors which accompany the boxes as generally sold are almost entirely worthless.

*Purchasers may rely upon receiving Cases of Instruments in much better condition than those generally in market.*

Selections of Instruments may be made, and packed at prices for boxes same as Swiss Instruments.

## Mathematical Instruments of Brass, FOR SCHOOLS.

No.	_____	
880.	Rosewood Box, containing	
	Dividers, $4\frac{1}{2}$ inches, Pen, Pencil and Bar,	
	“ $3\frac{1}{2}$ “ plain,	
	Drawing Pen, Ebony Handle,	
	Brass Protractor, . . . . .	\$2 25
882.	Rosewood Box, with Well, Lock and Key, containing	
	Needle Point Dividers, 6 ins., with Pen and Pencil Points, and Lengthening Bar,	
	Plain Dividers, $4\frac{1}{2}$ inches,	
	Needle Point Dividers, $3\frac{1}{2}$ ins., with Pen and Pencil Points,	
	Drawing Pen,	
	Brass Protractor,	
	Horn “ . . . . .	5 00
884.	Rosewood Box, with Well, Lock and Key, containing	
	Needle Point Dividers, 6 ins., with Pen and Pencil Points, and Lengthening Bar,	
	“ “ “ $3\frac{1}{2}$ ins., with Pen and Pencil Points,	
	Plain Dividers, $4\frac{1}{2}$ inches,	
	Spring Bow Pen, with Needle Point,	
	Drawing Pen,	
	Brass Protractor,	
	Horn “ . . . . .	6 00
816.	Same as No. 814, with addition of Proportional Compasses, . . . . .	8 00
818.	German Silver Mounted, Polished Rosewood Box, with Well, Lock and Key, containing	
	Needle Point Dividers, $6\frac{1}{2}$ ins., with Pen and Pencil Points, and Lengthening Bar,	
	“ “ “ 4 ins., with Pen and Pencil Points,	
	Plain Dividers, $4\frac{1}{2}$ inches,	
	Spring Bow Pen,	
	$6\frac{1}{2}$ inch Proportional Dividers,	
	Furniture for Beam Compasses,	
	Ivory Handle Drawing Pen,	
	Horn Protractor,	
	2 Triangles,	
	1 Curve, . . . . .	22 00

This makes the most complete and convenient case of Brass Instruments; the quality is somewhat better than usual

## PROTRACTORS.

### HORN, BRASS, GERMAN SILVER.

No.	Material	Shape	Size	Graduation	Price
1000.	Horn	Semi-circular	5 inches	half degrees	\$ 25
"	"	"	6 "	"	30
"	"	"	8 "	"	80
1001.	Brass	"	4 "	half degrees	35
"	"	"	5 "	"	55
"	"	"	6 "	"	65
1002.	German Silver	Semi-circular	5 inches	half degrees	85
"	"	"	6 "	"	1 00
"	"	"	7 "	"	1 15
1002.	Swiss, German Silver	extra make:			
		Semi-circle, whole degrees	4 inches	centre outer edge	1 50
		"	half " 5 "	" " "	2 00
		"	" 5 "	inner "	2 50
		"	" 6 "	outer "	3 00
		"	" 6 "	inner "	3 00
		"	quarter " 6 "	outer "	3 25
		"	" 6 "	inner "	4 00

### PAPER PROTRACTORS.

Printed from Plates graduated on our Engines.

1004.	Whole Circle	13 inches	half degrees	Drawing Paper	\$ 30
"	"	13 "	"	Bristol Board	40
	Half	5 "	"	"	25
	Full	5 "	"	Drawing Paper	35

## T SQUARES.

These are made or corrected by ourselves. Any size made to order.

1010.	Pearwood	Fixed Head	Blade 18 inches		\$ 60
"	"	"	" 24 "		75
"	"	"	" 36 "		1 25
1011.	"	Swivel	" 18 "		1 25
"	"	"	" 24 "		1 50
"	"	"	" 36 "		2 50
"	"	"	" 48 "		4 00
1012.	Walnut	Rubber Blade	Fixed Head, Blade 20 inches		1 25
"	"	"	" " 36 "		3 00
1013.	"	"	Swivel " 20 "		2 50
"	"	"	" " 30 "		3 50
"	"	"	" " 36 "		4 25

## SCALES.

### TRIANGULAR BOXWOOD SCALES.

No.	Length	Graduation	Price
1020.	24 inches long	graduated 10, 20, 30, 40, 50, 60 to inch	\$5 00
"	12 "	do. do. do. "	2 00
"	8 "	do. do. do. "	1 75
"	6 "	do. do. do. "	1 50
1021.	24 "	1/16, 3/32, 1/8, 1/4, 3/8, 1/2, 3/4, 1, 1 1/2, 3	5 00
"	12 "	do. do. do. do.	2 00
"	8 "	do. do. do. do.	1 75
"	6 "	do. do. do. do.	1 50

### IVORY AND BOXWOOD FLAT CHAIN SCALES.

1023.	Ivory	12 inches long	graduation, 20 and 50	\$3 00
"	"	12 "	" 30 and 40	3 00
"	"	12 "	" 60 and 100	3 25
1024.	Boxwood	12 "	" 20 and 50	1 25
"	"	12 "	" 30 and 40	1 25
"	"	12 "	" 10 and 16	1 25
"	"	12 "	" 12 and 16	1 25

### PLOTTING SCALES AND PROTRACTORS.

1030.	Ivory	6 inches	Plotting Scale, School quality	\$ 75
"	"	6 "	" and Protractor, School quality	1 50
"	"	6 "	one side 1/2 to 1 inch, other side 30 to 60 inches	3 00
"	"	6 "	same graduation, finer quality	4 50
"	"	6 "	same graduation, with Scale of latitude, sin. tan., hours, longitude, seconds and secants	6 00

### PAPER SCALES—on Card Board.

1031.	12 inches long	inches and tenths, and feet and hundredths	\$ 10
"	12 "	twentieths and fortieths	10
"	12 "	inches and sevenths, and inches and forty-eighths	10
"	19 "	in sets of six, with different Scales, for Architects and Engineers, per set	1 00



## TRIANGLES.

No.		
1032.	Hard Rubber Triangles, angles 30, 60 and 90 degrees.	
	Perpendiculars, 3, 4 or 5 inches long, each,	\$ 25
	“ 6 or 7 “ “ “	35
	“ 8 or 9 “ “ “	55
	“ 10 or 11 “ “ “	65
	“ 12 or 13 “ “ “	95
	“ 14 or 15 “ “ “	1 25
	“ 16 or 17 “ “ “	1 75
	“ 8 or 20 “ “ “	2 00
1033.	Hard Rubber Triangles, angles 45, 45 and 90 degrees.	
	Perpendiculars, 3 or 4 inches long, each,	30
	“ 5 or 6 “ “ “	40
	“ 7 or 8 “ “ “	60
	“ 9 or 10 “ “ “	85
	“ 11 or 12 “ “ “	1 25
	“ 13 or 14 “ “ “	1 50
1034.	Whitewood Triangles, solid, 30, 60 and 90 degrees.	
	Perpendiculars, 5 and 7 inches long, each,	10
	“ 8 and 9 “ “ “	15
	“ 11 and 12 “ “ “	20
1035.	Whitewood Triangles, solid, 45, 45, and 90 degrees.	
	Perpendiculars, 3 and 6 inches long, each,	15
	“ 7 and 8 “ “ “	20
1037.	German Silver Triangles, 30, 60 and 90 degrees, Perp. 6 to 7 ins.,	2 50
	“ “ “ “ “ “ “ 9 to 10 “	4 00
	“ “ “ 45, 45 and 45 “ “ 4 to 5 “	2 25
	“ “ “ “ “ “ “ 6 to 7 “	3 50
	“ “ “ “ “ “ “ 8 to 10 “	5 00
1038.	Steel Triangles, 30, 60 and 90 degrees, 6 and 10 ins. Perp.,	4 50
	“ “ “ “ “ 8½ and 6 “	3 50
	“ “ 45, 45 and 90 “ 8 in. Perp.,	4 50
	“ “ “ “ “ 5 “	3 50

## STRAIGHT EDGES.

### HARD RUBBER STRAIGHT EDGES.

No.		
1040.	24 inches long,	\$1 25
	36 “ “	2 10
	48 “ “	2 75

### BEVELLED STEEL STRAIGHT EDGES.

1041.	12 inches long, 1½ inches wide, $\frac{3}{16}$ thick, \$1 25 . Nickel plated, \$1 50	
	18 “ “ 1½ “ “ “ “ 1 50 . “ “ 1 75	
	24 “ “ 2 “ “ “ “ 2 75 . “ “ 3 00	
	36 “ “ 3 “ “ $\frac{1}{4}$ “ “ 4 50 . “ “ 4 75	
	48 “ “ 3 “ “ $\frac{1}{4}$ “ “ 6 00 . “ “ 6 25	

### THIN STEEL STRAIGHT EDGES.

1042.	15 inches long, 1½ inches wide, $\frac{1}{20}$ thick, \$1 25 . Nickel plated, \$1 50	
	18 “ “ 1½ “ “ “ “ 1 75 . “ “ 2 00	
	24 “ “ 1½ “ “ $\frac{1}{8}$ “ “ 2 25 . “ “ 2 50	
	36 “ “ 2 “ “ $\frac{1}{8}$ “ “ 4 50 . “ “ 4 75	
	48 “ “ 2½ “ “ $\frac{1}{4}$ “ “ 7 50 . “ “ 4 75	
	60 “ “ 2½ “ “ $\frac{1}{2}$ “ “ 10 00 . “ “ 10 25	

## Railroad Curves and Cross Section Triangles.

1050.	Railroad Curve Protractor, of Horn. 8 ins. diameter, 23 Curves, of from $\frac{1}{2}$ degree to 8 degrees, radius of 400 feet,	\$2 00
1051.		
1052.		
1053.		
1054.		
1055.		
1056.		
1057.	Cross Section Triangles, Hard Rubber, 7 in set, for Earth Slopes,	4 25
	Single one,	75
1058.	Batter Slopes, Hard Rubber, $\frac{1}{4}$ , $\frac{1}{2}$ , $\frac{3}{4}$ , $1$ , $1\frac{1}{2}$ , set,	2 00
	Single one,	75

## CURVES.

No.					
1060.	Whitewood Irregular Curves, various patterns, each, Small,	.	25	cts	
			Large,	50	"
1061.	Hard Rubber " " " " " " Small,	.	50	"	
			Large,	80	"

Sample Sheet of Curves mailed on application.

## POCKET COMPASSES.

1070.	Brass, form of watch, $1\frac{1}{2}$ ins. diameter, stop, agate and hunting case,	\$2	50
1071.	Charm Compass, $\frac{1}{2}$ in. diameter,	.	50
1072.	Mahogany Pocket Compass, stop, and cover on hinge,	1	50
1073.	Fine London Pocket Compasses, porcelain dial, agate centre, watch form,	1 inch,	6 00
		$1\frac{1}{2}$ "	8 00

These are best imported Pocket Compasses we can obtain.

1074.	Night Pocket Compasses, 2 ins., can be illuminated from below,	9	00
1075.	Geological Compass, pendulum to give angle of inclination,	6	00
1076.	Dipping Needle, used for tracing on, &c., Morocco case,	12 to 15	00

## FIELD AND MARINE OPERA GLASSES.

(11 Lines equal an inch.)

Fine Achromatic Marine or Field Glasses, Morocco bodies, japanned tubes; shade to extend over the Object Glass; hard-sewed leather case, with strap to go over the shoulder, metal tops and rims.			
	21 lines,	.	\$15 00
	24 "	.	16 00
	26 "	.	17 00

Fine Achromatic Marine or Field Glasses, Morocco bodies, japanned tubes, shades to the Object Glasses; hard leather cases, with strap to go over the shoulder, and having 3 powers—Theatre, Field and Marine.			
	24 lines,	.	38 50

Fine Achromatic Field Glasses, Morocco bodies, japanned tubes, having three powers, <i>Theatre, Field and Marine</i> , the marine power being the highest, and having a power as high as the large size Marine Opera Glasses. A very convenient and powerful Opera Glass, equally adapted for use at an opera or for tourists. It is only three inches long, and can be carried very conveniently in the pocket.			
	19 lines,	.	19 00

## ANEROID BAROMETERS.

*The imported supply of any one size and kind of Aneroid Barometer is somewhat uncertain. The following are the best selection of those most generally to be obtained. We make our selection with care, test them for accuracy, and remedy any errors or injuries to be found.*

$1\frac{3}{4}$	inches diameter, altitude scale 8,000 feet, raised ring and thermometer,	\$20	00
$1\frac{3}{4}$	" " altitude scale 8,000 feet, raised ring and thermometer, large bar needle on reverse, to detach,	27	50
$2\frac{1}{2}$	" " altitude scale 8,000 feet, compensated,	21	00
$2\frac{1}{2}$	" " altitude scale 8,000 feet, raised ring and thermometer, compensated,	26	00
$2\frac{1}{2}$	" " altitude scale 15,000 feet, compensated,	26	00
$2\frac{1}{2}$	" " altitude scale 20,000 feet, compensated,	28	50
8	" " SURVEYING BAROMETER, altitude scale 15,000 feet, brass case, engraved silver dial, rack and vernier scale, reading 5 feet, compensated, in leather sling case,	44	00
5	" " altitude scale 5,000 feet, brass case, silvered metal dial, raised ring, rack and vernier scale, reading to 1 foot, and magnifying lens, leather case,	52	00
	Same as above, but altitude scale 15,000 feet,	72	00
5	" " MINING BAROMETER, altitude 2,000 feet below and 4,000 feet above sea level, with rack and vernier scale, reading single feet, leather sling case,	52	00
	Leather Cases, for $2\frac{1}{2}$ inch diameter Barometers, best quality,	3	50



# Engineers' Stationery and Supplies,

FOR FIELD AND OFFICE USE.

## WINDSOR AND NEWTON'S WATER COLORS.

Burnt Carmine, . . . . .	Carmine, . . . . .
Cadmium Yellow, . . . . .	Gallstone, . . . . .
Cadmium Orange, . . . . .	Pure Scarlet, . . . . .

Aureoline, . . . . .	Lemon Yellow, . . . . .
French Blue, . . . . .	Pink Madder, . . . . .
Green Oxide of Chrome, . . . . .	Rose Madder, . . . . .
Intense Blue, . . . . .	

Whole Cakes, \$1.15.

Half Cakes, 60 cents.

Cobalt Blue, . . . . .	Violet Carmine, . . . . .
Orange Vermilion, . . . . .	

Whole Cakes, 85 cents.

Half Cakes, 45 cents

Brown Madder, . . . . .	Roman Sepia, . . . . .
Crimson Lake, . . . . .	Ruben's Madder, . . . . .
Indian Yellow, . . . . .	Scarlet Lake, . . . . .
Mars Yellow, . . . . .	Scarlet Vermilion, . . . . .
Neutral Orange, . . . . .	Sepia, . . . . .
Purple Lake, . . . . .	Warm Sepia, . . . . .

Whole Cakes, 60 cents.

Half Cakes, 30 cents.

Antwerp Blue, . . . . .	Ivory Black, . . . . .
Chinese White, . . . . .	King's Yellow, . . . . .
Bistre, . . . . .	Lamp Black, . . . . .
Blue Black, . . . . .	Naples Yellow, . . . . .
British Ink, . . . . .	Neutral Tint, . . . . .
Brown Ochre, . . . . .	Olive Green, . . . . .
Brown Pink, . . . . .	Orange Chrome, . . . . .
Burnt Roman Ochre, . . . . .	Payne's Grey, . . . . .
Burnt Sienna, . . . . .	Prussian Blue, . . . . .
Burnt Umber, . . . . .	Prussian Green, . . . . .
Chrome Yellow, . . . . .	Raw Sienna, . . . . .
Deep Chrome, . . . . .	Raw Umber, . . . . .
Emerald Green, . . . . .	Red Lead, . . . . .
Flake White, . . . . .	Roman Ochre, . . . . .
Gamboge, . . . . .	Sap Green, . . . . .
Hooker's Green, No. 1, . . . . .	Terra Vert, . . . . .
" " " 2, . . . . .	Vandyke Brown, . . . . .
Indigo, . . . . .	Vermilion, . . . . .
Indian Red, . . . . .	Yellow Lake, . . . . .
Italian Pink, . . . . .	Yellow Ochre, . . . . .

Whole Cakes, 30 cents.

Half Cakes, 15 cents.

## WATER COLOR LIQUIDS.

Carmine, . . . . .	Indian Ink, . . . . .
Chinese White, . . . . .	Gold " . . . . .
Oxgall, . . . . .	Indelible Brown Ink, . . . . .

Bottles, 50 cents each.

## INDIA INK.

The supply of Indian and Japanese ink is uncertain. We would advise Engineers, desiring good qualities, to name an approximate price and allow us to select.

Small Stick, oval, lion's head, . . . . .	per stick, \$	50
" " square, gilt, . . . . .		25
Good quality, . . . . .		75
Very good quality, . . . . .		2 00
Superior qualities, ranging from . . . . .	8 00 to	5 00
Extra " " " " . . . . .	5 00 to	8 00
Liquid Ink, in bottles, . . . . .		50

## JAPANESE INK.

The best adapted for drawings that have to be washed.

Best, small cake, . . . . .	\$1 25	Large, . . . . .	3 50
-----------------------------	--------	------------------	------

## COLORED PENCILS.

Red, Blue, Green, Yellow or Black, . . . . .	each,	12
Red Chalk Pencils, for marking stakes, . . . . .	per doz.,	1 25
" in lump, " " " " . . . . .	per lb.,	40

## PAINT SLABS AND SAUCERS.

China Cups, 1 inch diameter, . . . . .	each,	5
" " 2 " " " " . . . . .	"	10
" " 3 " " " " . . . . .	"	20
Cabinet Nests of 6, 2 1/4 inch diameter, . . . . .	per nest,	75
" " 6, 2 3/4 " " " " . . . . .	"	1 25
Slant Tiles, 3 divisions, . . . . .	each,	30
" " 6 " " " " . . . . .	"	70
" " 4 slant and 1 flat division, . . . . .	"	50

Tiles for India Ink, 1 long slant and 3 round wells.

Size, 1 1/2 by 2 1/8 inches, . . . . .	each,	20
" 2 3/8 by 4 " " " " . . . . .	"	40

## BRUSHES.

Usual Camel's Hair Brushes, in quills, assorted, . . . . .	per doz.,	60
Small to medium, . . . . .	"	75
Medium to large, . . . . .	"	
Fine Camel's Hair Brushes, with tin ferules and wood handles, . . . . .		
for fine water color painting, assorted, . . . . .		
Small to medium, . . . . .	"	1 25
Medium to large, . . . . .	"	1 75
Camel's Hair Brushes, for washing, best quality, polished wood handles, assorted, . . . . .	"	3 00
Small to medium, . . . . .	"	4 00
Medium to large, . . . . .	"	
Red Sable Brushes, in quills, assorted, . . . . .	each,	20 to 30
Small to medium, . . . . .	"	35 to 75
Medium to large, . . . . .	"	
Red Sable Brushes, with albatra ferules and wood handles, . . . . .		
assorted, . . . . .		
Small to medium, . . . . .	"	30 to 80
Medium to large, . . . . .	"	1 00 to 2 50

**INDIA RUBBER, MAPPING PENS, &c.**

Indicate particularly kind of rubber desired.

White, prepared,	per piece,	\$ 6
Pure Gum,	"	15
Erasing Rubber—Ink and Pencil,	"	25
Mouth Gluc,	"	5
Erasing Knife,	each,	50
Gillot's Mapping Pens. 12 on card, with handle,	per card,	60
" Lithographic Crow Quill Pen, 12 on card, with handle,	"	60
" No. 290,		5 00
" " 291,		6 00

**LEAD PENCILS.**

Any number less than a dozen charged as single ones.

A. W. Faber's superior Siberian Lead Pencils, B. HB. & H.,	each,	15
	Per dozen,	1 25
" Hexagonal Gilt, Nos. 1, 2, 3, 4,	each,	7
	Per dozen,	75
" black, round and gilt, Nos. 1, 2, 3, 4,	each,	7
	Per dozen,	75
" " " " Union, Nos. 1, 2, 3, 4,	each,	7
	Per dozen,	60
" " " " Star, Nos. 1, 2, 3, 4,	each,	5
	Per dozen,	50
Small Pencils for the Dividers,	each,	5

**WHATMAN'S DRAWING PAPERS.**

	Per Quire.	Per Quire.
13 × 17 inch Cap, Selected Best,	\$ 80.	Retre or 2d Quality. \$ 70
15 × 20 " Demy,	1 00.	" " 85
17 × 22 " Medium,	1 50.	" " 1 25
19 × 24 " Royal,	1 85.	" " 1 60
19 × 27 " Super-royal,	2 50.	" " 2 00
23 × 28 " Elephant,	3 50.	" " 3 00
22 × 30 " Imperial,	3 50.	" " 3 00
26 × 34 " Atlas,	4 50.	" " 4 00
27 × 40 " Double Elephant,	5 50.	" " 5 00
31 × 53 " Antiquarian,	30 00.	" " 18 00

Hot pressed has smooth surface; cold pressed has rough surface.

**TOWNSHIP PLOTTING PAPER.**

Township Plotting Paper, Rulings 6 × 6 blocks, blocks 1 inch square,	per 100 sheets,	\$2.00
Township Plotting Paper, Rulings 12 × 12 blocks, 2 inches square, per 100 sheets,		2 50

<b>Bond Paper, for tracing, very tough,</b>					
	16 × 21	16 × 24	19 × 24	19 × 30 inches.	
per 100 sheets,	\$3 25	3 75	4 00	5 00	
English Parchment,	16 × 20	18 × 20	18 × 22	18 × 24	20 × 24 inches.
per dozen,	\$5 25	6 00	7 00	1 25	7 50

Gelatine or Glass Paper,	13 × 19	17 × 21 inches.
per dozen,	\$3 50	4 00

**Transfer Paper, blue, red and black, 18½ × 23 in., Royal, per doz., \$2 50****White Mounting Board, 22 × 28 in., according to thickness, per sheet, 15 to 25****BUFF TINT DRAWING PAPER.***Best English, in Rolls of 40 to 60 Pounds.*

Best English Detail Paper—Extra tough, buff color, thin, medium, thick, in rolls of 40 to 60 pounds.			
40 inches wide, medium thickness,	per pound, \$	50.	per yard, \$ 25
54 " " " " " " " "	"	50.	" 40
Best American Detail Paper.—Extra tough, buff color, thin, medium, thick, in rolls of 70 to 100 pounds.			
36 inches wide, thick,	per pound, \$	14.	per yard, \$ 12
42 " " " " " " " "	"	14.	" 16
48 " " " " " " " "	"	14.	" 18
54 " " " " " " " "	"	14.	" 20

Full rolls only sold by the pound at the above rates.

**TRACING OR VELLUM CLOTH.**

In Rolls of 24 yards, both sides glazed, or face glazed and back dull, suitable for pencil marks.

Imperial, 18 inches wide,	per roll,	\$5 00.	per yard, \$ 25
" 30 " " " " " " "	"	6 90.	" 40
" 36 " " " " " " "	"	7 50.	" 45
" 42 " " " " " " "	"	10 50.	" 60
Sagar's Patent, 18 inches wide,	"	4 10.	" 25
" " 30 " " " " " " "	"	7 40.	" 40
" " 36 " " " " " " "	"	8 00.	" 45
" " 42 " " " " " " "	"	11 00.	" 60

**TRACING PAPER.—Continuous.**

French, Best Vegetable.—54 inches wide, in rolls of 22 yards,	per roll, \$5 00
" Common.—42 inches wide, in rolls of 22 yards,	" 3 50
" Stout.—42 inches wide, in rolls of 22 yards,	" 4 00
German, very Best, very tough and transparent.—54 inches wide, in rolls of 30 yards,	" 8 00
German, not Prepared, for transferring.—54 inches wide, in rolls of 44 yards,	" 6 00
Extra Stout, very tough, suitable for machinists—40 inches wide, in rolls of 20 yards,	" 4 50
German, 58 inches wide, 22 yards,	" 5 00
" 58 " " 33 " " "	" 7 50

**TRACING PAPER.—In Sheets.**

French Vegetable, very tough and transparent.		
13 × 17 inches, Cap, thin,	per quire,	1 20
15 × 20 " Demy, thin,	"	1 50
18 × 24 " Royal, thin and thick,	"	2 50
21 × 27 " Imperial, thin and thick,	"	3 30
27 × 38 " Double Elephant, thin,	"	9 00
French, Common.—20 × 30 inches, medium,	"	1 50
" " 30 × 40 " " "	"	3 00
" " 30 × 40 " thick,	"	3 50
Fine Glazed, very transparent and tough.—30 × 40 inches,	"	4 50
Extra Stout, very tough, suitable for machinists.—30 × 40 inches,	"	4 50



**TRACING PAPER—Continuous.**

French, Best Vegetable.—54 inches wide, in rolls of 22 yards,	per roll, \$5 00
“ Common.—42 inches wide, in rolls of 22 yards,	“ 2 50
German, very Best, very tough and transparent.—54 inches wide, in rolls of 44 yards,	“ 6 00
German, not Prepared, for transferring.—54 inches wide, in rolls of 44 yards,	“ 6 00
Extra Stout, very tough, suitable for machinists.—40 inches wide, in rolls of 20 yards,	“ 3 50
German.—58 inches wide, 22 yards,	“ 5 00
Parchment, very tough.—38 inches wide, 33 yards,	“ 7 50

**DRAWING PAPERS IN CONTINUOUS ROLLS.***Mounted and not mounted.*

Our line of white roll drawing papers has been carefully selected and manufactured. Being made from linen stock, the quality is unsurpassed, and we believe that it will fully meet the wants of all engineering or architectural draughtsmen. Samples of any of the papers will be sent on application. The following brief description may aid our customers in selecting a paper suited to their wants:

The Constantia, or 311 Paper, is of good quality, medium in weight, with a slight grain and tint.

The I. X. L., or 302 Paper, has a smooth surface on one side. The reverse is slightly roughened. The smooth side is especially suitable for drawings intended to be photographed. The rough for fine office drawings.

The Acme, or Paragon, for general drafting, are unsurpassed. The color is white. The grain similar to the well-known Egg Shell, but much more regular and uniform. Are extremely strong, and stand handling and erasing perfectly.

The Egg Shell Paper, having a rough, grainy surface, works up nicely in water-colors.

The Leonine is an extra stout, tinted paper, suitable for shop drawings requiring rough handling.

**WHITE DRAWING PAPER—Mounted on Muslin.**

No.		In rolls of 10 and 20 yards.	
300.	Eggshell, Medium, 36 inches wide,		\$8 50
“	“ “ 42 “ “		9 00
“	“ “ 54 “ “		12 00
“	“ “ 58 “ “		12 50
300.	Paragon and Acme, Medium, 36 inches wide,		8 50
“	“ “ “ 42 “ “		9 00
“	“ “ “ 54 “ “		12 00
“	“ “ “ 58 “ “		12 50
300½.	Eggshell, Thin, 54 inches wide,		11 50
“	“ “ 58 “ “		12 00
301.	“ Heavy, 54 “ “		13 00
“	“ “ 58 “ “		14 00
302.	Smooth, 54 “ “		12 50
“	“ “ 58 “ “		13 50
303.	Rough, 58 “ “		13 00
304.	Medium, 58 “ “		13 00
305.	Heavy, 54 “ “		13 50
306.	Medium, 54 “ “		12 00
307.	Heavy, Smooth, 42 “ “		11 00
“	“ “ 54 “ “		14 00
308.	Medium, 42 “ “		9 00
309.	Thin, 36 “ “		8 00
310.	Medium, 36 “ “		8 00
“	“ “ 42 “ “		8 50
311.	“ “ 36 “ “		8 00
312.	Leonine, 62 “ “		18 50

**CONTINUOUS DRAWING PAPER—WHITE.**

In rolls of 30 to 40 lbs.

No.			Per lb,	10 yd. rolls,	Per yd.
300.	White Eggshell Drawing Paper, Medium, 42 in. wide,	\$0 45	\$3 00	\$0 35	
“	“ “ “ “ 58 “ “	45	4 00	45	
300.	White, Acme or Paragon Draw- } .. 42 “	45	3 00	35	
“	“ “ “ “ ing Paper, } .. 58 “	45	4 00	45	
300½.	White Eggshell Drawing Paper, Thin, 58 “	45	3 75	40	
301.	“ “ “ “ Heavy, 58 “	45	4 50	50	
302.	Smooth Drawing Paper, 58 inches wide,	45	4 50	50	
303.	Rough “ “ 58 “ “	45	4 50	50	
304.	Medium “ “ 58 “ “	45	4 50	50	
305.	Heavy “ “ 54 “ “	55	6 00	70	
306.	Medium “ “ 54 “ “	55	4 50	50	
307.	Heavy Smooth “ “ 42 “ “	45	4 00	45	
“	“ “ “ “ 54 “ “	45	5 00	55	
308.	Medium “ “ 42 “ “	45	4 00	45	
309.	Thin “ “ 36 “ “	45	3 00	35	
310.	Medium “ “ 36 “ “	35	2 50	25	
311.	“ “ 42 “ “	35	2 50	70	
312.	Leonine “ “ 62 “ “	45	4 50	50	

**ROLL DRAWING PAPERS FOR SENSITIZING.**

42 inches wide,	per roll of 50 yards,	\$8 00
54 “ “	“ “	10 50
Steinbach's, 53 inches wide, very superior, light,	per yard,	35
“ “ “ “ heavy,	“ “	50

**Architects' Manila Sketching Paper, 31 × 50,** per quire, 7 50

This paper is an entirely new article, needs no stretching, will not buckle, and is especially recommended.

**THE BLUE PROCESS OF COPYING TRACINGS.**

Special attention has recently been directed to this easy process of copying tracings, and its great value to all Engineers, Architects and Mechanical Draughtsmen fully recognized.

The instructions in using are—

1. Provide a flat board as large as the tracing which is to be copied.
2. Lay on this board two or three thicknesses of common blanket, or its equivalent, to give a slightly yielding backing for the paper.
3. Lay on the blanket the prepared paper, with the sensitive side uppermost.
4. Lay on this paper the tracing, smoothing it out as perfectly as possible, so as to insure a perfect contact with the paper.
5. Lay on the tracing a plate of clear glass, which should be heavy enough to press the tracing close down upon the paper. Ordinary plate glass, of three-eighths thickness, is quite sufficient.
6. Expose the whole to a clear sunlight, by pushing it out on a shelf from a window, or in any other convenient way, from four to six minutes [in winter six to ten minutes]. If a clear sky only can be had, the exposure must be continued from twenty to thirty minutes; and, under a cloudy sky, from sixty to ninety minutes may be needed, the shade depending on the time.
7. Remove the prepared paper, and wash it freely for one or two minutes in clear water, and hang it by one corner to dry.

### PREPARED SENSITIVE PAPERS

are packed in tubes to keep from light, one dozen sheets in each tube, and are always ready for immediate use.

Demy, 16 × 21,	price, per dozen, \$0 85
Medium, 18 × 23,	1 25
Royal, 19 × 24,	1 50
Super Royal, 20 × 28,	1 65
Doubl. Medium, 18 × 36,	2 25
Imperial, 23 × 31,	2 00
Double Elephant, 27 × 40,	3 50
Antiquarian, 31 × 53,	6 50
Sensitized Solar Printing Paper, 42 inches wide, in continuous rolls of	
10, 20 or 50 yards,	per yard, 40
Photo-Solution,	per bottle, 4 40

### ROLL PAPERS FOR SENSITIZING.

In continuous rolls of 55 yards in length.

42 inch,	per roll, \$8 50
	per yard, 20
60 inches wide,	per roll, 12 00
	per yard, 30
Roll 55 yards, 36 inches,	7 00
" 55 " 42 "	8 00
" 55 " 54 "	10 50

The above papers absorb the fluid more rapidly and enduringly, and give better prints than any others.

### DOUBLE-LENGTH PROFILE PAPER.

Plate A.—Rulings 42 inches long by 15 inches wide, Horizontal Divisions, four to the inch; Vertical Divisions, twenty to the inch, and having every tenth horizontal division line, and every fiftieth vertical division line, heavier than the others. Price, per sheet, 40 cts., per quire, 8 50

Plate A.—Rulings 42 inches long by 6½ inches wide, Horizontal Divisions, four to the inch; Vertical Divisions, twenty to the inch, and having every tenth horizontal division line, and every fiftieth vertical division line, heavier than the others. Price, per sheet, 30 cts., per quire, 6 50

Plate B.—Rulings 42 inches long by 13 inches wide, Horizontal Divisions, four to the inch; Vertical Divisions, thirty to the inch, and having every fourth horizontal division line, and every twenty-fifth vertical division line, heavier than the others. Price, per sheet, 40 cts., per quire, 8 50

Plate B.—Rulings 42 inches long by 6½ inches wide, Horizontal Divisions, four to the inch; Vertical Divisions, thirty to the inch, and having every fourth horizontal division line, and every twenty-fifth vertical division line, heavier than the others. Price, per sheet, 30 cts., per quire, 6 50

Plate C.—Horizontal Divisions, five to the inch; Vertical Divisions, twenty-five to the inch, and having every fifth horizontal division line, and every twenty-fifth vertical division line, heavier than the others. Price, per sheet, 40 cts., per quire, 8 50

### CONTINUOUS OR ROLL PROFILE PAPER.

Plate A.—Rulings 22 inches wide, Horizontal Divisions, four to the inch; Vertical Divisions, twenty to the inch, and having every tenth horizontal division line, and every fiftieth vertical division line, heavier than the others, Price, per yard, \$ 30

Plate B.—Rulings 22 inches wide, Horizontal Divisions, four to the inch; Vertical Divisions, thirty to the inch, and having every fourth horizontal division line, and every twenty-fifth vertical division line, heavier than the others, Price, per yard, 30

Plate B.—Rulings 9 inches wide, Horizontal Divisions, four to the inch; Vertical Divisions, thirty to the inch, and having every fourth horizontal division line, and every twenty-fifth vertical division line, heavier than the others, Price, per yard, 20

Plate C.—Horizontal Divisions, five to the inch; Vertical Divisions, twenty-five to the inch, and having every fifth horizontal division line, and every twenty-fifth vertical division line, heavier than the others; in Sheets, Rulings 42 × 15 inches, Price, per yard, 30

Profile Paper, Metric—In Continuous Roll, Rulings 50 centimetres wide, in millimetres, with each fifth millimeter, each centimeter, and each decimetre proportionally heavier than the millimeters, Price, per yard, 30

### MUSLIN BACKED ROLL PROFILE PAPER.

Muslin Backed Roll Profile Paper, of either Plate A or B, 22 inches wide, in rolls of 20 yards, per yard, 75

Muslin Backed Roll Profile Paper, Plate B, 9 inches wide, in roll of 20 yards, per yard, 50

Plate B corresponds to that in sheets known as Brown's Profile Paper.

### CROSS SECTION PAPERS.

Topographical Paper, 14 × 17 inches, ruled 400 feet to the inch, Per sheet, 12 cts., per quire, 1 75

Trautwine's Cross Section and Diagram, 10 feet to inch, for embankments of 14 and 24 feet, roadway, and for excavations of 18 and 28 feet, rulings 19¼ × 12 inches, Per sheet, 25 cts., per quire, 5 00

Cross Section Papers, rulings 22 × 16 inches, 8 feet to inch, Per sheet, 25 cts., per quire, 5 00

Cross Section Papers, rulings 22 × 16 inches, 10 feet to inch, Per sheet, 25 cts., per quire, 5 00

Cross Section Papers, rulings 22 × 16 inches, 10 feet to inch, every fifth line heavy, Per sheet, 25 cts., per quire, 5 00

Cross Section Papers, rulings 22 × 16 inches, 16 feet to inch, Per sheet, 25 cts., per quire, 5 00

All the Profile and Cross Section Papers can be furnished, printed with red or green lines.



# FIELD BOOKS.

*We have lately increased our line of Field Stationery, by selection from our own and other makers, and Engineers will find it the most complete from which to select.*

- A.** YOUNG'S PROFILE FIELD BOOK,  $7\frac{1}{2} \times 4\frac{1}{2}$ ; left hand page full rulings, 7 columns, 26 lines; right hand page ruled as profile paper, perpendicular 4 to the inch, horizontal 20 to the inch. . per doz., \$9 00
- B.** YOUNG'S PROFILE FIELD BOOK; same as Profile Field Book A, excepting the perpendicular columns, which are  $2\frac{1}{2}$  to the inch, . . . . . per doz., 9 00
- These Books will be found exceedingly convenient. The rulings on right hand page do not interfere with taking the usual notes, whilst on surveys the profile of the work can be dotted down conveniently as work progresses; and on construction the profile accompanies the notes of lines, cuts, etc., etc., so the monthly amounts and variations of work, and other necessary memoranda, can be carried in most convenient manner.
- Form A is preferable on surveys, allowing room for intermediates.  
Form B is preferable on construction.
- C.** TRANSIT BOOK,  $7 \times 4$ ; Drawing Paper; left hand page 6 columns, right hand vertical rulings, 8 to inch, . . . . . per doz., \$6 00
- D.** TRANSIT BOOK,  $6\frac{1}{2} \times 4$ ; Extra Smooth Paper; same rulings as C, . . . . . per doz., 4 50
- E.** LEVEL BOOK,  $7 \times 4$ ; Drawing Paper; left hand 7 columns, right plain rulings, . . . . . per doz., 6 00
- F.** LEVEL BOOK,  $6\frac{1}{2} \times 4$ ; Extra Smooth; same rulings as E, per doz., 4 50

- L.** TRANSIT BOOK, Smooth,  $7\frac{1}{2} \times 5$ ; left page 6 columns, right perpendicular (square), 4 to the inch, . . . . . per doz., \$7 00
- M.** TRANSIT BOOK, Smooth,  $7\frac{1}{2} \times 4\frac{3}{4}$ ; left hand 6 columns, right hand perpendicular, 8 to the inch, . . . . . per doz., 7 00
- N.** TRANSIT BOOK, Smooth,  $7\frac{1}{2} \times 4\frac{3}{4}$ ; left hand page 7 columns, right hand rulings (square), 4 to the inch, . . . . . per doz., 7 00
- O.** TRANSIT BOOK, Smooth,  $6\frac{3}{4} \times 4\frac{1}{2}$ ; left hand 6 columns, right perpendicular, 4 to the inch, square, . . . . . per doz., 6 00
- P.** TRANSIT BOOK, Smooth,  $7\frac{1}{2} \times 4\frac{3}{4}$ ; left hand page 7 columns, right hand page cross-section rulings (squares), 4 to the inch, every fifth horizontal and every second perpendicular heavy, . . . . . per doz. 9 00
- Q.** TRANSIT BOOK, Smooth,  $7\frac{1}{2} \times 4\frac{3}{4}$ ; right hand page 7 columns; left hand has two wide columns, giving more space for notes—remainder vertical rulings (squares), 4 to the inch, . . . . . per doz., 7 00
- R.** LEVEL BOOK, Smooth,  $6\frac{3}{4} \times 4\frac{1}{4}$ ; 6 vertical columns of each page, . . . . . per doz.. 5 00
- S.** LEVEL BOOK, Smooth,  $7\frac{1}{2} \times 4\frac{3}{4}$ ; rulings same as R, except 7 vertical columns, . . . . . per doz., 7 00
- T.** CROSS SECTION, Smooth,  $7\frac{1}{2} \times 4\frac{3}{4}$ ; two columns left side, remainder squares, 4 to the inch, . . . . . per doz., 7 00
- V.** CROSS SECTION, Smooth,  $8 \times 7$ ; squares blue, 5 to the inch; every fifth vertical and horizontal line red (inch squares), per doz., 12 00
- Z.** METRIC CROSS SECTION,  $8 \times 7$ , . . . . . per doz., 12 00

*Cross Section Paper, of any desired rulings, bound into books of any desired size.*

PROFILE PAPERS OF ALL PATTERNS.

### LYONS' TABLES.

**Lyons' Tables.** A set of Tables for finding at a glance the true cubical contents of Excavation and Embankments for all Bases, and for every variety of Ground and Side Slopes. By M. E. LYONS, C. E.

Sheet No. 1.	General Table for all Bases and all Slopes.	
" 2.	For Side Hill Cuts and Fills.	
" 3.	Base 12 feet Slopes,	1½ to 1
" 4.	" 14 "	1½ to 1
" 5.	" 15 "	1¼ to 1
" 6.	" 15 "	1 to 1
" 7.	" 15 "	1½ to 1
" 8.	" 16 "	1¼ to 1
" 9.	" 16 "	1 to 1
" 10.	" 18 "	1 to 1
" 11.	" 18 "	1¼ to 1
" 12.	" 18 "	1 to 1
" 13.	" 18 "	1½ to 1
" 14.	" 20 "	1½ to 1
" 15.	" 24 "	1 to 1
" 16.	" 24 "	1½ to 1
" 17.	" 25 "	1½ to 1
" 18.	" 26 "	1½ to 1
" 19.	" 28 "	1 to 1
" 20.	" 30 "	1 to 1
" 21.	" 30 "	1½ to 1
" 22.	" 30 "	1½ to 1
" 23.	" 32 "	1 to 1
" 24.	" 32 "	1½ to 1

The Tables are printed in clear, bold type, on tinted paper, sheets 25 × 16 inches. They may be used by candle light without injuring the eyesight. Each sheet is complete in itself, and embraces all that is wanted in connection with the Base or Slope designated, whether on level or side-hill cross section.

Per sheet, 25 cents; bound in one volume, \$8 50.

### BOUND PROFILE BOOKS.

These books are for field or office purposes, being printed on both sides, of a tough, thick paper, and bound in flexible covers convenient for the pocket. Each page will contain a profile of three thousand feet in length, so that each folio will contain an average section of a road as usually laid out for construction. Railroad and other engineers will find them very useful. Size of book, 9½ by 5½ inches. The rulings correspond to our large profile plates A and B.

Plate A, 25 leaves, imitation Turkey morocco, with elastic band,	\$3 50
" 50 " " " " " " " " " " " "	5 00
" 100 " " " " " " " " " " " "	8 00
" 50 " Turkey morocco, turned edges, with elastic band,	6 00
" 100 " " " " " " " " " " " "	9 00
Plate B, 25 " imitation Turkey morocco, with elastic band,	3 50
" 50 " " " " " " " " " " " "	5 00
" 100 " " " " " " " " " " " "	8 00
" 50 " Turkey morocco, turned edges, with elastic band,	6 00
" 100 " " " " " " " " " " " "	9 00

### PROFILE FIELD BOOK.

Affords the Engineer an Ordinary Field Book, or Transit Book, one page of which can, if desired, be used as a profile. The benefits are, that in Preliminary or Location, the Engineer is enabled to plot his profile as he advances, and on construction he carries in the same book as his notes of curves, &c., a regular profile opposite his other notes, and ready for comparison of both at once. The profile ruling is accurately placed in.

This Book can be used as the ordinary Field or Transit Book.

Price, per dozen, . . \$9.00.

### ALPHABET AND SPECIMEN BOOKS.

Beckers. Letter Book and Ornamental Penmanship,	\$4 00
Copley. Draughtsman's Alphabets, Titles, Borders, &c.,	3 00
Keuffel & Essers. Draughtsman's Alphabets, Borders, Titles, &c.,	2 00

*Copley's and Keuffel & Essers' Books are meritorious works, useful to Engineer, Surveyor and Draughtsman.*



## FIELD BOOKS.

<b>Beans.</b> A Treatise on Railroad Curves and Location of Railroads. Illustrated. 12mo, tuck,	\$1 50
<b>Burt.</b> Key to Solar Compass, and United States Surveyor's Companion. Tuck,	2 50
<b>Byrne.</b> Pocket Book for Railroad and Civil Engineers; containing New, Exact and Concise Methods for Laying Out Railroad Curves, Switches, &c. Illustrated. 18mo. By Oliver Byrne,	1 75
<b>Griswold.</b> Railroad Engineers' Pocket Companion. By W. Griswold. 12mo, tucks,	1 75
<b>Hamilton.</b> Useful Information for Railway Men. Compiled by W. G. Hamilton, Engineer. Third edition, revised and enlarged, 600 pages, pocket form, morocco. New York, 1871,	2 00
<b>Haskoll.</b> Engineer's, Mining, Surveyor's and Contractors' Field Book. By W. Davis Haskoll. London, 1866. 1 vol., 12mo, cloth,	6 00
<b>Haslett.</b> The Mechanics', Machinists', and Engineers' Practical Book of Reference. By C. Haslett. 16mo, tucks,	2 50
<b>Haswell.</b> Engineers' and Mechanics' Pocket Book. By C. H. Haswell. Second edition, revised and enlarged to 663 pages. Tucks,	3 00
<b>Haswell.</b> Mechanics' Tables. By C. H. Haswell,	1 00
<b>Haswell.</b> Mensuration. By C. H. Haswell,	1 25
<b>Henck.</b> Field Book for Railroad Engineers. By J. B. Henck. Tucks,	2 50
<b>Molesworth.</b> Pocket Book of Useful Formulæ, and Memoranda for Civil and Mechanical Engineers. By G. L. Molesworth. 1 vol., 32mo, oblong, morocco, gilt,	2 00
<b>Nystrom.</b> Pocket Book of Mechanics and Engineering. By J. W. Nystrom. 11th edition. Phila., 1872,	3 50
<b>Rumble.</b> Illustrated Engineering Price Book. By T. W. Rumble. Quarto. London, 1865,	1 00
<b>Scribner.</b> Engineers', Contractors' and Surveyors' Pocket Table-Book. By J. M. Scribner. 18mo, tucks,	2 00
<b>Scribner.</b> Mechanic's Companion. By J. M. Scribner. 18mo, tuck,	2 00
<b>Shunk.</b> A Practical Treatise on Railway Curves, and Location, for Young Engineers. By W. F. Shunk,	2 00
<b>Trautwine.</b> The Field Practice of Laying Out Circular Curves for Railroads. By J. C. Trautwine, C. E. 6th edition, revised and enlarged. 12mo, morocco, tucks. Philadelphia, 1869,	2 00
<b>Trautwine.</b> A New Method of Calculating the Cubic Contents of Excavations and Embankments by the Aid of Diagrams. By J. C. Trautwine. 3d edition, revised and enlarged. Philadelphia, 1869,	2 00
<b>Trautwine.</b> The Civil Engineer's Pocket Book. By J. C. Trautwine. 12mo, 648 pages, tuck. Philadelphia, 1872,	5 00

# EASY RULES

FOR THE

## MEASUREMENT OF EARTHWORKS

BY MEANS OF THE  
PRISMOIDAL FORMULA.

Illustrated with numerous Woodcuts, Problems and Examples, and concluded by an Extensive Table for Finding the Solidity in Cubic Yards from Mean Areas.

THE WHOLE

Being adapted for convenient use by Engineers, Surveyors, Contractors, and Others needing Correct Measurements of Earthwork.

By ELLWOOD MORRIS, CIVIL ENGINEER.

Price, . . . \$2.00.

# POCKET BOOK

OF

## MECHANICS AND ENGINEERING,

CONTAINING A MEMORANDUM OF FACTS AND CONNECTION OF  
PRACTICE AND THEORY.

By JOHN W. NYSTROM, C. E.

13th Edition, Revised and Enlarged, with ORIGINAL MATTER.

Price, . . . \$3.50.

# ELEMENTS OF MECHANICS.

ONE OF THE MOST SUCCESSFUL APPLICATIONS OF SCIENCE TO THE  
PRACTICAL QUESTIONS OF THE ENGINEER.

By JOHN W. NYSTROM.

Price, . . . \$4.00.

## INDEX.

## ENGINEERING INSTRUMENTS.

	Page		Page
Additions to Mining Transits, . . . . .	59	Half Length Tripod, . . . . .	59
Adjustments, . . . . .	15	Illumination of Cross Webs, . . . . .	46, 59
" of Burt's Solar Compass, . . . . .	23	Improvements, . . . . .	28
" of Level Instrument, . . . . .	20	Improved Eye Piece, . . . . .	32
" of Surveyor's Compass, . . . . .	22	" Attachment to Tripod, . . . . .	34
" of Transit Instrument, . . . . .	16	" Gradiometer, . . . . .	28
Astronomical Instruments, . . . . .	84	" Slide Protector, . . . . .	33
Arm Protractor, . . . . .	71	" Shifting Tripod, . . . . .	34
Boxing of Instruments, . . . . .	2	" Tangent, . . . . .	33
Burt's Solar Compass, . . . . .	62	" Web Fastener, . . . . .	33
" " " Repairs to, . . . . .	9	" Telescope, . . . . .	34
" " " Adjustment, . . . . .	23	" Verniers, . . . . .	36
Care of Instruments, . . . . .	5	Instruments, Astronomical, . . . . .	84
Centres of Instruments, . . . . .	6	" Care of, . . . . .	5
Chains and Tapes, . . . . .	74-76	" Engineering, . . . . .	10
Chain Tape, . . . . .	75	" Repairs to, . . . . .	8
Chesterman Steel Tapes, . . . . .	75	" Selection, . . . . .	13
" Metallic Tapes, . . . . .	75	Level Instrument, . . . . .	43-45
City Transit, . . . . .	50, 53	" " Adjustment, . . . . .	20
Cleaver Protractor, . . . . .	70	" " Repairs to, . . . . .	9
Coast Survey Pattern Repeating Circle, . . . . .	52	" Rcd, Young's Self-reading, . . . . .	66
Compasses, . . . . .	65	" " Mining Pattern, . . . . .	60
" Adjustment, . . . . .	22	" Hand, . . . . .	67
" Repairs to, . . . . .	9	Light Transit, . . . . .	51
" Pocket, . . . . .	68, 108	Magnetic Needle, . . . . .	5
Cross Web, . . . . .	6	" " Adjustment, . . . . .	26
" Illumination, . . . . .	46, 59	Materials of Instruments, . . . . .	11
Distance Measurements, Gradiometer, 28		Mining Lamps, . . . . .	59
" " Stadia, . . . . .	41	" Lamp and Plummet, . . . . .	59
Draughting Scales and Protractors, 70		" " Holder, . . . . .	60
Diagonal Eye Piece, . . . . .	46-48	" Rod and Target, . . . . .	60
Decimal Verniers, . . . . .	47	" TRANSITS, . . . . .	54-58
Engineering Instruments, General		" " Additions to, . . . . .	59
Characteristics, . . . . .	10	" " Tripods, . . . . .	59
Engineer's Transit, . . . . .	48-50	" " double, . . . . .	60
" Chain Tape, . . . . .	75	" Slope Levels, . . . . .	68
" Eye Piece Improvements, . . . . .	32	Needle and Centre Pin, . . . . .	26
" Diagonal, . . . . .	46, 48	Nystrom's Calculator, . . . . .	69
Extension Tripod, . . . . .	59	Paine's Steel Tape, . . . . .	76
Gradiometer, . . . . .	28, 50	Parallel Rule, Rolling, . . . . .	73
Graduations, . . . . .	4, 11	" " and Protractor, . . . . .	72
		Parson's Vernier Scale, . . . . .	73

	Page		Page
Payments, Terms of, . . . . .	2	Telescopes, . . . . .	10, 34, 40
Plane Table, . . . . .	66	" Care of, . . . . .	6
Plummet Mining Lamp, . . . . .	59	" Fastener, . . . . .	33
Pocket Compasses, . . . . .	68, 108	Transits, Characteristics, . . . . .	46
Pocket Sextants, . . . . .	73	" Adjustments, . . . . .	16
Protractors, . . . . .	70, 71	" Prices, . . . . .	48
Railroad Transit, . . . . .	48-50	" Repairs to, . . . . .	8
" Level, . . . . .	43, 45	" City, . . . . .	50, 53
Ranging Poles, . . . . .	67	" Engineer's, . . . . .	13, 48, 50
Reflector Plate, . . . . .	46, 59	" Surveyor's, . . . . .	61
Repeating Circle, . . . . .	52	" Tunnel, . . . . .	53
Repairs to Instruments, Cost of, . . . . .	8	" Mining, . . . . .	54
" " Sending		" Solar, . . . . .	63, 64
them for, . . . . .	9	" Variation, . . . . .	62
Rod and Target, . . . . .	67	" Ranging Poles, . . . . .	67
" " Mining, . . . . .	60	Tripods, . . . . .	7
Rolling Parallel Rule, . . . . .	73	" Attachment, . . . . .	34
Scale, Parsons' Vernier, . . . . .	73	" Extension, . . . . .	59
Selection of Instruments, . . . . .	13	" Half Length, . . . . .	59
Self-reading Level Rod, . . . . .	67	" Shifting, . . . . .	34
Shifting Tripod, . . . . .	34	Variation Transit, . . . . .	62
Slide Protector, . . . . .	33	Verniers, Care of, . . . . .	7
Slope Levels, . . . . .	68	" Decimal Graduation, . . . . .	47
Solar Compass, . . . . .	62	" Improved, . . . . .	36
" " Adjustment of, . . . . .	23	Vertical Arc, . . . . .	47
" " Repairs to, . . . . .	9	Weight of Instruments, . . . . .	48
" Transit, . . . . .	64	Young's Improved Eye Piece, . . . . .	32
Spring Arm Protractor, . . . . .	72	" " Attachment to	
Smith Solar, . . . . .	64	Tripod, . . . . .	34
Surveyor's Compass, . . . . .	65	" " Slide Protector, . . . . .	33
" " Repairs to, . . . . .	9	" " Tangent, . . . . .	33
" Transit, . . . . .	61	" " Web Fastener to	
Stadia Wires, . . . . .	49	Level Telescope, . . . . .	33
Stadia, . . . . .	41	" Improved Patent Telescope, . . . . .	34
Steel Blade Protractors, . . . . .	72	" Self-reading Rod, . . . . .	60
Tangent, . . . . .	33	" Improvement Needle Read-	
Tapes, . . . . .	75, 76	ing Instruments, . . . . .	35

## DRAUGHTING INSTRUMENTS.

	Page		Page
Alteneder's Patent Instruments, . . . . .	91	Curves, Railroad, . . . . .	107
Aneroid Barometers, . . . . .	109	Curve Pen, . . . . .	88, 89
Batter Triangles, . . . . .	107	Dividers, Plain, Swiss, . . . . .	86, 87, 91
Beam Compasses, . . . . .	90, 98	" " German, . . . . .	96
Border Pen, . . . . .	89, 97	" Hair-spring, Swiss, . . . . .	86, 91
Bow Pen, . . . . .	97	" " German, . . . . .	96
Boxes for Instruments, . . . . .	95, 102	" in Sets, Swiss, . . . . .	86, 87, 91, 92
Brass Instruments, . . . . .	103	" " German, . . . . .	96
Cases Swiss Instruments, . . . . .	93, 94	" Bi-section, . . . . .	87
" German " . . . . .	99-101	" Pocket, . . . . .	87
" Brass " . . . . .	103	" Proportional, . . . . .	88
Centres, . . . . .	98	" Spring Bow, . . . . .	88, 97
Cross Section Triangles, . . . . .	107	Dotting Pen, . . . . .	89, 98
Curves, Irregular, . . . . .	108	Drawing " . . . . .	89, 97



Field Glasses, . . . . .	Page 108	Pricking Point, . . . . .	Page 89
German Draughting Instruments, . . . . .	96	Proportional Dividers, . . . . .	88
Hatching Pen, . . . . .	98	Protractors—Horn, Paper, German Silver, . . . . .	104, 105
Opesometer, . . . . .	89	Railroad Curves, . . . . .	107
Paper Tacks, . . . . .	98	“ Cross Section Triangles, . . . . .	107
“ Scales, . . . . .	105	“ Pen, . . . . .	89, 97
“ Protractors, . . . . .	104	Scales—Wood, Ivory, Paper, . . . . .	105
Pen, Border, . . . . .	89, 97	Selection of Instruments, . . . . .	11
“ Curve, . . . . .	89, 97	Spring Bow Pen and Pencil, . . . . .	87, 88, 97
“ Dotting (Roulette), . . . . .	89, 98	Steel Triangles, . . . . .	106
“ Hatching, . . . . .	89, 98	“ Straight Edges, . . . . .	107
“ Railroad, . . . . .	89, 97	Swiss Draughting Instruments, . . . . .	86
“ Red Ink, . . . . .	89, 97	Tracer, . . . . .	89
“ Spring Bow, . . . . .	88, 97	Triangles—Wood, Horn, Rubber, . . . . .	106
“ Straight Line, . . . . .	89, 97	“ German Silver, Steel, . . . . .	106
Pillar Compasses, . . . . .	90, 98	T Squares, . . . . .	104
Pocket “ . . . . .	68, 108	Universal Pillar Compasses, . . . . .	89
“ Dividers, . . . . .	87		

#### ENGINEERS' STATIONERY AND SUPPLIES.

Alphabet Books, . . . . .	Page 121	Mapping Pens, . . . . .	Page 112
Brushes, Camel's Hair and Sable, . . . . .	111	Paint Slabs and Saucers, . . . . .	111
Colors, . . . . .	110	Pencils (Brushes), . . . . .	111
Cross Section Paper, . . . . .	117	Pens, . . . . .	112
“ “ Tables, . . . . .	120	Paper, Drawing, . . . . .	113
Colored Pencils, . . . . .	111	Profile Paper, . . . . .	116, 117
Drawing Paper—Sheets, rolls, mounted, . . . . .	112-117	“ Books, . . . . .	118-121
Field Books, . . . . .	118, 119	“ Field Book, . . . . .	118
Ink, India, . . . . .	112	Specimen Book, . . . . .	121
“ “ Liquid, . . . . .	111	Tiles for India Ink, . . . . .	111
“ Japanese, . . . . .	111	Tracing or Vellum Cloth, . . . . .	113
India Rubber, . . . . .	112	“ Paper, . . . . .	113
Lead Pencils, . . . . .	112	Transit Books, . . . . .	118
“ “ Colored, . . . . .	111	Vellum Cloth, . . . . .	113
Letter (Specimen) Books, . . . . .	121	Water Colors, . . . . .	110
Level Books, . . . . .	118	“ “ Liquid, . . . . .	110

