



This is a digital copy of a book that was preserved for generations on library shelves before it was carefully scanned by Google as part of a project to make the world's books discoverable online.

It has survived long enough for the copyright to expire and the book to enter the public domain. A public domain book is one that was never subject to copyright or whose legal copyright term has expired. Whether a book is in the public domain may vary country to country. Public domain books are our gateways to the past, representing a wealth of history, culture and knowledge that's often difficult to discover.

Marks, notations and other marginalia present in the original volume will appear in this file - a reminder of this book's long journey from the publisher to a library and finally to you.

### **Usage guidelines**

Google is proud to partner with libraries to digitize public domain materials and make them widely accessible. Public domain books belong to the public and we are merely their custodians. Nevertheless, this work is expensive, so in order to keep providing this resource, we have taken steps to prevent abuse by commercial parties, including placing technical restrictions on automated querying.

We also ask that you:

- + *Make non-commercial use of the files* We designed Google Book Search for use by individuals, and we request that you use these files for personal, non-commercial purposes.
- + *Refrain from automated querying* Do not send automated queries of any sort to Google's system: If you are conducting research on machine translation, optical character recognition or other areas where access to a large amount of text is helpful, please contact us. We encourage the use of public domain materials for these purposes and may be able to help.
- + *Maintain attribution* The Google "watermark" you see on each file is essential for informing people about this project and helping them find additional materials through Google Book Search. Please do not remove it.
- + *Keep it legal* Whatever your use, remember that you are responsible for ensuring that what you are doing is legal. Do not assume that just because we believe a book is in the public domain for users in the United States, that the work is also in the public domain for users in other countries. Whether a book is still in copyright varies from country to country, and we can't offer guidance on whether any specific use of any specific book is allowed. Please do not assume that a book's appearance in Google Book Search means it can be used in any manner anywhere in the world. Copyright infringement liability can be quite severe.

### **About Google Book Search**

Google's mission is to organize the world's information and to make it universally accessible and useful. Google Book Search helps readers discover the world's books while helping authors and publishers reach new audiences. You can search through the full text of this book on the web at <http://books.google.com/>

Eng  
535  
18



GODFREY LOWELL CABOT SCIENCE LIBRARY  
*of the Harvard College Library*

This book is  
**FRAGILE**  
and circulates only with permission.

Please handle with care  
and consult a staff member  
before photocopying.

Thanks for your help in preserving  
Harvard's library collections.

ARY

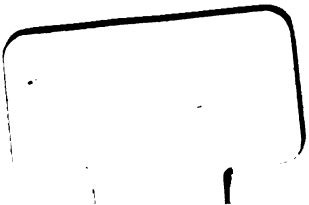

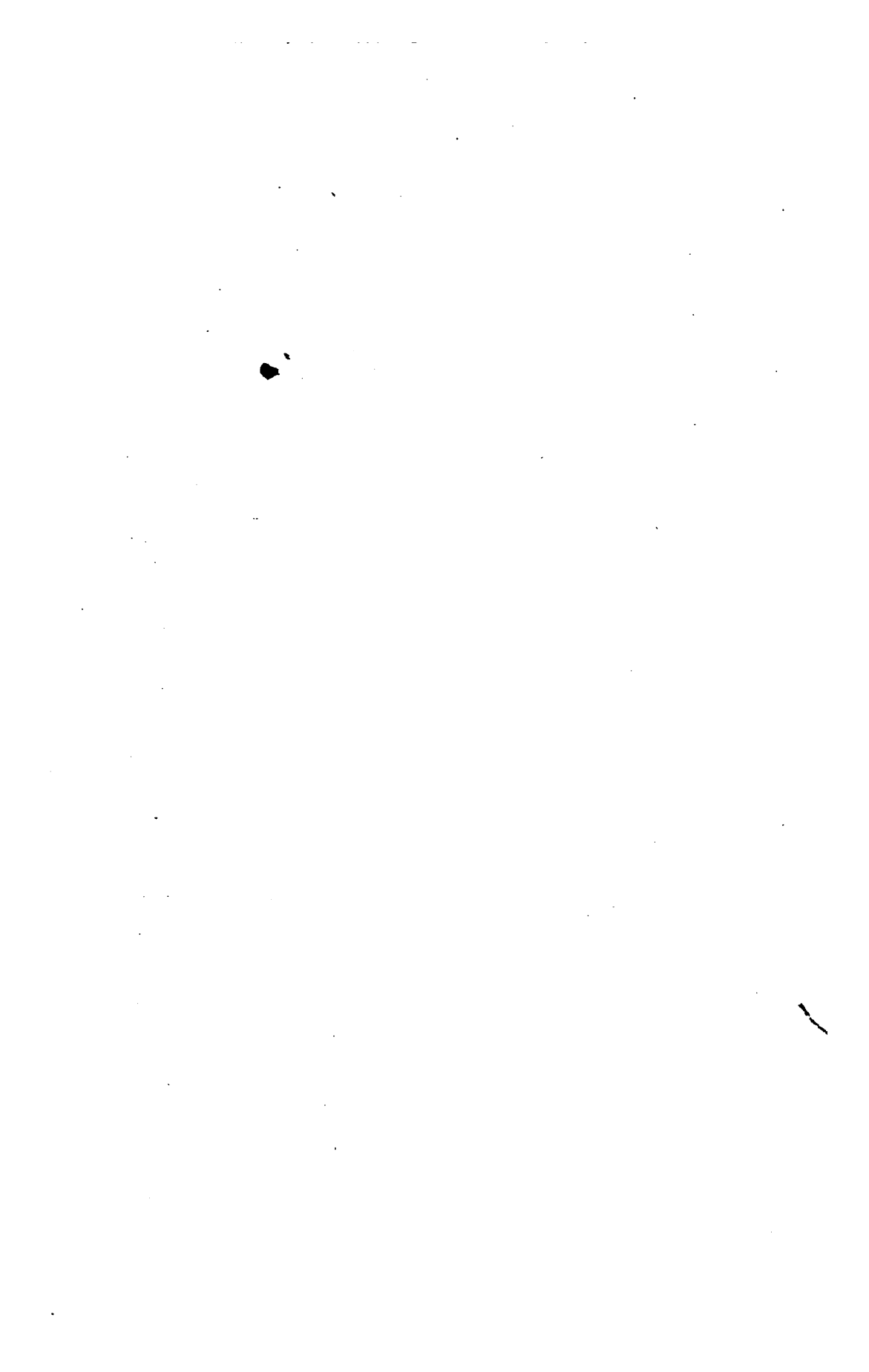

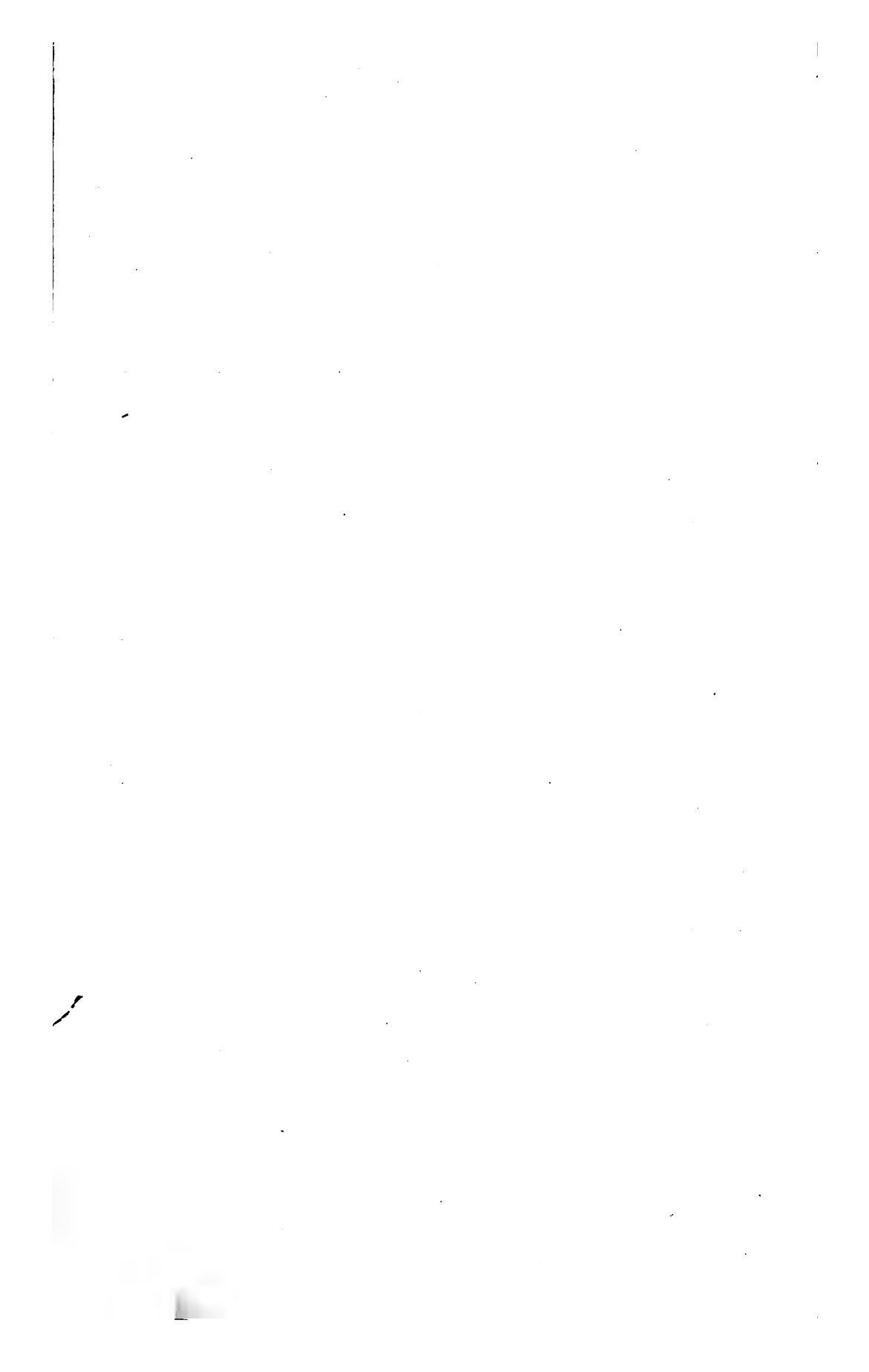



S.

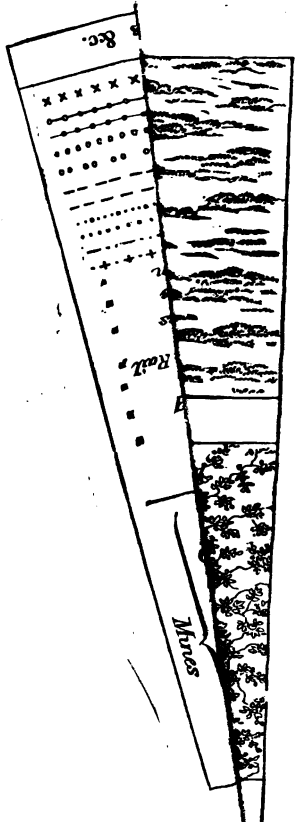

Murus

(ESTABLISHED 1870.)

## REMARKS

ON

# ENGINEERS' SURVEYING INSTRUMENTS.

BY HELLER & BRIGHTLY,

## CONTENTS.

	PAGE		PAGE
<b>POINTS OF A GOOD TRANSIT.</b>		<b>THE MUSCONETCONG TUNNEL.....</b>	<b>40</b>
Defective surveys.—City of Burlington, N. J., in point.—Law compelling instruments to be tested.—Magnetic needle, its degree of sensitiveness.—Compound centres, how to test.—Should always have double verniers, and why.—Dead centre turning lathe.—“Back lash” to tangent screw.—Telescope balanced in axis.....	3	<b>TOPOGRAPHY BY MEANS OF CONTOURS</b>	<b>2</b>
<b>COMMON DEFECTS OF ORDINARY TRANSITS.</b>		<b>SOLAR COMPASS.</b>	
Defective graduation.—Errors of graduation.—Personal equation.—Personal aberration.—Error between Bessel and Struve.—Metal should not be yellow brass, and why.—Defects of ordinary plummet.....	3	How to test.—Methods of applying telescope to.....	14
<b>MINING TRANSITS.</b>		<b>NEW STRAIGHT LINE MEASURE.</b>	
Side telescope to axis.—Improved table for lamp.—New lamp for hat.—Reflector for graduations.....	7	Defects of ordinary tapes and chains.....	18
<b>TUNNEL TRANSITS.</b>		<b>STADIA MEASUREMENTS.</b>	
How made.—Error of alignment.....	7	Different methods.—Why good results not been had.—Starting-point for stadia.....	16
<b>LEVELING INSTRUMENT.</b>		<b>PAPER READ BEFORE THE AMERICAN PHILOSOPHICAL SOCIETY ON TRANSITS</b>	<b>18</b>
Points of a good level.—Marks for vertical line.—New mode of binding telescope.—Defective form of level.—Diversity of opinion, as to close leveling.—Test levels.—K.d errors, how corrected.—Distance errors, how corrected.....	8	<b>REPORT OF A COMMITTEE OF CIVIL ENGINEERS OF THE FRANKLIN INSTITUTE TO EXAMINE A NEW TRANSIT....</b>	<b>22</b>
<b>TELESCOPES.</b>		<b>ACCOUNT OF A NEW TELESCOPE.....</b>	<b>25</b>
How to compare.—Tests for power, definition and light.—Best time for sighting.—How to keep telescope good.....	10	<b>TEST OF NEW TELESCOPE AS COMPARED WITH AN ORDINARY ONE.....</b>	<b>26</b>
<b>SURVEYOR'S COMPASS.</b>		<b>STROLL THROUGH AN “ENGINEERS’ INSTRUMENT” MANUFACTORY.....</b>	<b>28</b>
Remarks on magnetism.—How to keep needle sensitive.—Causes of attraction. New causes of attraction.—Nickel watch movements.—Wire hat-bands.—Impure brass.—Electricity in compass glass.....	11	<b>MODERN PRACTICE OF FIELD WORK IN RAILROAD SURVEYS.....</b>	<b>30</b>
<b>EUROPEAN DEMAND FOR AMERICAN ENGINEERING INSTRUMENTS.....</b>	<b>18</b>	<b>PAPER READ BY PROF. R. W. RAYMOND BEFORE THE AMERICAN ASSOCIATION OF MINING ENGINEERS ON A NEW MINING TRANSIT.....</b>	<b>32</b>
		<b>PAPER BY ECKLEY B. COXE, ESQ., BEFORE THE SAME, ON THE USE OF THE PLUMMET LAMP IN MINE SURVEYING</b>	<b>33</b>
		<b>ACCURACY OF AMERICAN CIVIL ENGINEERING.....</b>	<b>40</b>
		<b>TOPOGRAPHICAL CONVENTIONAL SIGNS</b>	
		<i>Frontispiece.</i>	
		<b>“INSTRUMENTS OF PRECISION” for EDUCATIONAL INSTITUTIONS.....</b>	<b>42</b>

## CENTENNIAL ENGINEERING FACTS.

<b>AN UNSUSPECTED SOURCE OF ERROR IN MAGNETIC NEEDLE READINGS OF SURVEYING INSTRUMENTS.....</b>	<b>5</b>	<b>SURVEYORS AT THE CENTENNIAL.....</b>	<b>3</b>
<b>FESTS AT LONG RANGE OF FIRST-CLASS TELESCOPES.....</b>	<b>4</b>	<b>RANGE OF AN ORDINARY TRANSIT TELESCOPE.....</b>	<b>3</b>
<b>A PLEASANT INCIDENT OF THE CENTENNIAL YEAR.....</b>	<b>3</b>	<b>“THE FINEST MINING TRANSIT IN THE PACIFIC COAST”.....</b>	<b>5</b>
<b>COLLEGES AND THE CENTENNIAL.....</b>	<b>3</b>	<b>THE LARGEST ORDER FOR SURVEYING INSTRUMENTS EVER GIVEN IN THE UNITED STATES.....</b>	<b>5</b>
<b>EXHIBIT OF HELLER &amp; BRIGHTLY AT THE CENTENNIAL.....</b>	<b>2</b>	<b>THE PRIZE FOR IMPROVEMENTS AND PROGRESS IN INSTRUMENTS AT THE CENTENNIAL.....</b>	<b>1</b>
<b>BASE LINE MEASUREMENTS WITH STEEL TAPES.....</b>	<b>4</b>	<b>KENSINGTON LOAN COLLECTION OF SCIENTIFIC INSTRUMENTS AND THE CENTENNIAL.....</b>	<b>4</b>
<b>FOREIGN AND AMERICAN SURVEYING INSTRUMENTS AT THE CENTENNIAL.....</b>	<b>1</b>		

PHILADELPHIA:

Published by HELLER & BRIGHTLY,

S. E. Cor. Spring Garden & Ridge Ave.,  
1889.

COPYRIGHT, 1889, BY HELLER & BRIGHTLY.



Eng 535.18

HARVARD UNIVERSITY  
SCHOOL OF ENGINEERING

## PREFACE TO THE FIRST EDITION.

OFFICE OF HELLER & BRIGHTLY,  
PHILADELPHIA, February, 1874.

JUN 20 1917  
TRANSFERRED TO  
HARVARD COLLEGE LIBRARY

## THE ENGINEERING PROFESSION.

When we some three years since first introduced our "Improved Transit" to the Engineering profession, we had no idea that it would meet with so immediate favor as it has, especially as we made no particular efforts to spread the knowledge of the improvement. The first public knowledge was conveyed through the paper read before the American Philosophical Society by J. PETER LESLEY, Esq., Dean of the Faculty of the new Department of Science of the University of Pennsylvania, as well as Professor of Mining and Geology in that institution; than whom no person is better qualified by extensive practice in the field to judge of the quality of Surveying instruments. On the publication of this paper, we resolved to submit our instruments to a committee of experts to be appointed by the Franklin Institute of Philadelphia. This committee was composed of the following gentlemen: JNO. C. TRAUTWINE, Civ. Eng., author of the "Engineers' Pocket-Book," works on "Excavations," "Curves," etc., and whose knowledge regarding all matters connected with Civil Engineering is too well known to need recapitulation, was Chairman; SAML. L. SMEDLEY, Chief Engineer and Surveyor of the city of Philadelphia; CHAS. S. CLOSE, Esq., of the Philadelphia Survey Department; L. M. HAUPT, Civ. Eng., Prof. of Civil Engineering in the University of Pennsylvania; and ELLWOOD MORRIS, Civ. Eng., author of "Earthworks," formerly Chief Engineer of the Ohio and Chesapeake Canal, and of other works, being the remaining members. After a thorough examination in whole and in detail of the instruments and the principles of their construction, they unanimously made the report that will be found in the body of the pamphlet. In proof of the sincerity of the opinions of each individual member of the committee, we may state that since the report was submitted, the Survey Department of the city have procured from us *all* the new instruments required since that date, amounting to eight in all; also that the University of Pennsylvania have purchased from us all the Engineering instruments required by that institution; and, moreover, we have sold instruments either to every member of the committee directly, or to other Engineers at their recommendation.

As we have in the last three years made two improvements in Telescopes, a word of explanation may be necessary to distinguish them apart. In 1870 we improved the formula in general use for Telescopes in such a manner as to practically annihilate the chromatic and spherical aberration. This Telescope is the one referred to in the Philosophical Society paper, and in the report of the Franklin Institute Committee of Civil Engineers; and this Telescope is on all of our instruments from No. 4100 to No. 4592 inclusive. (All of our instruments are numbered on the face.)

Early in 1873 we commenced experimenting in order to increase the power of our Telescopes, and we only brought our experiments to a perfectly satisfactory conclusion in the latter part of December of the same year. We have made but comparatively few instruments with this new Telescope attached (from No. 4593 to 4645 inclusive). This latter Telescope is, however, the one which we are now placing on *all* of our new instruments; and it was with a Telescope of this kind on a Transit that we made for the City of Philadelphia Survey Department, that the comparisons as to power, range and definition, as compared with an ordinary Transit Telescope, were made by Mr. Stauffer.

The articles extracted from the editorial columns of the *United States Railroad and Mining Register* will give the full details concerning the "Improved Telescope;" and the "Franklin Institute Report" first sees the light in these pages. Having within a short time doubled our force of skilled workmen and tools, and having also called in the aid of steam, we hope in the future to supply any reasonable demand on us for instruments, and to avoid the vexatious delays that we heretofore frequently have had to subject our friends.

## PREFACE TO THE FOURTH EDITION.

OFFICE OF HELLER & BRIGHTLY,  
PHILADELPHIA, June, 1875.

To the Engineering profession we herewith present the fourth edition of our pamphlet, materially enlarged and, we hope, improved. Through the kindness of Mr. Trautwine we are enabled to give all the errors that have been detected in his "Civil Engineer's Pocket Book." For the privilege of inserting the valuable sheet of "Topographical Conventional Signs" we are indebted to Prof. Haupt, of the University of Pennsylvania, the following letter from whom we insert.

1807 CHRISTIAN ST., PHILADELPHIA, Nov. 30, 1874.

MESSRS. HELLER & BRIGHTLY:

GENTLEMEN.—Having for many years felt the necessity for a set of Conventional Signs for Topographical Engineers which should be condensed and accurate, I have compiled the accompanying chart for use in the University of Pennsylvania and the Engineering profession in general, believing that it will supply a long-existing want in this class of information.

They are compiled from the best American and English authorities and carefully classified, making any explanations superfluous.

Yours, very respectfully,

LEWIS M. HAUPT,  
*Professor Civil Engineering.*

## PREFACE TO THE SIXTH EDITION.

January 1, 1876.

Through the kindness of Prof. Haupt and of the Civil Engineering section of the Class of '76 of the University of Pennsylvania, we are enabled to give in the present edition the valuable plate, "Study in Contours," and its explanatory description.

## PREFACE TO THE FOURTEENTH EDITION.

In this our fourteenth edition we hope our friends will find fresh matter of interest. We have endeavored to make this pamphlet of more value than merely as a price-list, and we think our efforts have not been in vain, from the fact of its having been (on account of its Table of Topographical Signs, Topographical Contours, etc.) adopted as an auxiliary class-book in eight colleges. The table of express charges on engineering instruments to or from any part of the United States, and the method of sending parts of instruments by mail, will also be found of value.

We must apologize for the typography, binding, etc., of the seventh, eighth, ninth, tenth, and eleventh editions, as the demand for it from visiting Surveyors and Engineers during and after the Centennial year required us to furnish the pamphlet rather quicker than was consistent with good printing (four editions were called for during the Centennial year, we having distributed an average of one hundred copies daily at our exhibit in the Main Building).

As we have made several changes in our prices, the present Price List (to be found at the end of the book) will supersede all others.

HELLER & BRIGHTLY.

PHILADELPHIA, May, 1878.

## TOPOGRAPHY BY MEANS OF CONTOURS.

UNIVERSITY OF PENNSYLVANIA,  
Philadelphia, Nov. 20, 1875.

MESSRS. HELLER & BRIGHTLY.

GENTLEMEN: In compliance with your request I have prepared a reduced plot to show the method of representing topography by means of contours.

As such information can only be intended for amateurs, I will explain the method in detail and show some of its applications to location.

If a series of *horizontal* planes be assumed at equal distances apart, they will intersect an irregular or inclined surface in lines; or if a water level be supposed to be raised or lowered by equal stages, the successive water-lines or edges thus formed will represent the contour lines of the surface. These contours or horizontal sections are shown by projecting them upon a horizontal plane.

In the case in question, the lowest point of the field was found, and the horizontal plane passing through it assumed as the zero or datum plane, upon which all the other contours were projected. The interval between the planes was assumed to be three feet, and the points on the surface at these various elevations, having been first determined by the level and rod, were located by the plane table.

This method of representing topography is vastly superior to any other, as it exhibits exactly the slope at any portion of the ground; gives the elevation of the base of any object within the tract; enables one to make vertical sections in any direction with accuracy from the plot, and to locate roads, paths or other features upon a given grade or at any desired elevation, and furnishes the means of calculating the contents of irregular solids with great precision.

To locate a road upon a given grade, say— $\frac{1}{100}$ : take with the dividers from the scale one hundred feet, and starting from a given point—say P—describe an arc from it as a centre, cutting the next lower contour (27) from this intersection as a centre; with the same radius describe an arc cutting (24), and so on. The line joining these centres will be a surface-line on the given grade, and will be the cheapest road that can be built upon the given conditions. Crossing the stream at (T T'), upon a level 6' above the water, to reach the top of the hill at V the grade must be increased to  $\frac{1}{80}$  or  $\frac{1}{80}$ ; and the centre line is located in the same manner, but with a radius of 60', as that will be the base for a rise of three feet. Descending from V to W, the grade is the same; but from W to X it is reduced to  $\frac{1}{100}$  or  $\frac{1}{100}$ , to prevent cutting at X. From Z back to P two routes are shown, which are the shortest for the given grade  $\frac{1}{100}$ , although a third might be located following the stream to a point M, where it must be diverted to N, and thence zigzag up the hill, but it would be longer than the others. The two distances ZxyzSR and Zx'y'z'R are equal; but the first gives a more graceful curve and will require less construction, the part SR being supposed to have been already built for the descending grade.

These are a few of the applications of this system of projections. It is also of great use in dividing up land, computing areas, locating a system of drainage, etc.

Yours very truly,  
LEWIS M. HAUPT,  
PROF. OF CIVIL ENGINEERING.

To accompany HELLER & BRIGHTLY'S  
*Remarks on Engineer's Surveying Instruments.*

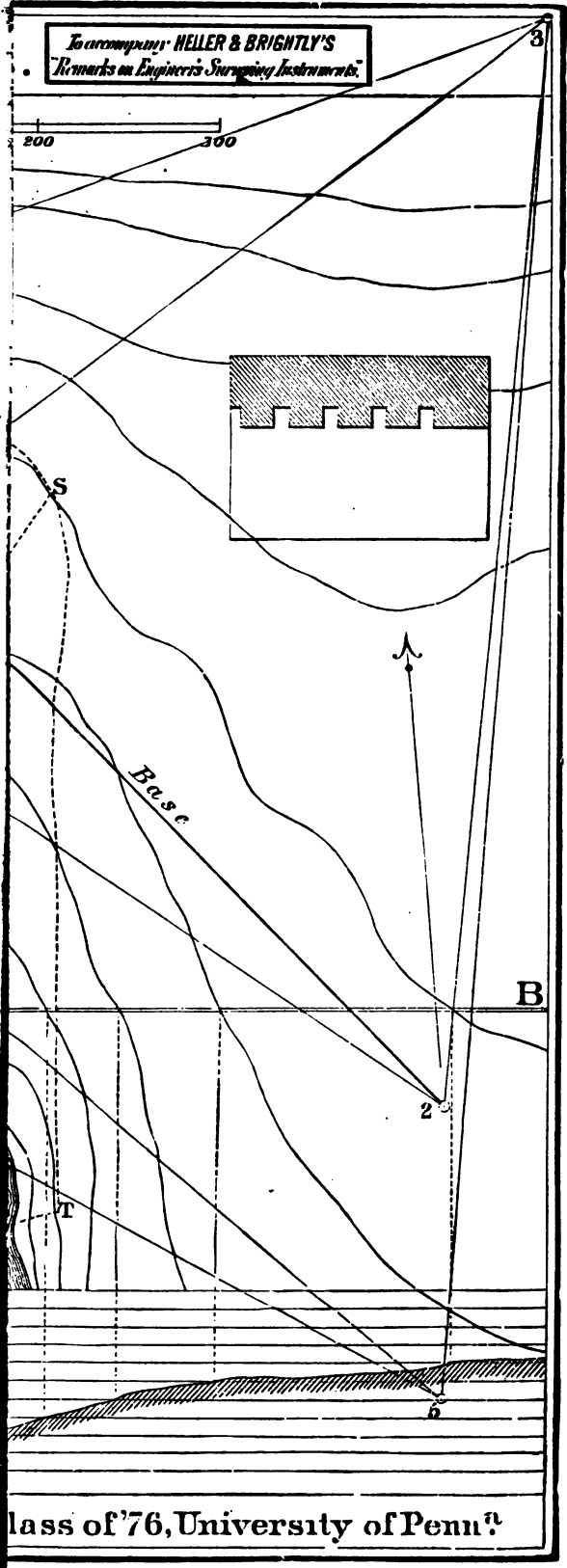
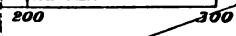

Class of '76, University of Penn<sup>a</sup>

NA,  
inced  
are  
plain  
they  
el be  
lines  
hese  
tor:  
the  
me,  
the  
ese  
ere  
er,  
ra-  
al  
ls,  
nd  
at  
5

1  
H H H H N O O O O S S S S

# CENTENNIAL ENGINEERING FACTS

## CONTENTS.

PAGE	PAGE
<p><b>FOREIGN AND AMERICAN SURVEYING INSTRUMENTS AT THE CENTENNIAL</b>..... 1</p> <p><b>THE PRIZE FOR IMPROVEMENTS AND PROGRESS IN INSTRUMENTS AT THE CENTENNIAL</b>..... 1</p> <p><b>EXHIBIT OF HELLER &amp; BRIGHTLY AT THE CENTENNIAL</b>..... 2</p> <p><b>COLLEGES AND THE CENTENNIAL</b>..... 4</p> <p><b>BASE LINE MEASUREMENTS WITH STEEL TAPES</b>..... 4</p> <p><b>TESTS AT LONG RANGE OF FIRST-CLASS TELESCOPES</b>..... 4</p>	<p><b>A PLEASANT INCIDENT OF THE CENTENNIAL YEAR</b>..... 3</p> <p><b>SURVEYORS AT THE CENTENNIAL</b>..... 3</p> <p><b>RANGE OF AN ORDINARY TRANSIT TELESCOPE</b>..... 3</p> <p><b>KENSINGTON LOAN COLLECTION OF SCIENTIFIC INSTRUMENTS AND THE CENTENNIAL</b>..... 4</p> <p><b>"THE FINEST MINING TRANSIT IN THE PACIFIC COAST"</b>..... 5</p> <p><b>THE LARGEST ORDER FOR SURVEYING INSTRUMENTS EVER GIVEN IN THE UNITED STATES</b>..... 5</p>

### FOREIGN and AMERICAN SURVEYING INSTRUMENTS at the CENTENNIAL. THE PRIZE FOR IMPROVEMENTS AND PROGRESS.

(Engineer, November, 1876.)

AMONG the least appreciated exhibits at the Centennial by the general visitor were those of the Surveying Instrument Makers; but seldom has there been seen together in one place (certainly never before in this country) so many specimens of different makes, and to one so inclined a fine opportunity was offered to study the different constructions; but very bad judgment was displayed in distributing this class of instruments over so many buildings, as the majority of surveyors and engineers supposed, after examining the principal exhibits in the Main Building, that they had seen all in this line, not knowing that in the Coast Survey and War Department exhibits in the U. S. Government Building, in the separate Spanish and French buildings (Travaux Publics, Ponts et Chaussées, etc.), and in the room of the Society of Civil Engineers were numerous other instruments. Among the instruments to be seen from makers in the United States were those from Heller & Brightly, Wurdemann, Stackpole, Gurley, Prentice, Alfred Young, Knox & Shain, Fauth & Co., Kuebler & Seelhorst and others; while Troughton & Simms, Dallmeyer, Cassela, Negretti & Zambra, of London, Pistor & Martin, Ertel & Sohn, of Germany, Gambey, Brunner, Rigaud and Secretan, of France, Lgunstrom and Rose, of Sweden, besides others from Spain, Portugal and Russia, etc., made a full European representation.

The judges who had been selected to examine these instruments were all experts, the members from this country being Prof. Hilgard, of the U. S. Coast Survey, Prof. Henry, of the Smithsonian Institute, Prof. Watson, Michigan State University, Prof. Barnard, of Columbia College, together with Prof. Kupka, of Austria, Prof. Levasseur, of France, Favre Peret, of Switzerland, and three others. The decision and awards that these gentlemen have made have just been given to the public. HELLER & BRIGHTLY are lucky ones, the especial point made by the judges being their late improvements (these improvements being their improved tripod head, tripod telescope and tangent screws—the reducing the weight of instrument and making it more compact, etc.). It seems like poetic justice, however, that this firm, whose instruments we understand were exclusively used to lay out the buildings and grounds of the Centennial Exhibition, should receive the highest award in its gift. Two foreign members of the commission, Kupka, of Austria, and Levasseur, of France, were especially searching in their examination of the American styles of instruments. There was, however, a reason for this, as Mr. Kupka, besides his duties as judge, has also to make a full report to the Austrian government on his return home on the present state of science in this country; and as one result of his examination, he requested Messrs. Heller & Brightly to prepare for him drawings, showing in detail the various sections of their instruments, as he wished to incorporate them in his report as specimens of representative American instruments.

(From the *Chicago Engineering News*, September 2, 1876.)

FROM ARTICLE ON "THE ENGINEERING INSTRUMENTS AT PHILADELPHIA," BY THEIR SPECIAL CORRESPONDENT, PROF. J. B. DAVIS, UNIVERSITY OF MICHIGAN, ANN ARBOR, MICHIGAN.

Among the most prominent exhibits of this class is that of Messrs. Heller & Brightly, of 33 N. Seventh street, Philadelphia. This is the firm that have done more than any other in this country of late years to increase competition in the trade, and to wake up the different makers to a sense of the many improvements that may be made in the instruments in common use. Indeed, it was said of them by one of their powerful rivals that they had made more progress in the manufacture and improvement of their instruments than any one else. The gentleman really went further than I am ready to accompany him when he said that they were the only ones who had advanced much, if any, from previous practice. Whilst I regard this as far from an exact statement, it illustrates the respect in which they are held by those who compete against them. They have on exhibition a fine collection of their various products. Here is a list of what may be seen: Two engineer's Y-levels, complete transit for mining use, plain engineer's transit, geological transit, 4-inch limb; tunnel transit, used at the Musconetcong and Nesquehoning tunnels; surveyor's compass; solar transit, Benj. Smith Lyman's patent solar apparatus beneath the plate; mining and reconnaissance level; combined transit and leveling instrument; two mining and reconnaissance transits, 5-inch limb; large mining transit, 7-inch limb; and a plane table. Now, there is not one of these instruments that does not show in some one or more ways the inventive genius of the firm. There are numerous details worked out and devised to improve upon old ones. It gives great pleasure to be able to say that in almost every instance the change is an improvement. \* \* \* It can be said with great force that in the work of this firm is the place to hopefully look for real improvements. Whoever is to invest in instruments should give them an examination. It is of course quite impossible to mention all of the devices shown here; but a few will be given. The large mining transit has an adjustable lamp-stand provided with it. This stand may be easily fastened upon one of the legs of the tripod, and may be quickly set so as to support a lamp at the proper place for illuminating the cross-wires or for reading the verniers. The same transit is provided with an extra detachable telescope on the end of the transit axis for sighting in a vertical direction. The device for attaching this telescope is neat and efficient. There is also shown a large 15-second transit with three leveling screws. This instrument is provided with an arrangement of parts in the tripod cap that operates in a manner to accomplish the same result as is accomplished by the ordinary shifting tripod cap, or "shifting tripod," as it is called. I think this arrangement for a three-screw instrument is new. \* \* \*

In closing my remarks about the exhibits of this firm, I wish to say that I think their most valuable contribution to the advancement of their business is the spirit of invention and adaptation which they have awakened amongst their competitors. Since I believe we have not seen the full development of good principles of construction in our common instruments, I look for particularly valuable results from the spirit above alluded to. Whilst I regard with satisfaction the disposition of engineers to adhere to well-trying and valuable types of construction in any department, I am sure this conservatism may be carried too far and much be lost thereby. I think this has been the case with those who have had to use engineers' instruments. I am of the opinion that much has yet to be done to induce men to be ready and willing to try any new device applied to these constructions. The practice in this regard seems to have improved much within a few years, but there is much to be done. It is in the hope that these remarks may lead some to consider this matter that they are written.

I cannot close my account of this firm without mention of the excellent plummet-lamp shown by them. One is provided with a "compensating ring," which is simply a ring upon the sides of which rest two trunnions, from the plummet and from opposite sides of 90°; from the other points proceed two light chains, which meet some ways above the plummet where the string is attached; the lines of the attachment of the chains and the bearings of the trunnions are consequently at right angles with each other. Another has, in addition to this ring, in the place of an ordinary burner, a safety-lamp. Both arrangements are the invention of Professor Eckley B. Cox. \* \* \*

The transits shown by Kern of Aarau, Switzerland, have three leveling screws and open spoke-wheel plates. Of course they are very light. Wyes start out from centre of upper plate; there are levels on top of the telescopes; the telescopes are not

mounted near their centre of gravity, and are therefore balanced by great pieces of brass of irregular shape, fastened to their lighter ends, giving this part of the work a decidedly clumsy appearance. This is especially true after one has recently seen and tried the movement of the five Heller & Brightly telescopes. One is surprised at every point, in examining the work of this Philadelphia firm, to see the extreme care and judgment with which every detail is worked out. One cannot well help referring the work of other makers to theirs as a kind of standard with which to compare it.

### RANGE OF AN ORDINARY TRANSIT TELESCOPE.

MESSRS. HELLER & BRIGHTLY,

ST. PAUL, MINNESOTA, Nov. 8, 1876.

\* \* \* \* With the Transit you furnished me last spring year (July, 1875) I have made a triangulation extending over an area of about 12 square miles; it is a success. The angles are only repeated three times; and if a difference of 10'' (ten seconds) between least and greatest is shown, the set is rejected and a new one taken on a different part of the limb, but this is never required. As for the telescope, I have seen the ordinary wooden support of a lightning-rod (probably 1½-inch diameter) quite distinct at 10 miles distance, and not very clear air at that. As to adjustment, the instrument is yet in perfect adjustment. \* \* \* \*

Yours, etc., JOHN T. HALSTEAD.

(From the Philadelphia Commercial Times, Nov. 2, 1876.)

### A PLEASANT INCIDENT OF THE CENTENNIAL YEAR.

On the evening of September 14 a number of the former students and members of the Alumni of the Polytechnic College of this city, temporarily residing here, "doing the Centennial," met to compare notes and exchange greetings. During the course of conversation it was suggested that a set of engineers' field instruments (transit, level, etc.) be purchased by those present and presented by them to the college, as a mark of regard. The idea immediately took root, the money subscribed, and a committee appointed the same evening to procure the best and most modern instruments. The fact may not be generally known that the instrument makers are always anxious (with an eye to future business with the budding students) to supply colleges and institutes of learning, and are willing to reduce their prices considerably to accomplish this end. The present was no exception to this rule; and quite a contest arose among the makers of this city and other cities for the honor of supplying these instruments, and large discounts from regular prices (from 30 to 50 per cent.) would have been allowed by all the makers. After examining all the makes, the committee unanimously gave the order to Heller & Brightly of this city. This result was the more complimentary to these makers as they were the only ones that refused to make any reduction from their regular prices.

(Educational News, Oct. 18, 1876.)

### COLLEGES AND THE CENTENNIAL.

Our foreign visitors who have visited the principal colleges that make a specialty of teaching civil engineering have found them in an exceptional good condition. In expectation of these visits, the majority of them have the last few years been setting their houses in order, purchasing new instruments, and refurbishing up the old ones. It is "an ill wind that blows nobody good," and this universal renovating has proved profitable to the instrument makers. Messrs. Heller & Brightly have in the last four years furnished fifteen of these institutions with new full sets of field instruments, and have now in hand orders from eight others, the Michigan State College at Lansing, Michigan, being the last to fall in line.

(Engineering Times, Nov. 4, 1876.)

### SURVEYORS AT THE CENTENNIAL.

The records kept in the room of the Society of Civil Engineers in the Main Building, and in the Franklin Institute room in Machinery Hall, show that the number of European scientists and civil engineers who have crossed the Atlantic has exceeded the expectations of the most sanguine. As to the number of home civil engineers and surveyors who are visiting the Centennial, some idea may be formed from the fact that Messrs. Heller & Brightly have at present a daily average of 150 visitors of this class at their exhibit in the Main Building, and have distributed over 1500 copies of their pamphlet, "Remarks on Engineers' Surveying Instruments," at the same place.



### Kensington Loan Collection of Scientific Instruments and the Centennial.

The special loan collection of scientific instruments now on exhibition at the South Kensington Museum, London, is especially barren in American exhibits. This is due, however, to the Centennial Exhibition absorbing all the attention of those interested. The Coast Survey, Meteorological and War Departments could have furnished some interesting specimens had this not intervened. In the "Handbook to the Loan Collection" (article on Scientific Apparatus, etc.) special mention is made by Prof. W. Warington Smyth of the instruments of Messrs. Heller & Brightly of Philadelphia. Messrs. Heller & Brightly were specially requested by those in charge to send specimens of their instruments as samples of American engineering instruments, but could not accept the invitation from causes above mentioned.—*Railroad World*, Nov. 12, 1876.

### BASE LINE MEASUREMENTS WITH STEEL TAPES.

ENGINEERING DEPARTMENT,  
SCHOOL OF MINES, COLUMBIA COLLEGE,  
FORTY-NINTH ST., COR. FOURTH AV.,  
NEW YORK, NOV. 6, 1877.

MESRS. HELLER & BRIGHTLY: \* \* \* \* The Senior class are triangulating the lower half of the Park. \* \* \* \* One of the first triangles (measured with 18 repetitions of each angle) closed within 0'.02''.

Our base line was measured with a HELLER & BRIGHTLY 500 feet tape, hung clear of the ground, the depth of the catenary and level of end measured, and corrections made for inclination, temperature, catenary, stretch of tape, etc. The results as corrected were as follows:

Corrected Length.	Error.
760.0267	0.0086
760.0434	0.0131
760.0510	0.0045
Average 760.0353	0.0036 probable error.

\* \* \* \* \*

Respectfully,

HENRY S. MUNROE,  
Adjunct Professor of Surveying.

### TESTS AT LONG RANGE OF FIRST-CLASS TELESCOPES.

UNITED STATES ENGINEER'S OFFICE,  
85 WASHINGTON AV.,  
DETROIT, MICH., NOV. 28, 1877.

HELLER & BRIGHTLY, Philada., Pa.: \* \* \* \* The instrument (purchased last summer by Gen. Weitzel) has been used during the summer for the purpose intended—to establish bench marks—and it answered the purpose perfectly. I generally took three sets of bench marks, the three almost invariably agreeing within 0.001 feet. The adjustment kept well. \* \* \* \*

I made a few tests with the power of the telescope on the 19th inst., the results of which are given below. Your telescope was compared with a Gurley level telescope, and with a telescope belonging to a Würdemann level. The target inclosed (paper with three one-quarter inch stripes—two black and centre one of white—stripes one inch long) could be seen with about equal distinctness at the following distances:

Heller & Brightly telescope.....	1904 feet.
Würdemann telescope.....	1864 "
Gurley telescope.....	1237 "

The dimensions of the three telescopes were as follows:

	Length over all
Heller & Brightly.....	18 inches.
Würdemann.....	18 "
Gurley.....	19 "

\* \* \* \* \*

Very respectfully yours,

ALFRED NOBLE,  
Assistant Engineer.

**"THE FINEST MINING TRANSIT ON THE PACIFIC COAST."**

SAN FRANCISCO, CAL., Feb. 27, 1877.

**HELLER & BRIGHTY:** \* \* \* \* The complete Engineer's Transit, full size, I ordered of you a year ago, for the New Almaden Quicksilver Mine, I have often referred to as the finest instrument that ever came to the Pacific Coast. It was a pleasure to use it. I have delayed acknowledging the receipt of the small Mining and Reconnaissance Transit until I should be able, after testing in the field, to report fully upon its merits. I will now say that it gives the most entire satisfaction in every respect. The telescope is remarkably clear and perfect, and, small as it is, gives better results at long ranges than one of \* \* \* \* \* full size. The graduations and centering are also very exact. I am using it upon some very long township and ranche boundary lines, depending entirely upon the graduated horizontal limb, and find no trouble in closing circuits of fifteen or twenty miles. \* \* \* \* \*

CHARLES T. HEALEY, C. E.,

Engineer New Almaden Quicksilver Mine,  
Acting Engineer of the Guadalupe Quicksilver Mine.**THE LARGEST ORDER FOR SURVEYING INSTRUMENTS  
EVER GIVEN IN THE UNITED STATES.***(Engineer, December 1, 1877.)*

The new course of studies in the School of Mines of Columbia College (New York City), as mapped out by the authorities, will require a decided increase in the number of field instruments as compared with those heretofore used by Professor Vinton. When fully organized, thirty-eight transits, levels and plane-tables will be required, the cost for these three items alone amounting to over eighty-three hundred dollars. MESSRS. HELLER & BRIGHTLY, of Philadelphia, who furnished the field instruments for the University of Pennsylvania, Princeton College, Dartmouth College and the University of California, have also received the contract for furnishing these instruments to Columbia College.

*(Engineering and Mining Journal, New York, December 8, 1877.)*

One of the largest orders which has been given in this country for surveying instruments was recently given by Columbia College, of this city, to the well-known manufacturers, MESSRS. HELLER & BRIGHTLY, of Philadelphia. The first installment of this order, consisting of eight combined transit and leveling instruments, four Y-levels and four plane-tables, has just been delivered. The requirements of the School of Mines, under the "new departure" inaugurated by Professors Trowbridge and Munroe, will call for over three dozen transits, levels and plane-tables.

*[From the Engineering and Mining Journal, New York, Jan. 26, 1878.]***AN UNSUSPECTED SOURCE OF ERROR IN MAGNETIC  
NEEDLE READINGS OF SURVEYING INSTRUMENTS.**

While engaged in taking some delicate bearings with a surveyor's compass, the writer was puzzled by the magnetic needle not giving the bearing of the same object twice alike; this sudden vagary of the needle was the more unaccountable from the fact that the compass was an exceptionally good one, with extra sensitive needle, and had heretofore always given very good results. An investigation was had as to the cause of the inaccuracies, and from the nature of them it was thought that "magnetic attraction," in the shape of iron in the metal of the instrument itself, might be the cause; but an examination with a "test needle" proved this not to be the fact. The clothes of the observer were then carefully searched for anything that might have a tendency to draw the needle from its proper settling-place; but no pen-knife, steel watch-chain, nickel-plated sleeve-buttons, etc. could be found. It was, however, noticed while reading the needle that it never quite settled, but was in a constant tremor and vibration, and an examination of the magnifying glass used in reading the needle was made. The magnifier was similar to those now so universally used to read the verniers and needle-bearings of field instruments, having a black hard rubber or vulcanite frame, and this frame polished to a high gloss: and the whole cause of the trouble lay in this case or frame.

It was found that this frame was peculiarly liable to become electrified; that the slightest friction, even the mere carrying in the pocket, was sufficient to charge it; and that when thus electrified, if brought near the needle of a compass, it had almost the effect of a loadstone in drawing it (sometimes as much as half a degree of arc) from its true settling-place. On discarding this magnifier, and using an ordinary glass lens without a frame, no further trouble was found in the field-work done with the compass. As all the instrument-makers of this country furnish these hard rubber frame magnifiers with their field instruments, the liability of these frames to become thus electrified should be made known. Any surveyor having one of this class of magnifiers can convince himself of this fact in the following manner: Tear tissue paper or newspaper into small shreds; rub the frame of his magnifier briskly on the coat sleeve for a few moments; this friction will so charge the frame with electricity that, if held above the paper, the paper will fly up and attach itself tightly to the frame, or if held near to the "test magnetic needle" (which all instrument-makers use to prove their metal's freedom from iron) the needle will instantly be drawn to the frame, and stick there as if it were made of iron. This electrical trouble was found to be at its greatest in clear cold weather, and when the rubber cases were new and highly polished; greasing the cases was found to somewhat diminish the evil, and touching with the damp finger also discharged the electricity somewhat. Examination was also made of other magnifiers, those with brass, German silver and horn frames, such as are sold in optical stores, and on testing with the "test needle," the majority were found to be afflicted with "magnetic attraction," arising from impure metal in their cases, rivets, etc.

In consequence of these examinations one firm (Heller & Brightly of Philadelphia\*) have ceased furnishing these rubber magnifiers with their instruments, and have substituted other frames that will stand the test of the "test needle." In connection with this subject the following remarks, while not new, may not be out of place: "Be sure that nothing to attract the needle is carried by the surveyor in the shape of penknives, watch-chains, buttons, or iron rivets in the magnifier used to read the graduations. Of late years new causes of error from this have risen. The new watches in which the movements are made of nickel are almost as powerful in attracting the needle as if those movements were made of iron. The felt-hat makers' modern fashion of stiffening the rims of their hats by inserting around the edge a small iron wire (the extra broad-brimmed, termed the 'military,' should especially be tabooed) should make the surveyor examine both his hat and his watch."

There is, however, a general ignorance (especially among land surveyors) on this important subject, and one case that lately came under the writer's notice will be given in point: A land surveyor, not fancying the brassy look of his compass, had the entire instrument, with its ball and socket and sights, nickel plated, not knowing that as far as its effect on the needle was concerned he might as well have coated his instrument with iron. Aluminum has also been used instead of brass for instruments, but on account of the metal having "magnetic attraction" it is not suitable for needle instruments; this attraction is especially noticeable after the hammering process that is necessary to condense the aluminum after casting; this hammering "polarizing it," as it were.

\* These "non-magnetic attraction frame magnifiers" furnished by us are precisely similar in appearance to the hard-rubber frames mentioned above (the glass itself is, however, sharper defining than the ordinary store glasses), but with the important exception, that these horn frames cannot be excited electrically, as is the case with the rubber. Care is also taken that no magnetic attraction enters into the composition of the various pins and rivets, and that, when fully completed, they shall stand the severe test of the "test needle." If any surveyor who has been troubled with this electricity in his magnifier will send us in a letter one dollar and sixty cents, we will, per return mail, forward to his address one of these magnifiers, post-paid. HELLER & BRIGHTLY.

(From the Polytechnic Journal, April 27, 1878.)

## **BRONZING SURVEYORS' COMPASSES AND TRANSITS WITH A THIN COAT OF IRON.**

An old engineer friend in writing to us says: "It is the almost universal practice of American instrument-makers to produce the beautiful dark color with which the instruments are darkened before lacquering by means of a dip consisting of iron dissolved in muriatic acid." Our correspondent is correct as to the evil effects of covering an instrument with a thin scale of iron, which is the practical result of using a dip of this class, but the present status of this dip is as follows: Some seven years since Heller & Brightly, instrument-makers of Philadelphia, substituted for this iron

the more costly platinum dip (a gallon of the iron dip costs twenty cents to manufacture; a gallon of the platinum \$5.00). Since then almost all the other makers have also adopted this platinum. We regret, however, to say that we have seen within the last six months field-instruments that had been made in New York city, New York State, Boston and Chicago which were darkened or bronzed in this manner; those makers who still adhere to this reprehensible practice do so on account of its cheapness, and also probably from ignorance of its bad effects. This "iron dip" bronzing can readily be detected by the stove-blackening lustre that it imparts to the article bronzed, but the surveyor, on purchasing an instrument from any maker, should insist (and make it part of his contract) that this iron dip shall not be used in the bronzing of it.

#### THE PRECISE MEASUREMENTS OF THE CENTENNIAL BUILDINGS AND OF THE NEW YORK ELEVATED RAILWAY.—*Engineering Review, May 18, 1878.*

The completion of the Elevated Railway in this city will, we hope, solve the question of "rapid transit." \* \* At the very outset one of the perplexing questions was to so arrange that all the material, that was being made hundreds of miles from its final resting-place, should fit precisely together after being brought to the grounds and placed on the piers that were already in place. After considering and rejecting the various merits of chains, steel tapes, stadia measurements, etc., the chief engineer, after consulting with Messrs. Heller & Brightly (who furnished the Transits, Levels, and other field-instruments for the railway), decided upon wooden rods 25 feet long, such as had been designed by Messrs. H. & B. for the Centennial Buildings. The above trouble is not an uncommon one in structures of large extent and having a multiplicity of details, and the more especially since the introduction of the modern practice of having all the material made at places distant from the structure, and of such refractory materials as iron and steel, as these cannot easily be altered. The engineers (Petit & Schwarzmann) in charge of the large Centennial Buildings, such as the Main Exhibition, Horticultural, Agricultural and Machinery Halls, also found that chains, tapes, etc., could not be absolutely relied on for their close measurements, and a substitute had to be found. Messrs. Heller & Brightly (the makers of all the field-instruments for the Centennial engineers) designed a rod of rafted white pine 25 feet long, trussed and braced in such a manner that, even if supported only at the ends, no sag of any amount, either vertical or horizontal, should be perceptible. Levels were placed at each end, and the whole rod was easily carried by one man. This rod proved so satisfactory in the construction of the Centennial Buildings that all the principal measures were given by it. As mentioned above, this same pattern of rod was used on the Elevated Railway of this city, and, in the words of the chief engineer, "gave entire satisfaction in every respect."

#### TESTS OF FIELD INSTRUMENTS AT THE CENTENNIAL GROUNDS—SEVERE TESTS FOR TELESCOPES.—*Railway Journal, January 3, 1878.*

A severe test of Engineers' Transit instruments was made a few days since at the Centennial grounds. \* \* \* \* On the following test, out of twenty new Transits of different makes that were tried, all failed, with one exception. The test was this: The Transit was carefully leveled and plumbed over a point, and from this point, without moving any part of the instrument (except the object-glass slide of the telescope for focussing), new points (stations) were established at every 50 feet up to 800 feet. This was done by measuring off 50 feet continuously, and carefully marking at these places where the intersection of the cross-wires cut. These points were supposed to be all in one straight line. The Transit was then carried the 800 feet to the opposite end of this line, carefully plumbed over the last point (station), and the telescope cross-wires made to cut the first point. The telescope object-glass slide was then moved so that each of the thirty-nine points previously established was focussed; and if the instrument was correctly made, the cross-wires of the telescope should have cut these thirty-nine points, but in only one make of instrument (Heller & Brightly) was this the case, as the cross-wires of all the other instruments struck to the right or left. This is a most severe test of a telescope—in fact, so severe that one manufacturer present asserted that no instrument could perform it. There were some grounds for this assertion; for if the slides of a telescope be made so that they are not projected in an absolutely straight line (or, in other words, that the "line of collimation" for long and short distances is not absolutely the same), the object-glass perfectly centred, and the instrument in perfect adjustment, it is not possible to perform the above feat. In some of the telescopes tested, the telescope-slides slid in and out in such a curve that the feat of "shooting around a corner" did not seem to be an impossibility to them.



INTERNATIONAL  
**EXHIBITION,**  
PHILADA.,  
**1876.**



PHILADELPHIA, November 7, 1876.

**REPORT ON AWARDS.**

*Product.*—**SURVEYING AND ENGINEERING INSTRUMENTS.**

*Name and Address of Exhibitor.*—**HELLER & BRIGHTLY, Philadelphia.**

*The undersigned (judges on instruments of precision), having examined the products herein described, respectfully recommend the same to the United States Centennial Commission for Award —. This firm has lately become distinguished by improvements on the customary methods of constructing Surveying Instruments \* \* \* improved details—and by the construction of Plane Tables of superior quality.*

**PROF. J. E. HILGARD,**  
Supt. U. S. Coast Survey, Washington, D. C.

**PROF. F. A. P. BARNARD, LL.D.,**  
Columbia College, N. Y.

**PROF. P. F. KUPKA,**  
Austria.

**GEN. HENRY K. OLIVER,**  
Salem, Massachusetts.

**GEO. F. BRISTOW,**  
New York.

**PROF. JOSEPH HENRY, LL.D.,**  
Smithsonian Institute, Washington, D. C.

**PROF. JAMES C. WATSON,**  
Univ. of Michigan, Ann Arbor, Mich.

**PROF. JUL. SCHIEDMAYER,**  
Germany.

**PROF. E. LEVASSEUR,**  
France.

**PROF. EDW. FAVRE PERRET,**  
Switzerland.

Given by authority of the U. S. Centennial Commission.

**A. T. GOSHORN, Director-General.**

**J. L. CAMPBELL,**  
*Secretary.*

**J. R. HAWLEY,**  
*President.*

.

In  
 the  
 by  
 lon  
 pal-  
 ion  
 icee  
 374.  
  
 be  
 re at  
 and  
 nap,  
 n.  
 New  
 term  
 end  
  
 and  
 edic  
 on to  
 2<sup>nd</sup> of  
 18  
 inted  
 s line  
 y, Inc  
 this  
 ly ex-  
  
 w 11-73  
 w 90.46  
 w 89.71  
  
 w 102.30  
 w 79.92  
  
 w 59.01

(DECLINATION OF THE MAGNETIC NEEDLE.) **LINES**

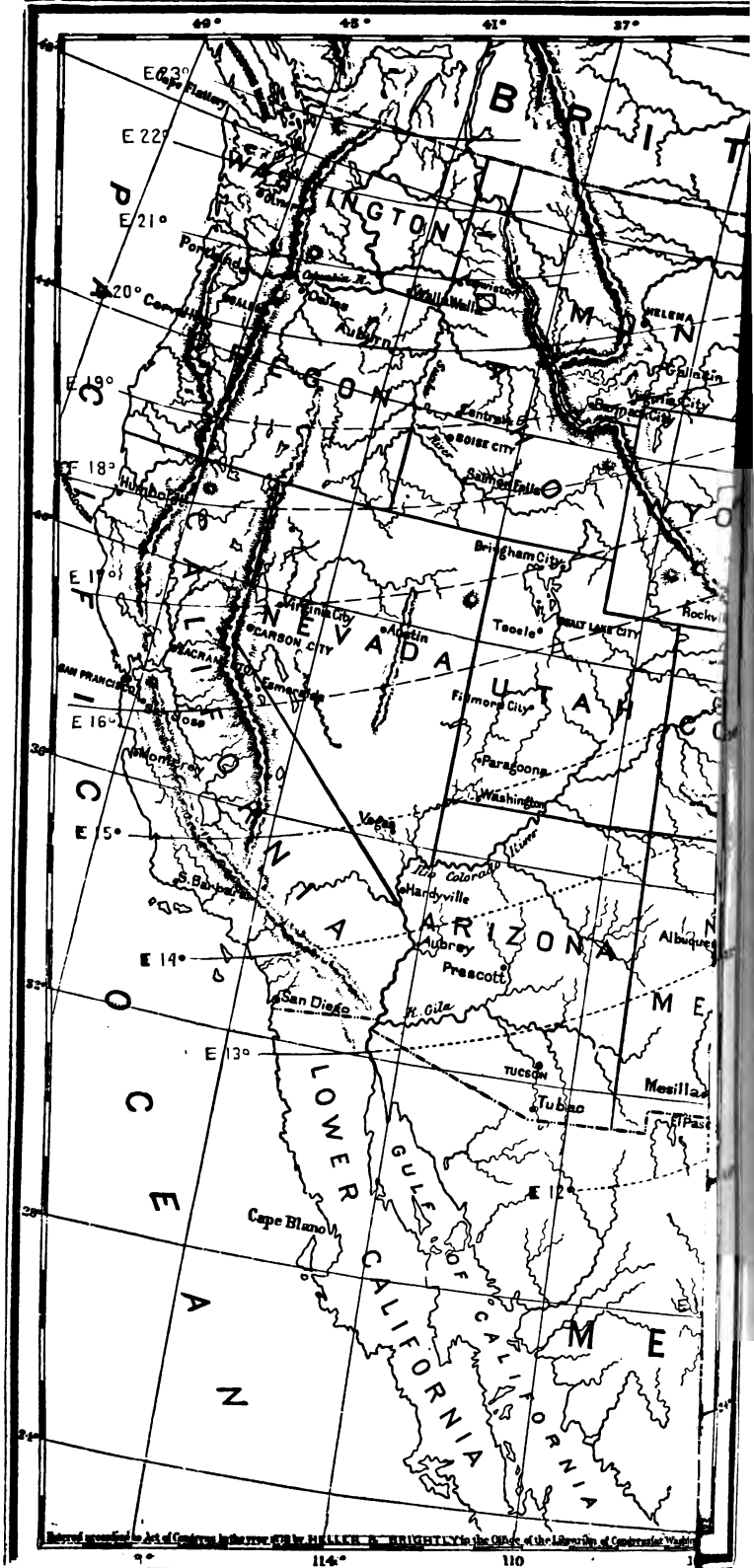

an  
ma  
for  
im  
veg  
str  
PRO  
S  
PRO  
PRO  
GEN  
GEO  
G

Printed under the Act of Congress, September 28, 1876, by HILLIER & BRIGHTELY in the Office of the Librarian of Congress, Washington, D.C.





(DECLINATION OF THE MAGNETIC NEEDLE.) **LINES 870.**

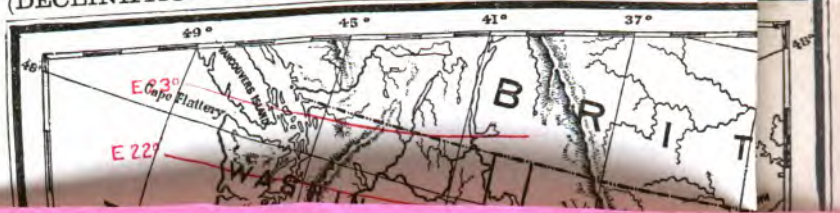

[A large, solid pink rectangular area covers the central portion of the page, completely obscuring any text or graphics that might have been present underneath.]

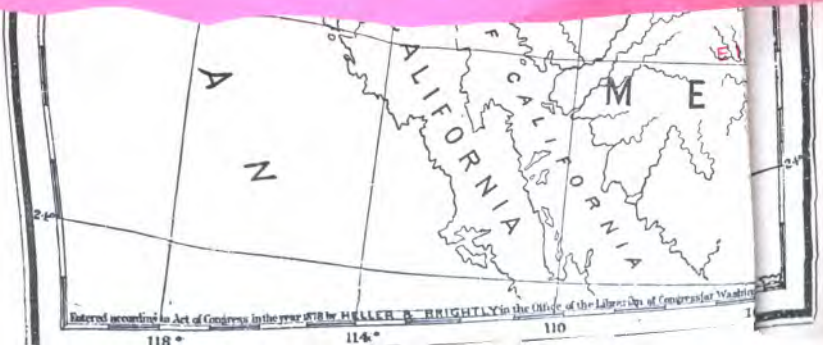

Entered according to Act of Congress in the year 1878 by HALLER B. BRIGHTLY in the Office of the Librarian of Congress at Washington



VARIATION TABLES.

	1870.	1880.	1891.	1892.	1893.	1894.	1895.	1896.	1897.	1898.
Erie, Pa.....										
Woodstock, Va.....	W 2° 27'	W 2° 31'	W 2° 35'	W 2° 40'	W 2° 46'	W 2° 48'	W 2° 54'	W 2° 55'	W 2° 59'	W 2° 54'
Petersburg, Va.....										
Cape Hatteras.....										
(Cleveland.....										
Wilmington, N. C.....	W 1° 01'	W 1° 05'	W 1° 07'	W 1° 09'	W 1° 12'	W 1° 15'	W 1° 16'	W 1° 20'	W 1° 21'	W 1° 27'
Raleigh, N. C.....										
Weston, Pa.....										
Detroit, Mich.....										
Jackson, O.....	E 0° 16'	E 0° 18'	W 0° 17'	W 0° 22'	W 0° 27'	W 0° 32'	W 0° 36'	W 0° 41'	W 0° 46'	W 0° 50'
Rutherfordton, N. C.....										
New York, N. Y.....										
Kingston, Can.....										
Sackett's Har., N. Y.....	W 7° 31'	W 7° 34'	W 7° 39'	W 8° 04'	W 8° 12'	W 8° 17'	W 8° 25'	W 8° 29'	W 8° 34'	W 8° 39'
Rome, N. Y.....										
Brooklyn, N. Y.....										
Jersey City, N. J.....										
Philadelphia, Pa.....										
Camden, N. J.....	W 6° 67'	W 6° 76'	W 6° 84'	W 6° 92'	W 7° 00'	W 7° 08'	W 7° 16'	W 7° 24'	W 7° 35'	W 7° 39'
Owego, N. Y.....										
Washington, D. C.....	W 3° 24'	W 3° 26'	W 3° 29'	W 3° 32'	W 3° 35'	W 3° 38'	W 3° 41'	W 3° 44'	W 3° 46'	W 3° 45'
Cape Henry.....	W 3° 43'	W 3° 50'	W 3° 59'	W 3° 68'	W 3° 77'	W 3° 84'	W 3° 90'	W 3° 97'	W 4° 05'	W 4° 12'
Charleston.....										
Toledo, O.....										
Columbus, O.....										
Portsmouth, O.....	E 0° 66'	E 0° 62'	E 0° 60'	E 0° 57'	E 0° 54'	E 0° 52'	E 0° 50'	E 0° 48'	E 0° 46'	E 0° 44'
Ironton, O.....										
Charlotte, N. C.....										
Monks, S. C.....										
Savannah, Ga.....										
Grand Rapids, Mich.....										
Decatur, Ind.....	E 1° 94'	E 1° 89'	E 1° 83'	E 1° 77'	E 1° 71'	E 1° 66'	E 1° 60'	E 1° 55'	E 1° 50'	E 1° 46'
Hamilton, O.....										
Aiken, S. C.....										
Key West.....	E 3° 72'	E 3° 65'	E 3° 60'	E 3° 55'	E 3° 50'	E 3° 45'	E 3° 40'	E 3° 34'	E 3° 28'	E 3° 21'
Havana.....	E 4° 32'	E 4° 31'	E 4° 77'	E 4° 74'	E 4° 71'	E 4° 68'	E 4° 64'	E 4° 61'	E 4° 58'	E 4° 55'
Kingston, Jam.....	E 3° 19'	E 3° 16'	E 3° 13'	E 3° 11'	E 3° 09'	E 3° 06'	E 3° 03'	E 3° 01'	E 2° 99'	E 2° 96'
New Orleans, La.....										
Jackson, Miss.....	E 6° 67'	E 6° 62'	E 6° 56'	E 6° 49'	E 6° 43'	E 6° 38'	E 6° 33'	E 6° 26'	E 6° 20'	E 6° 13'
Carlinville, Ill.....										
Quincy, Wis.....										
Vera Cruz.....	E 6° 59'	E 6° 48'	E 6° 38'	E 6° 28'	E 6° 18'	E 6° 08'	E 5° 97'	E 5° 87'	E 5° 76'	E 5° 66'
Mexico, Mex.....	E 7° 52'	E 7° 46'	E 7° 40'	E 7° 34'	E 7° 26'	E 7° 19'	E 7° 13'	E 7° 06'	E 6° 98'	E 6° 91'
Acapulco.....	E 7° 58'	E 7° 51'	E 7° 45'	E 7° 38'	E 7° 31'	E 7° 25'	E 7° 18'	E 7° 10'	E 7° 02'	E 6° 96'
Panama.....	E 5° 72'	E 5° 70'	E 5° 66'	E 5° 62'	E 5° 59'	E 5° 56'	E 5° 53'	E 5° 50'	E 5° 47'	E 5° 44'
San Blas.....	E 8° 50'	E 8° 47'	E 8° 44'	E 8° 41'	E 8° 38'	E 8° 36'	E 8° 31'	E 8° 27'	E 8° 23'	E 8° 19'
San Diego.....	E 13° 47'	E 13° 50'	E 13° 53'	E 13° 55'	E 13° 57'	E 13° 59'	E 13° 62'	E 13° 65'	E 13° 68'	E 13° 71'
Monterey, Cal.....	E 16° 05'	E 16° 08'	E 16° 10'	E 16° 13'	E 16° 15'	E 16° 17'	E 16° 18'	E 16° 19'	E 16° 21'	E 16° 23'
San Francisco, Cal.....	E 16° 50'	E 16° 52'	E 16° 53'	E 16° 54'	E 16° 55'	E 16° 56'	E 16° 57'	E 16° 58'	E 16° 58'	E 16° 59'
Cape Disappointment.....	E 21° 94'	E 22° 00'	E 22° 06'	E 22° 13'	E 22° 19'	E 22° 23'	E 22° 26'	E 22° 29'	E 22° 34'	E 22° 38'
Sitka, Alaska.....	E 28° 55'	E 28° 50'	E 28° 45'	E 28° 40'	E 28° 35'	E 28° 29'	E 28° 23'	E 28° 17'	E 28° 11'	E 28° 06'

The best practical method of determining precisely the true meridian of a place is by observing the North Star (Polaris); when this star is at its greatest distance from the meridian east or west, it is said to be at its greatest eastern or western elongation. The following Tables show the times of its eastern and western elongations. The eastern elongations are put down from the beginning of April to the end of September, and the western from the beginning of October to the end of March.

The western elongations in the first case, and the eastern in the second, occurring in the day-time, cannot be used. Some of the others put down in the table are also invisible, occurring in the evening before it is dark, or after daylight in the morning. In such case (if it be necessary to determine the meridian at that particular season of the year) let 5 hours 59 minutes be added to or subtracted from the time of greatest eastern or western elongation, and the observation made at night when the star is on the meridian.

**TIME OF ELONGATION OF THE NORTH STAR (Polaris, *A Ursæ Min.*).**

April 1, 1883, to April 1, 1884.

Computed for North Latitude 38°, and which will serve for all Latitudes from 26° to 50° North, and for all Dates from April, 1878, to April, 1888, with an Error of less than five minutes.

The times are reckoned from noon, astronomical time. An astronomical day commences at noon, and is reckoned from one to twenty-four hours successively; the civil day commences at the

VARIATION TABLES.

preceding midnight, and is reckoned from twelve hours twice in a single day; therefore the last twelve hours of the civil day correspond to the first twelve hours of the astronomical day.

(Table prepared (1878) at the United States Coast Survey Office by direction of Hon. C. P. Paterson, Supt. U. S. C. S.)

EASTERN ELONGATIONS.

Day.	April.		May.		June.		July.		August.		September.	
	A. m.	P. M.	A. m.	P. M.	A. m.	P. M.	A. m.	P. M.	A. m.	P. M.	A. m.	P. M.
1.....	18 37	16 39	14 37	12 39	10 37	8 36	18 14	16 16	14 14	12 16	10 14	8 12
7.....	17 50	15 52	13 50	11 52	9 50	7 48	17 26	15 28	13 26	11 29	9 27	7 25
13.....	17 03	15 05	13 03	11 05	9 03	7 01						

WESTERN ELONGATIONS.

Day.	October.		November.		December.		January.		February.		March.	
	A. m.	P. M.	A. m.	P. M.	A. m.	P. M.	A. m.	P. M.	A. m.	P. M.	A. m.	P. M.
1.....	18 27	16 25	14 28	12 26	10 24	8 30	18 04	16 02	14 04	12 02	10 00	8 06
7.....	17 40	15 38	13 40	11 39	9 35	7 43	17 17	15 15	13 17	11 15	9 13	7 19
13.....	16 53	14 51	12 53	10 51	8 49	6 55						

THE DAILY VARIATION OF THE MAGNETIC NEEDLE.

It has been found that at about the time of sunrise the north end of the needle has a slow motion toward the east which soon ceases. The needle is then said to be at its eastern elongation; its north end then begins a retrograde motion toward the west, and at about one o'clock in the afternoon reaches the point at which it is said to be at its western elongation, after which it again turns back toward the east.

The times at which the needle reaches its eastern and western elongations vary with the seasons of the year (with the sun's declination), happening a little earlier in summer than in winter.

The angular range between the eastern and western elongations varies also with the season of the year.

The average position of the needle for the day is called the *mean magnetic meridian*.

At about six o'clock in the evening (and for about an hour before and after), throughout the year, the position of the needle coincides very nearly with the mean magnetic meridian, and this, therefore, is the time most favorable for making observations to obtain at once the mean variation.

For reducing the direction of the needle observed at other hours to the mean magnetic meridian, the following Table is furnished. It gives to the nearest minute the variations of the needle from its average position during the day, for each hour in the day for the four seasons of the year.

TABLE FOR REDUCING THE OBSERVED DAILY VARIATION TO THE MEAN VARIATION OF THE DAY.

(Table prepared (1878) at the United States Coast Survey Office by direction of Hon. C. P. Paterson, Supt. U. S. C. S.)

Hour.....	The needle points east of the mean magnetic meridian—					The needle points west of the mean magnetic meridian—							
	A.M.	A.M.	A.M.	A.M.	A.M.	A.M.	Noon.	P.M.	P.M.	P.M.	P.M.	P.M.	P.M.
	6	7	8	9	10	11	Noon.	1	2	3	4	5	6
Spring.....	3	4	4	3	1	1	4	5	4	3	2	1	1
Summer.....	4	5	5	4	1	2	4	6	5	4	3	2	1
Autumn.....	2	3	3	2	0	2	3	4	3	2	1	1	0
Winter.....	1	1	2	2	1	0	2	3	3	2	1	1	0



Unalaska Island.	18.02
Sitka, Alaska.	26.16
Cape Disappointment, Wash.	18.0

By an inspection of the Map and of the Tables for the next ten years, and with the aid of a good map of his own State, the surveyor in any part of the country, at any time, will have no difficulty in getting a very close approximation of the variation of his own individual section.

If any place is so situated as to be between the variation-lines on the map, by dividing the space between the lines with a pair of dividers into ten parts, each of these will represent six minutes (the lines being one degree apart). Recollect, however, that, the Map being for the year 1870, the variation has changed slightly since then. An inspection of the Table accompanying the Map will, however, give the variation for the year sought for, under its appropriate date. As a matter of interest, there is placed on the map, the 0° (or "line of no variation") as it was in 1801 and 1850; from this it will be seen that the variation is slowly traveling westward—in the Middle States at an average rate of three or four minutes a year. (See "Table of the Yearly Change in the Magnetic Variation in the United States.")

For retracing old lines, the two Tables—i. e., the "Table of Yearly Change of Variation" and the "Changes for Every Ten Years from 1640 to 1880"—will be found specially useful.

The three Tables—namely, "The Changes in Variation for Every Ten Years," the "Elongations" and "Azimuths of the North Star"—we only publish because *in no work published are they correctly given*; while the two Tables, the "Daily Change in the Variation of the Needle," and the "Yearly Change in the Variation," are fresh Tables never heretofore published. These five Tables have been just (1878) prepared at the United States Coast Survey Office (to which we are indebted for advance copies) for the use of the Surveyors-General of the United States.

To those who wish to study more thoroughly the subject of magnetic variation, the modes by which the true variation may be ascertained, etc., we would recommend the work of Professor Stone on "Magnetic Variation in America," just out of press and for sale by us. A description of this work, table of contents, etc., will be found at the end of this pamphlet.

[OVER.]

Year (Jan. 1).	1640	1700	1800	1880
New York, N. Y.	16.52	16.86	16.11	16.86





CHANGES IN THE MAGNETIC VARIATION FROM 1840 TO 1880.—Continued.

Year (Jan. 1)	New York, N. Y.	Hatborough, Pa.	Philadelphia, Pa.	Washington, D. C.	Cape Henry, Va.	Charleston, S. C.	Savannah, Ga.	Key West, Fla.	Havana, Cuba.	Kingston, Jamaica.	New Orleans, La.	Vera Cruz, Mexico.	Mexico, Mexico.	Acapulco, Mexico.	Panama, New Granada.	San Blas, Mexico.	San Diego, Cal.	Monterey, Cal.	San Francisco, Cal.	Cape Disappointment, Wash.	Sitka, Alaska.	Utahaska Island.
1840	+7.54	+6.8	+6.78	+3.81	+5.00	+1.89	+1.89	+3.65	-5.1	-3.4	-6.62	-7.15	-7.46	-7.5	-5.79	-7.88	-11.0	-11.4	-12.9	-18.0	-26.16	-18.92
50	+7.54	+6.8	+6.78	+3.81	+5.00	+1.89	+1.89	+3.65	-5.1	-3.4	-6.62	-7.15	-7.46	-7.5	-5.79	-7.88	-11.0	-11.4	-12.9	-18.0	-26.16	-18.92
60	+7.54	+6.8	+6.78	+3.81	+5.00	+1.89	+1.89	+3.65	-5.1	-3.4	-6.62	-7.15	-7.46	-7.5	-5.79	-7.88	-11.0	-11.4	-12.9	-18.0	-26.16	-18.92
70	+7.54	+6.8	+6.78	+3.81	+5.00	+1.89	+1.89	+3.65	-5.1	-3.4	-6.62	-7.15	-7.46	-7.5	-5.79	-7.88	-11.0	-11.4	-12.9	-18.0	-26.16	-18.92
80	+7.54	+6.8	+6.78	+3.81	+5.00	+1.89	+1.89	+3.65	-5.1	-3.4	-6.62	-7.15	-7.46	-7.5	-5.79	-7.88	-11.0	-11.4	-12.9	-18.0	-26.16	-18.92
90	+7.54	+6.8	+6.78	+3.81	+5.00	+1.89	+1.89	+3.65	-5.1	-3.4	-6.62	-7.15	-7.46	-7.5	-5.79	-7.88	-11.0	-11.4	-12.9	-18.0	-26.16	-18.92
100	+7.54	+6.8	+6.78	+3.81	+5.00	+1.89	+1.89	+3.65	-5.1	-3.4	-6.62	-7.15	-7.46	-7.5	-5.79	-7.88	-11.0	-11.4	-12.9	-18.0	-26.16	-18.92
110	+7.54	+6.8	+6.78	+3.81	+5.00	+1.89	+1.89	+3.65	-5.1	-3.4	-6.62	-7.15	-7.46	-7.5	-5.79	-7.88	-11.0	-11.4	-12.9	-18.0	-26.16	-18.92
120	+7.54	+6.8	+6.78	+3.81	+5.00	+1.89	+1.89	+3.65	-5.1	-3.4	-6.62	-7.15	-7.46	-7.5	-5.79	-7.88	-11.0	-11.4	-12.9	-18.0	-26.16	-18.92
130	+7.54	+6.8	+6.78	+3.81	+5.00	+1.89	+1.89	+3.65	-5.1	-3.4	-6.62	-7.15	-7.46	-7.5	-5.79	-7.88	-11.0	-11.4	-12.9	-18.0	-26.16	-18.92
140	+7.54	+6.8	+6.78	+3.81	+5.00	+1.89	+1.89	+3.65	-5.1	-3.4	-6.62	-7.15	-7.46	-7.5	-5.79	-7.88	-11.0	-11.4	-12.9	-18.0	-26.16	-18.92
150	+7.54	+6.8	+6.78	+3.81	+5.00	+1.89	+1.89	+3.65	-5.1	-3.4	-6.62	-7.15	-7.46	-7.5	-5.79	-7.88	-11.0	-11.4	-12.9	-18.0	-26.16	-18.92
160	+7.54	+6.8	+6.78	+3.81	+5.00	+1.89	+1.89	+3.65	-5.1	-3.4	-6.62	-7.15	-7.46	-7.5	-5.79	-7.88	-11.0	-11.4	-12.9	-18.0	-26.16	-18.92
170	+7.54	+6.8	+6.78	+3.81	+5.00	+1.89	+1.89	+3.65	-5.1	-3.4	-6.62	-7.15	-7.46	-7.5	-5.79	-7.88	-11.0	-11.4	-12.9	-18.0	-26.16	-18.92
180	+7.54	+6.8	+6.78	+3.81	+5.00	+1.89	+1.89	+3.65	-5.1	-3.4	-6.62	-7.15	-7.46	-7.5	-5.79	-7.88	-11.0	-11.4	-12.9	-18.0	-26.16	-18.92
190	+7.54	+6.8	+6.78	+3.81	+5.00	+1.89	+1.89	+3.65	-5.1	-3.4	-6.62	-7.15	-7.46	-7.5	-5.79	-7.88	-11.0	-11.4	-12.9	-18.0	-26.16	-18.92
200	+7.54	+6.8	+6.78	+3.81	+5.00	+1.89	+1.89	+3.65	-5.1	-3.4	-6.62	-7.15	-7.46	-7.5	-5.79	-7.88	-11.0	-11.4	-12.9	-18.0	-26.16	-18.92
210	+7.54	+6.8	+6.78	+3.81	+5.00	+1.89	+1.89	+3.65	-5.1	-3.4	-6.62	-7.15	-7.46	-7.5	-5.79	-7.88	-11.0	-11.4	-12.9	-18.0	-26.16	-18.92
220	+7.54	+6.8	+6.78	+3.81	+5.00	+1.89	+1.89	+3.65	-5.1	-3.4	-6.62	-7.15	-7.46	-7.5	-5.79	-7.88	-11.0	-11.4	-12.9	-18.0	-26.16	-18.92
230	+7.54	+6.8	+6.78	+3.81	+5.00	+1.89	+1.89	+3.65	-5.1	-3.4	-6.62	-7.15	-7.46	-7.5	-5.79	-7.88	-11.0	-11.4	-12.9	-18.0	-26.16	-18.92
240	+7.54	+6.8	+6.78	+3.81	+5.00	+1.89	+1.89	+3.65	-5.1	-3.4	-6.62	-7.15	-7.46	-7.5	-5.79	-7.88	-11.0	-11.4	-12.9	-18.0	-26.16	-18.92
250	+7.54	+6.8	+6.78	+3.81	+5.00	+1.89	+1.89	+3.65	-5.1	-3.4	-6.62	-7.15	-7.46	-7.5	-5.79	-7.88	-11.0	-11.4	-12.9	-18.0	-26.16	-18.92
260	+7.54	+6.8	+6.78	+3.81	+5.00	+1.89	+1.89	+3.65	-5.1	-3.4	-6.62	-7.15	-7.46	-7.5	-5.79	-7.88	-11.0	-11.4	-12.9	-18.0	-26.16	-18.92
270	+7.54	+6.8	+6.78	+3.81	+5.00	+1.89	+1.89	+3.65	-5.1	-3.4	-6.62	-7.15	-7.46	-7.5	-5.79	-7.88	-11.0	-11.4	-12.9	-18.0	-26.16	-18.92
280	+7.54	+6.8	+6.78	+3.81	+5.00	+1.89	+1.89	+3.65	-5.1	-3.4	-6.62	-7.15	-7.46	-7.5	-5.79	-7.88	-11.0	-11.4	-12.9	-18.0	-26.16	-18.92
290	+7.54	+6.8	+6.78	+3.81	+5.00	+1.89	+1.89	+3.65	-5.1	-3.4	-6.62	-7.15	-7.46	-7.5	-5.79	-7.88	-11.0	-11.4	-12.9	-18.0	-26.16	-18.92
300	+7.54	+6.8	+6.78	+3.81	+5.00	+1.89	+1.89	+3.65	-5.1	-3.4	-6.62	-7.15	-7.46	-7.5	-5.79	-7.88	-11.0	-11.4	-12.9	-18.0	-26.16	-18.92



VARIATION TABLES.

The following Table exhibits the angle which the meridian plane makes with the vertical plane passing through the North Star (Polaris) when at its greatest eastern or western elongation. Such angle is called the azimuth—the mean angle only is put down, being calculated for the first of July of each year.

**AZIMUTH OF NORTH STAR (Polaris, *A Ursæ Min.*) AT ELONGATION, 1878 to 1888. (Latitude, 26° to 50° North.)**

(Table prepared (1878) at the United States Coast Survey Office by direction of Hon. C. P. Paterson, Supt. U. S. C. S.)

	26°	28°	30°	32°	34°	36°	38°	40°	42°	44°	46°	48°	50°
	° /	° /	° /	° /	° /	° /	° /	° /	° /	° /	° /	° /	° /
1878.....	1 29½	1 31½	1 33	1 35	1 37½	1 39½	1 42½	1 45½	1 48½	1 52	1 56	2 00½	2 05½
1879.....	29½	30½	32½	34½	36½	38½	41½	44½	48	51½	55½	2 00	04½
1880.....	29	30½	32½	34½	36½	38½	41½	44½	47½	51	55	1 59½	04½
1881.....	28½	30½	32	33½	36	38½	41	44	47	50½	54½	59	03½
1882.....	28½	29½	31½	33½	35½	38	40½	43½	46½	50½	54½	58½	03½
1883.....	28	29½	31½	33	35½	37½	40½	43	46½	49½	53½	58	02½
1884.....	27½	29	30½	32½	35	37½	39½	42½	45½	49½	53½	57½	02½
1885.....	27½	28½	30½	32½	34½	36½	39½	42½	45½	49	52½	57	02
1886.....	26½	28½	30	32	34	36½	39	41½	45	48½	52½	56½	01½
1887.....	26½	28	29½	31½	33½	36	38½	41½	44½	48	51½	56½	01
1888.....	26	27½	29½	31½	33½	35½	38½	41	44	47½	51½	55½	00½

The following Table of the present (1878) yearly change in the magnetic variation gives a close approximation of the amount of change along our immediate sea-coast. For the interior States the information is very scanty, and therefore less trustworthy. The yearly change is expressed in minutes of arc. A + sign indicates increase of westerly or decrease of easterly variation. A — sign indicates an increase of easterly variation.

**YEARLY (Secular) CHANGE IN THE MAGNETIC VARIATION OF THE COMPASS NEEDLE.**

(Table prepared (1878) at the United States Coast Survey Office by direction of Hon. C. P. Paterson, Supt. U. S. C. S.)

Locality.	Yearly change.
Maine, coast of.....	+2
Maine, interior.....	+3
New Hampshire.....	+3½
Vermont.....	+5½
Massachusetts, eastern part.....	+2½
Massachusetts, western part.....	+3 to 4
Rhode Island and Connecticut.....	+3½
New York, Long Island.....	+3
New York, northern and western part.....	+4½
New Jersey.....	+3
Pennsylvania.....	+3½
Ohio.....	+2½
Tennessee, eastern part.....	+2½
Tennessee, western part.....	+2
Missouri.....	+2
Delaware, Maryland and Virginia.....	+3
West Virginia.....	+3½
North Carolina, South Carolina and Georgia.....	+3½
Florida, northern part.....	+3½
Florida, southern part.....	+3
Alabama and Mississippi, Gulf coast of.....	+3
Louisiana, eastern part.....	+2½
Louisiana, western coast.....	+2
Texas, coast of.....	+1
Texas, southwestern part.....	} 0 (probably.)
New Mexico and Southwestern Arizona.....	
California, coast of.....	-1½
Oregon, coast of.....	-2 to 2½
Washington Territory, coast of.....	-2½ to 3

# REMARKS

ON

## ENGINEERS' SURVEYING INSTRUMENTS.

We are often applied to by Engineers respecting the methods to be employed in testing the accuracy of the various parts of **Engineers' Instruments**, the errors to which they are liable, and the means of correction. (These queries are, however, mostly from those just commencing practice, their elder brethren, as a general rule, knowing how to make an instrument "prove itself.")

In the following articles we have endeavored to comply with these requests. It would surprise those who think "one instrument as good as another" to be informed that in perhaps no other branch of mechanism are palpable "**errors of omission and commission**" more common than in ours—surveys extending over months of time have been rendered almost useless from "instrumental error," and a considerable portion of the business of our courts of law is caused directly and indirectly by imperfections of instruments.

The recent case of the **City of Burlington, N. J.**, is in point.\* Here the courts were so frequently annoyed by land suits from defective surveys that the Legislature of the State was compelled to pass a law that an entire re-survey, by a competent person and first-class instruments, should be made. A law requiring every instrument to be tested and proved by a competent person (not necessarily a manufacturer) would have a tendency to weed out instruments which, like "Peter Pindar's" razors, are made, "not to use, but to sell."

We will not stop to speak of the ordinary adjustments of instruments, as they are found in every elementary work pertaining to Civil Engineering—if a knowledge of these, however, be required, "Trautwine's Engineers' Pocket-book" will give them in detail. We will mention in their order, the Transit, Level, Telescope, Compass, Solar Compass and Plane Table.

### THE TRANSIT.

A first-class Transit Instrument should possess the following qualities. In the first place, *all its graduations should be on silver plate (instead of on the plain brass and silver washed, as is usual)*—all astronomical instruments are done in this way, as a smoother, truer graduation can be had. The divisions of the horizontal limb should be **truly graduated and centred** (*i. e.*, the graduations should be *precisely* the same distance from each other—the centre of the graduations and the centre of revolution should be *precisely* at the same point). The instrument should always have **two opposite verniers to the horizontal limb** (and these verniers should be **equally spaced**). In astronomical instruments more than two verniers are absolutely necessary, but we are now speaking of Engineering Instruments.

The interior of the glass level tubes should be **ground**, in order that their bubbles may act correctly. The **needle** should be sensitive enough to coincide with the verniers of the horizontal limb without disagreeing more than 3'. The centre upon which the **vernier plate** turns, and the common centre upon which the entire instrument revolves (we are now having one of the best class of Transits under consideration—*i. e.*, *one with long compound centres*), should be **concentric with each other**, and the levels, if adjusted to one centre, should reverse upon either one at will. *Both of the centres should be always covered, and not detachable from the main plates.*

The tripod and tripod head should be firm and steady, the **centre of gravity** of the instrument brought as near to the tripod head as possible, and the instrument **not top-heavy**. The tripod should be furnished with an **adjustable tripod head** for precise centring of the instrument (the adjustable tripod head

\* See H. S. Haines' letter, accompanying Franklin Institute Report of Civil Engineers.

is intended for precisely centring the instrument, after approximately setting by the legs in the following manner). First approximate by the legs to within an inch or less, loosen two of the leveling screws, then move the entire instrument until the plummet is precisely centred. While placing the instrument level by means of the leveling screws it is again clamped.

The leveling screws should have deep threads, good milled finger-heads, and be well fitted to their nuts.—The openings and windows in the upper plate for reading the verniers of the horizontal limb should be as wide as possible, to admit light freely upon the verniers and plate, thus facilitating an accurate reading (this single point as a general rule being overlooked). The vertical arc or circle (if one is used) should have a diameter of not less than  $4\frac{1}{2}$  inches, to allow single minutes (at least) to be read easily.

The plates and centres should move smoothly in all temperatures.

The spindle of a turning lathe can never be made precisely round, and of course any article turned in a lathe can only be as true as its spindle. Any work that is required to be precisely round and true, such as the journals of the axes of an Astronomical Transit or its centres, is turned on a lathe in which the spindle remains stationary, and the work revolves between centres.—In order to insure the actual truth of the centres of all of our instruments, they are made by this method (termed turning between "dead centres"), although it has heretofore only been used for astronomers' instruments.

The mechanical construction should be so arranged that all the parts shall as far as possible brace each other. The tangent screws should move smoothly and have no "back lash."

The Telescope should be balanced in its axis. Its length from 10 to 12 inches, to allow of its reversing in its standards, both at eye and object ends; it should have power enough to set an ordinary flagpole at 1000 feet; its object glass slide should move in and out in a perfectly straight line, in order that the line of collimation, when adjusted for a long distance, shall be correct for a short one. (This precaution does not always receive the attention it should, and young Engineers are frequently at a loss to account for discrepancies in their observations which are due to this cause.)

The slide of the object glass should be long enough to be able to focus an object five feet from the instrument. The adjustments of the telescope (and in fact of the whole instrument) should be as few as possible, every part admitting of it to be made as permanent as practicable. One end of the axis of the telescope should be adjustable, so as to make the "line of collimation" revolve truly in a vertical plane; and this adjustment should be provided with a jam nut, in order to fasten it securely after adjustment. The best method of testing this adjustment is by a star as near vertical as the telescope will allow of; if, after careful leveling of the instrument, the telescope cuts this star and its reflection in a basin of quicksilver, it is equivalent to cutting the two ends of a plumb line at least 50 million million miles long.

Having mentioned the traits a good transit should possess, we will pass in review some of the more common defects; and in this connection will take the opportunity of remarking that all the defects we will enumerate are matters of almost every-day observation in establishments that have a large amount of outside repairing to do.

As the Telescope has been termed "the brain; and the graduations the soul of a Transit," we will first take imperfect graduation, as this is the most serious and damaging imperfection, and one of the most difficult to avoid in practice, as any of the following causes may defeat it during the process of construction. Namely—an imperfect graduating engine, defective centring, unstable cutting arrangement; and even if all these be correct, in the very act of graduating the plate may shift on the engine, from change of temperature; or the clamps, metal of the plate, or engine, may expand unequally from the same cause; in fact, the manufacturer, with all the care he may take, is not sure himself whether the process of graduating a plate has proceeded correctly until the graduations themselves are proved by means of its own opposite verniers, and until "testing reversions," for the purpose of proving the centre and graduations, have been

IMPROVED COMPLETE  
"COMBINED TRANSIT AND LEVELING INSTRUMENT,"  
For Civil Engineers and Surveyors.

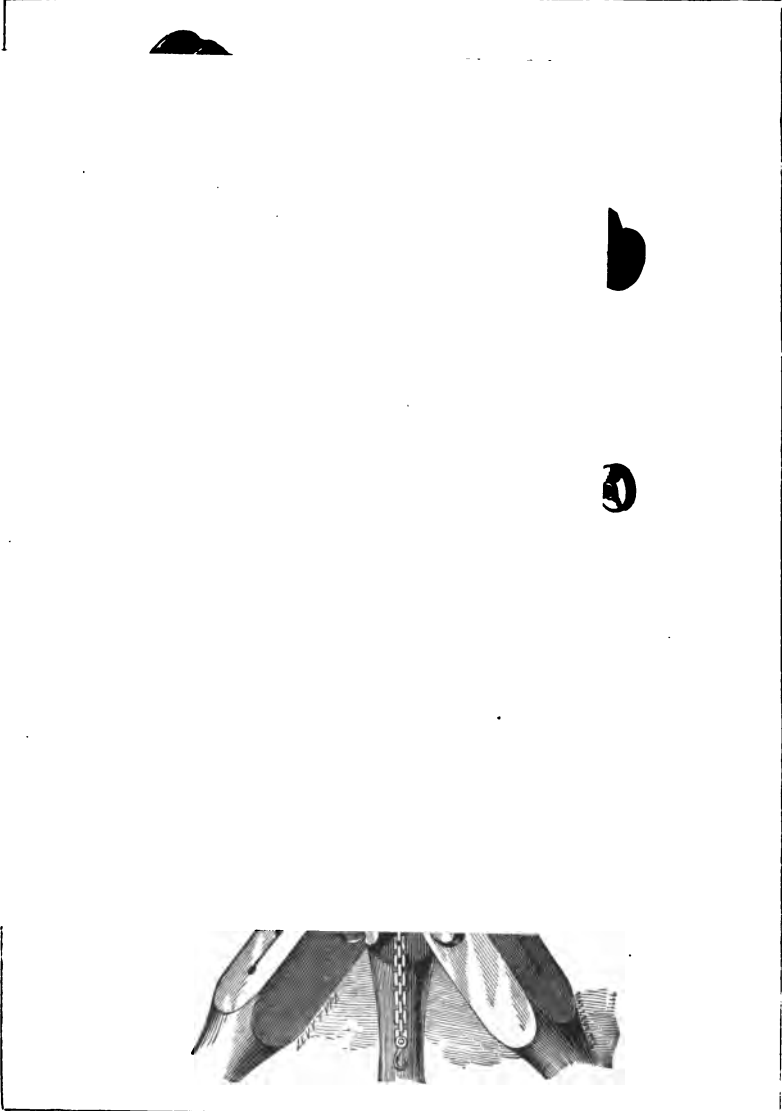

MADE BY  
**HELLER & BRIGHTLY, PHILADELPHIA, PA.**

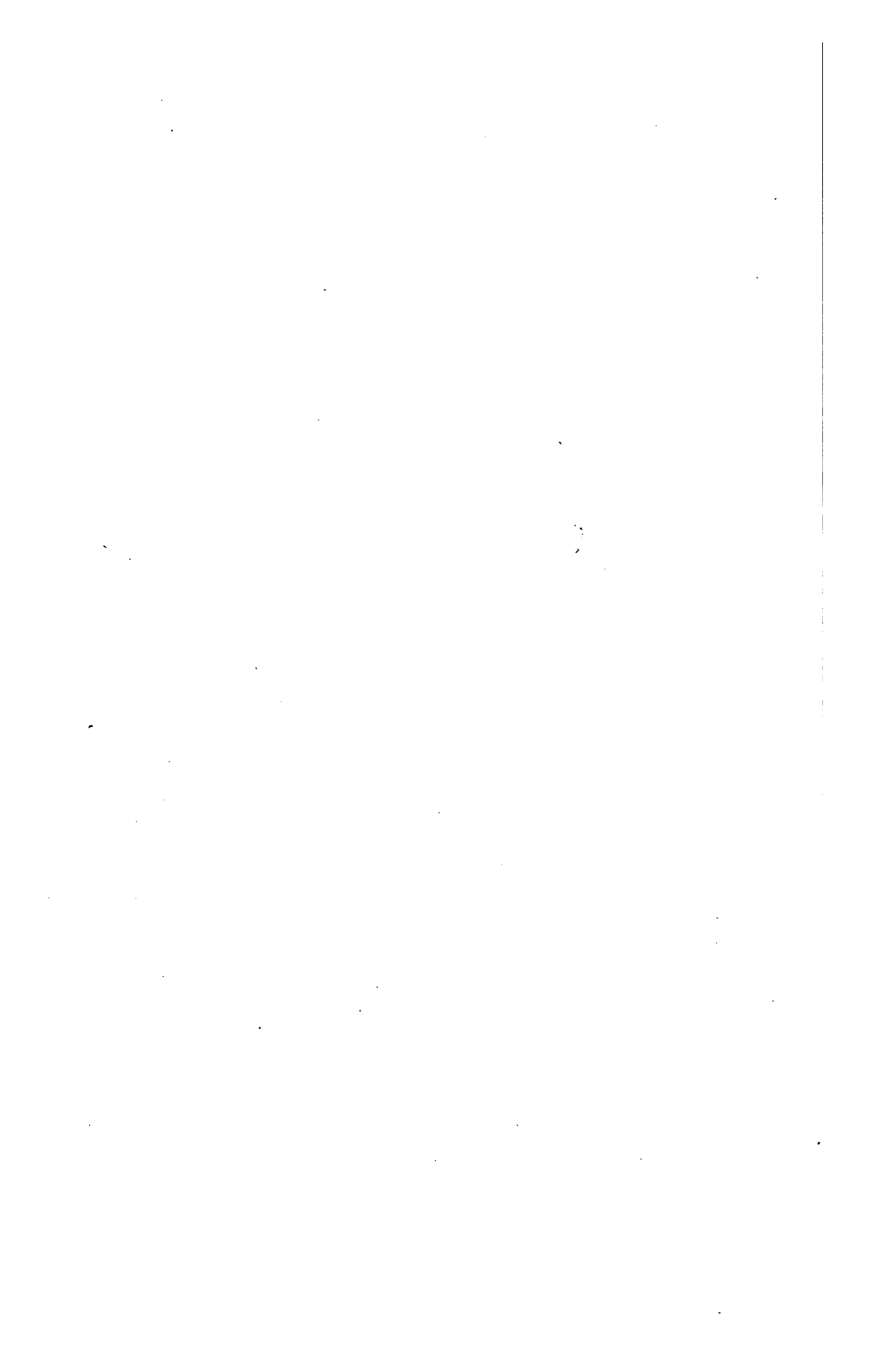



## LATE IMPROVEMENTS

### PEOULIAR TO THE HELLER & BRIGHTLY TRANSIT.

(See Illustration for explanatory letters.)

a.—Dust- and rain-guard to object-slide of telescope.

The object-slides of all telescopes are necessarily exposed to flying dust, grit, etc.; this settles on the slide and is carried into the main tube of the telescope, rapidly wearing the tube and the slide, **destroying both the accurate projection of the object-glass in a straight line and the truth of the line of collimation.** Dampness and rain were also admitted inside the telescope, dimming the glasses and settling on the cross-wires. This arrangement a is a perfect safeguard against all these evils. The parts lettered *f* and *g* are also **dust-guards to the leveling-screws K.**

b.—The vernier-plate tangent-screw. This tangent-screw has also a **dust- and rain-guard.**

(Both the tangent-screw *b* and the one moving the axis of the telescope (seen just below *n*) are provided with an arrangement for taking up "lost motion," or wear in the screw. See pamphlet, page 23, *Report of Comm. of Civ. Eng.*)

c.—Ivory reflectors over the glass windows of the two verniers *p*. (The second vernier *p* and its ivory reflector *c* are on the opposite side of the horizontal plate *P*, between the standard *V*, and of course cannot be shown in the engraving.)

(All engineers must have noticed the **difficulty of reading the verniers *p* on a bright day**, this difficulty being caused by the glare of the silver surface, which renders necessary the shading of the verniers by the hand or a hat. The ivory reflectors *c* remove this annoying glare; they are also inclined at such an angle as to **throw a soft white light** on the divisions. In mine-surveying or night-observations light from a lamp or lantern falling on these reflectors allows the divisions of the horizontal plate and its verniers to be easily seen and read.)

f.—Dust-caps for protecting upper parts of leveling-screws *K* from dust, rain, etc.

g.—Stuffing-boxes for protecting lower parts of leveling-screws *K* from dust, rain, etc.

k.—The lower end of these leveling-screws *K* are so made as to be **perfect balls**, which work and are concealed in a socket *k*.

By this means, while using the leveling-screws *K*, a smooth, equable motion is had **without indenting** the lower parallel plate *S*, on which they rest, and also facilitating the **use of the "plummets shifting-plate" *d*.**

d.—Shifting-plate to tripod-head, for **precisely setting the plummet** of the transit over a point on the ground after **approximately setting** the plummet by means of the **tripod legs**, the plummet being suspended from the centre of the instrument at *J*.

Q.—New form of tripod-leg, in which the wooden leg *Q* incloses the brass cheeks of the tripod-head, the leg being **tightened or loosened** by merely turning the threaded wing-nut *J*. A screw on the end of the through-bolt prevents the wing-nut being screwed too far out and lost.

NOTE.—In the old form of tripod-leg, in which the wood is inclosed by the brass cheeks of the tripod-head, trouble constantly arose, **pieces of paper** or leather being resorted to to take up the shake occasioned by the wood of the legs contracting in dry weather or by wear, and **in damp weather the swelling of the wood** also creating difficulty. In the above new form of tripod-leg all these annoyances are overcome.

It will be noticed that there is a "**sighting-slit**," similar to those in the sights of a Surveyor's Compass, in the **vernier-clamp** of the vertical arc; there is also a similar "**sighting-slit**" in the opposite **clamp *z***. (This slit, however, can be only partially seen in the cut.) The use of this is as follows: When the  $0^{\circ}$  (or zero) of the vernier clamp cuts  $30^{\circ}$  on the vertical arc and the index on the opposite clamp made to cut a line that will be found on the brace of the standard *V*, a **right-angled sight is had through the sighting-slits**. This is convenient for offsetting, right-angles, etc.

D.—Long-bubble tube under the telescope, for leveling, etc.

The graduated vertical arc *s* has two rows of figures—one for **angles of elevation**, the other for **depression**. The telescope can be set **perfectly level** by means of the long-level bubble *D* and the tangent-screw (at *n*) on the standard of the telescope. **If an angle of depression is required to be read**, the vernier-arm is made to touch the screw *t* at the left-hand end of the vertical arc *s*; the zero lines (or  $0^{\circ}$ ) of the vertical arc and the vernier-arm will then agree. **Then clamp the vernier-arm to the axis of the telescope by means of its milled-head screw.** On depressing the telescope the vernier-arm will show the angle passed over. If, after reaching the end of the arc, a greater angle than  $60^{\circ}$  be required, proceed as follows: **Clamp the axis of the telescope by means of the clamp *z*; unclamp the vernier-clamp and move it back until it again touches the screw *t*; loosen the clamp *z* and again move the telescope.** By thus **repeating the angle** the entire circle can be read. It will be observed that by merely unclamping the vernier-clamp and the clamp *z* from the axis of the telescope the telescope can be revolved in any direction, as if it were merely a "plain" Transit.

B.—A ring surrounding the telescope, and carrying four capstan-headed screws, two of them, *p*, being at **top and bottom**, while the other two (of which *t* is one) are at the side and at right angles to *p*; these capstan-headed screws are to be used in adjusting the cross-wires of the telescope to the "**line of collimation**." The small holes around the heads of *p* admit the end of a small steel pin or lever to turn them in case adjustment is necessary. Besides these four capstan-headed screws, there are at the top and bottom of the telescope **two other capstan-headed screws** (one of which is seen beside *p*); these latter are **for adjusting the two slides carrying the stadia wires**. It may be as well to state that, as the slides to which these wires are attached are **moved independently** of the diaphragm carrying the ordinary horizontal and vertical cross-wires, the **stadia-wires** can be at any time adjusted **without fear of disturbing** in the least any of the adjustments of the ordinary cross-wires.

n.—Capstan-headed nuts for adjusting the long-level bubble-tube *D*.

One end of this tube can be **raised or lowered** by means of these nuts *n*, one of which must be loosened before the other is tightened.

E. O.—Telescope.—X.—Axis of telescope. One end of the axis (at *z*) is arranged with an adjustable block moved by a screw; this is for the adjustment of the cross-wires to the tracing of a vertical line.—D.—Brass tube inclosing a sensitive glass level bubble.—L.—Screw for raising or lowering compass-needle.—C.—Compass-box.—z.—Clamp for holding telescope in any required position.—p.—Vernier for reading horizontal limb or circle. This vernier is covered with a glass window. There is a second vernier opposite to this, but it is not shown.—e.—Clamp-screw for binding the two plates together. After such binding the upper or vernier-plate can be **moved very slowly** by means of the **tangent-screw *b***.—y.—Clamp to lower socket.—H.—Clamp-screw to clamp *y*.—G.—Tangent-screws, or set screws to clamp *y*.—S.—Large screw-cap to secure instrument to tripod.—r.—Capstan-headed screws for raising or lowering the two levels *M* in adjusting. The curved piece seen projecting over the level *M* at the front of the compass-plate is intended as a guard to **protect the glass level-bubble** in *M* from accident.

For explanation of other parts of the telescope, tripod, and instrument, see explanatory remarks under head of Leveling Instrument.

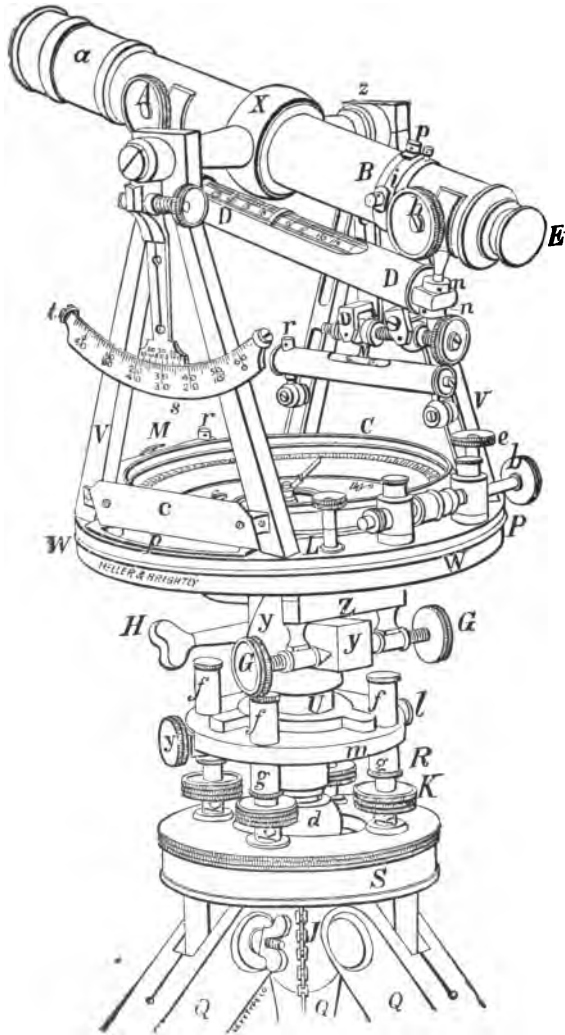



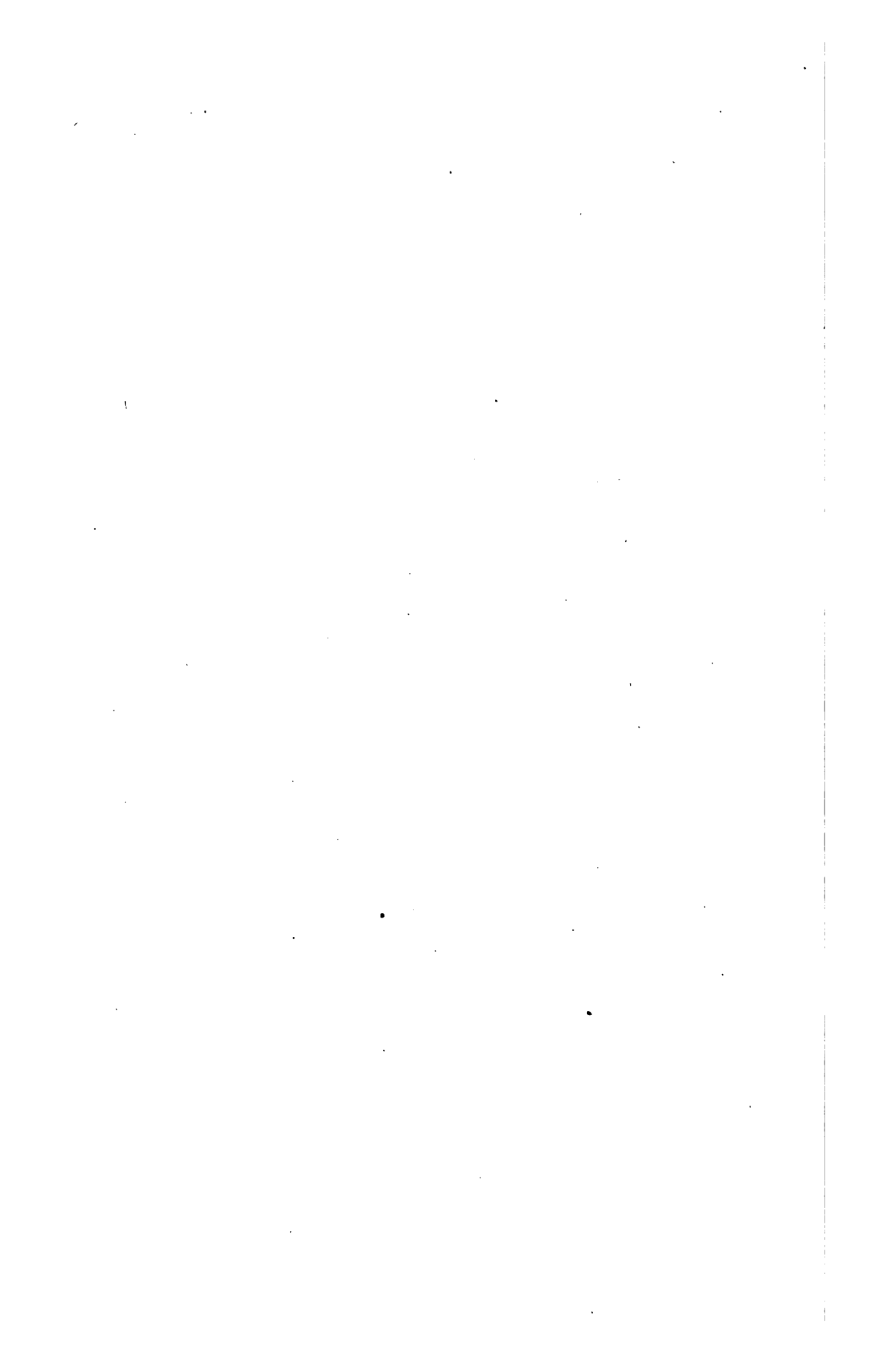

taken on all parts of the circle; the "*fertile principle of reversion*" and its peculiar merit of "doubling the real error, thus making it twice as easy to perceive" here, as in every other adjustment of the instrument, making each part prove itself.

It was mentioned among the points of a good transit that the horizontal limb should have two opposite verniers. Without these even the manufacturer himself cannot (as explained above) be sure of the accuracy of his graduations; however, by taking a mean of two opposite readings, reversing and repeating, an accurate angle can be taken even though there be an imperfect graduation.

One very rare cause of error of observation may be mentioned in speaking of the reading and testing of graduations. We refer to those persons who, probably from some defect of the humors of the eye (not from advancing age), are unable to read a vernier correctly. Extreme cases of this "*personal aberration*" are fortunately rarely met with; the writer in fifteen years' intercourse with hundreds of Engineers has only met with two; in both of these, if a reading was taken and noted by them, the vernier might be shifted two minutes to the right or left, and these parties could perceive no change in the reading,—and in their field operations close readings of graduations had to be taken by assistants. We do not here refer to the "difference of reading" of two persons, which under the term of "*personal equation*" is calculated and allowed for in refined astronomical observations.\*

If the Engineer is satisfied that his graduations are correct, he need read but one of his verniers, rendering the window of the opposite one opaque (to prevent mistake by reading the wrong vernier) by dulling it with oil, or pasting a wafer on it. It is a good method, where two verniers are used, to have some mode of designating them apart; our own mode is to engrave the letter A upon one, B upon the other. The numbering of the degrees may be done in several ways; our own method is to place on both the horizontal limb and needle ring two rows, one behind the other, and each row of a different sized figure, to prevent mistakes; one row in quadrants ( $0^{\circ}$  to  $90^{\circ}$  each way), and the other a continuous one or from  $0^{\circ}$  to  $360^{\circ}$ . What are known in the trade as Surveyors' Transits (a form which we never make), and sold cheaper than the regular Engineers' instruments, have but one vernier. The centres, etc., of this class of instrument are not of a construction to admit of, or made as a general rule accurate enough to allow of double verniers, and of course great accuracy cannot be attained with such instruments. Those who purchase an instrument will find it the best policy to procure one accurate enough for the best work they may ever be called upon to do, but only to work up to the full accuracy of their instrument when the character of the work may require it. As to the amount of error of graduation found in the ordinary run of instruments, it ranges from one to five minutes; † some exceptional cases going even beyond this; but these latter were evidently caused by some disarrangement of the graduating engine, and could not have been overlooked had the instruments had opposite verniers.

As a minute of arc causes an error of over 18 inches in a distance of a mile, in no case should the error of graduation be allowed to reach a minute. It is best in reading the graduations to hold the magnifier as near parallel over the graduations as possible, move the head slightly and notice whether the graduations seem to move; if they do, *parallax* is the cause; raise or lower the magnifier until no movement is seen. It is best not to use a magnifier with too high a power; one from two to three inches focal length is sufficiently powerful for general use. The spacing of the verniers should also be exact—that is, in a minute vernier (reading a half degree plate) they should be precisely 29' apart,—

\* To show that this "*personal equation*" is inborn and not the result of inexperience, we may mention the cases of the two celebrated astronomical observers Bessel and Struve, between whom at one period of their lives it amounted to .8 of a second, and at a later period to a full second.

† Much dissatisfaction with these instruments (Engineers' Transits) was expressed by the assistants; their objections were these,—first, an eccentricity or imperfection of graduation of two minutes, more rarely three minutes, was frequently found in the reading of the verniers of the horizontal limbs, etc.—Extract from Report of Chief of Engineers, U. S. A., to the Sec. of War, House of Rep., pub. doc., 1873.

one common error in verniers is the not spacing all the lines equal (*i. e.*, some being 28' 30'', others 28' 45'' apart). One of the **easiest methods to prove their freedom** from this defect is by setting the halfway line (15') to cut a line on the horizontal limb, and the other three 15' must cut (presuming that the verniers are double, and opposite, properly adjusted, and a truly graduated horizontal limb). **Our own practice in adjusting Transits is to test our horizontal limb with powerful microscopes, by opposite readings and "repeating reversions" on every part of the circle.**

It also serves to keep the instrument in better order if the tripod head, with its levelling screws, can be detached and packed away with the instrument proper. **In travelling** the tripod should have a cap to its head, and a ring to confine the legs. The adjustments will keep better if four india-rubber washers are screwed at the corners of the bottom of the box, as these washers often absorb shocks and prevent their reaching the instrument with so much force. Remember also that the necessarily experienced **frequent adjustment** of an instrument, more especially of the cross wires, is due **not so much to use** as the common error of supposing that the tighter screws are forced, the firmer and more lasting will be the adjustment. On the contrary, something must be strained, and every change of temperature is then more liable to alter the adjustment.

The **adjusting levers** should be **rather short** than otherwise (say about 1½ inches)—inasmuch as by using a long one too much force may be inadvertently applied, and thus either snap a screw or overstrain some more delicate part of the instrument; in fact, a brass wire would perhaps make the best adjusting pin, as it would bend if undue pressure were applied. Another common error is to place leather washers under the levelling-screws. This should never be done, especially on a Levelling instrument, the leather being affected both by the weather and by the pressure of the ends of the screws. It is almost impossible for an instrument with such leathers to retain *precisely* the same line of sight even for a few moments.

The **brass** of which the instrument is made should **not be ordinary yellow brass**, for several reasons—first, because the brass as it comes from the melting-pot is too soft for use, and requires to be condensed with a hammer; and this hammering can never be so equally done but that some parts will be more condensed than others, and unequal expansion and contraction, and hence derangements of adjustment at every change of temperature, are the results; second, the **zinc** which is a prominent part of the alloy of yellow brass will in time by mere atmospheric exposure change the texture of the metal, so as to make it lose a certain percentage of its cohesion. **Lockmakers** and those who use thin brass of this kind for springs well know that if it is exposed to the weather for some time it loses its cohesion, and breaks at the slightest pressure like pie-crust—in their phrase becomes "**rotten**." Of course this is almost an imperceptible change, but some unaccountable variations of the adjustments of instruments (the heavier, the more liable) can only be explained on this hypothesis. **The proper metal for instruments** is an alloy with little or no zinc, and in density at least as close as the best hammered brass; hard "**bell-metal**" being the best.

**A variation plate** is also sometimes added to the ordinary transit in the manner of the variation plate of the ordinary Surveyors' Compass, and for the same purpose. This adds however to the weight of the instrument. Any contrivance for taking sights at a right angle to the telescope will be found useful for offsetting. We always add one to our complete transits.

The ordinary **Plummets** that are used with the transit to centre it over a stake or point will also **require examination**, inasmuch as **some** of these, from cavities in their interior (from defective casting), although apparently solid on the outside, **will not hang plumb**; and in nice operations may be an unsuspected **cause of error**. The best method of **testing** these is while holding the string of the plummet in the hand, to twist the string somewhat, and while the string is **untwisting**, to lower the point of the plummet into a basin of water; if the weight is not truly distributed, and consequently the plummet not true, the eccentric motion of the steel point will scatter the water.

As the **defects of the telescope** will be treated under that head, and those of

the magnetic needle under "Surveyor's Compass," the reader is referred to those articles.

We here close the "errors of workmanship" of the transit instrument; as to the defects of the plan of their construction, and the methods devised for their remedy, the reader will find this subject treated in detail in the paper from the American Philosophical Journal, and in the exhaustive report of the Committee of Civil Engineers, a little further on.

### MINING TRANSIT.

A FULL DESCRIPTION OF OUR NEW TRANSIT, intended for mining purposes, will be found in Prof. R. W. Raymond's paper further on. Since that paper has been written we have made several changes which render them more complete for the purposes intended. Instead of a prism to the eye-piece, an extra telescope is placed on the top of the axis of the regular telescope. This top telescope swings clear of the plates, and allows a vertical sight to be taken directly up or down a shaft; or any angle of elevation or depression to be taken too steep for the central telescope to measure. This telescope makes the instrument similar to the "eccentric or German Mining Transit," with this advantage over that form—that when a steep slope is not required to be measured it can be removed in a moment and packed away in the box, and the central telescope used as usual. This top telescope is adjusted so as to be parallel with the central one. It is also so arranged that the long level and vertical circle of the centre telescope can be used by the side one.

As the proper reading of the graduations is one of the greatest troubles the Mining Engineer has to encounter, we have devised two articles to facilitate it. One is a small reflector that weighs  $1\frac{1}{2}$  ounces;\* the other is a small **attachment** to the transit tripod for **placing a lamp** on; this consists of a **small table**, on which by a "Cugnot's joint" and double centre arrangement a lamp can be placed in any position or angle that may be necessary.—This arrangement is strong, compact and effective, only weighing 24 ounces, and can be packed away in the transit box.

We also make a **lamp** weighing about 5 ounces, which is **more compact** than the one ordinarily used; it is crescent shaped on the interior to fit to the curve of the observer's hat, and a simple arrangement secures it there.—It can be quickly detached and used either in the hand or on the table above mentioned.

**Copper** should always be the material of the Mining Engineer's lamp, and this copper should be tested as to its freedom from magnetic attraction. We now furnish with our **Plummet Lamps** cases large enough to enclose a pair; a strap on the outside of this case allows it to be carried over the shoulder.—The ordinary coal-oil such as is used for lamps is used; the wick to be adjusted for use so that the flame is about  $1\frac{1}{2}$  inches high. These last three (*i. e.*, the Reflector for the cross-wires, the Reflector for the graduations, and the Table) are also useful in **taking astronomical observations** with the ordinary Transit, such as, determining the magnetic variation, the **true meridian**, etc.

### TUNNEL TRANSITS.

The long **Tunnels** which have been built of late years, and the numerous others that are contemplated or in the course of construction, have created an

\* Another invention of this firm is a small reflector attachment to a mine transit, to facilitate the reading of the angles. It is metallic, in shape the quadrant of a cylinder, and it has a base or support which doubles up with the cylinder when not in use. It is placed just behind the vernier opening, and the light is reflected down upon the vernier, thus avoiding the soiling of the instrument with grease and smut, which occurs when holding the light over it, and the reflector can be removed when not in use.—Extract from the report of the committee of visitation of the Polytechnic College to the establishment of Messrs. Heller & Brightly, from the Polytechnic Bulletin, Nov., 1878.

entirely new class of Transits, which to designate them are called **Tunnel Transits**.—These heretofore have been nothing more than the bar and centre of an ordinary Levelling Instrument, with standards high enough to allow of the reversing of the Telescope (which generally has been the ordinary 17-inch Level Telescope); but our attention having been called to the defects of this mode of construction, we have **devised one** that possesses all the accuracy of the Astronomical Transit.\*—In a **Tunnel Transit**, the principal adjustment being that of making the "line of collimation" revolve in a truly vertical plane, the same means employed in adjusting and testing the Astronomical Transit are also employed (*i. e.*, the ends of the axis of the Telescope are cylindrical and resting on small Y's, to allow of its being taken out and reversed end for end. A sensitive striding level is attached to the axis at right angles to the line of sight).

The Telescope should be as powerful as possible, as very long sights are necessary in this class of work.

### LEVELING INSTRUMENT.

A first class Leveling Instrument should possess the following qualities: The Telescope should be powerful enough to read the face of a leveling rod *direct* (*i. e.*, without the aid of a target) at at least 800 feet—the object slide of the Telescope (like that of the Transit) should slide in and out in a perfectly straight line, so that the "line of collimation," when in adjustment for a long distance, shall be correct for a short one.—The tests for proving the optical performance of the Telescope will be treated under the head of Telescope.

The interior of the glass level tube should be ground to a regular curve, so as to secure both accuracy and sensitiveness in the bubble; if the bubble, instead of being cylindrical in bore, should be slightly funnel-shaped (which is very apt to be the case without great care), it will be quite impossible to either adjust or level with accuracy. This serious but common defect is no doubt the unsuspected cause of much inaccurate leveling.

The tripod and head should be very firm, and the centre of gravity of the level as near to the tripod head as possible. The centre of the instrument should be long, firm and well fitted to its socket, and not detachable from the instrument proper.

Inasmuch as it is difficult, on steep sideling ground, for either the rodman or leveller to know whether the rod is held vertical, we always place marks on the collar of the Telescope and inside of the Y's; by observing if these are in contact, the leveller will be certain that when his instrument is leveled his vertical hair is truly vertical, and this enables him to keep the rod vertical, unless the rodman has a plummet or some contrivance similar to our "rod level."

One form of Level (one which we never use) that is liable to constantly lose its adjustments unless great care is used is that in which the cone of the socket enclosing the centre fits into a recess in the tripod head. If any flying dust settles on this socket (which it is almost impossible to avoid), it will cause it to stick so fast that to take the instrument from off the tripod requires a sudden shock upward to release it from the recess; this shock of course cannot but be detrimental to the adjustments. The best plan, when this form of instrument is

\* On the eighth of December, Mr. Heller, of the firm of Heller & Brightly, by invitation, brought their "Improved Tunnel Transit" to the college and exhibited it before the several classes. He gave a short account of the construction of an ordinary Transit and of Tunnel Transits, and explained the adjustments requisite to prove their accuracy, after pointing out the distinguishing features of their Tunnel Transit as compared with the ordinary style, the principal of which Mr. Heller remarked having been suggested by J. Dutton Steele, Esq., and first applied in practice to the Tunnel Transit used by Mr. Steele in the alignment of Nesquehoning Tunnel (Carbon Co. Penna.), . . . and that another one of these Transits was now being used by Robert H. Sayres, Esq., of the Easton and Amboy R. R. in aligning a Tunnel on their road of over a mile in length. . . . At the close of Mr. Heller's remarks, the Principal, after referring to the increase of Tunnelling operations at the present day, and the necessity of all the details connected therewith being closely studied by the scholars, a vote of thanks to Mr. Heller was moved and unanimously adopted.—From the Polytechnic Bulletin, January, 1874.

used, is to be careful before setting the instrument on the tripod to be sure that both the outside of the socket and its recess are scrupulously clean: all the above causes of instrumental error in levelling are well known to those who make levelling a specialty, especially to the "Canal Engineer." The sudden death of the late **Ellwood Morris, Esq.**, prevented the completion of a work for which he was peculiarly adapted, and for which he had been accumulating material for many years, on "**Leveling and Leveling Instruments.**" After serving as a member of the **Committee of Civil Engineers appointed by the Franklin Institute** to examine our "**Improved Transit,**" Mr. Morris entered into a long correspondence with us in reference to the defects of the ordinary Level, and the removal of them, in which he alluded to all the above defects. In referring to the above-mentioned defect of the **object slide, not moving in a straight line**, he remarks: "One trouble I have frequently had—in the aberration caused by moving the tubes for short and long sights.—I once had a Level which I **never could make agree with itself** in a transfer across a river, though I knew it was in good adjustment at all points. . . . I have realized these defects from long experience and much anxiety, but am not enough of a mechanic to give the true remedies. . . . I have said that good work has been done with modern Levels, defective as they are, but it has been with a world of care and trouble on the part of Assistant Engineers, who are very far from being stupid men."

**We were much struck**, in our correspondence with Mr. Morris and others, to learn what a **diversity of opinion** existed even among experts as to what could be called "**close leveling,**"—Mr. Morris in one of his letters asserting, "I have long ago made up my mind that no man can be considered a 'proficient leveller' who cannot run a line of levels in a circuit of 100 miles without differing more than **one-tenth of a foot** upon his closing **bench-mark.**" On mentioning this test of proficiency in leveling to another practical engineer, he retorts in this wise,—"**I have just, with my new level that you furnished me, run one line of levels about ten miles, and when I closed back on my bench to test my work found an error of 0.07 ft.,—this is close work, but it would not be close enough for your friend (Mr. Morris).—If any one should close on his bench with an error so small as he would expect ( $\frac{1}{10}$  in 100 miles), I would say it was simply an accident, and the several errors (rod errors and distant errors) had in the aggregate balanced each other, and led him to suppose himself an expert.**"

**A third thinks** that even Mr. Morris's error is too large, and that the leveling rods that read to  $\frac{1}{1000}$  of a foot do not read close enough, and that for his own use he has had a rod divided so as to read by vernier to  $\frac{1}{10000}$  of a foot,—but as the **Leveling Instrument** of this last expert, which he declared was in perfect order and adjustment, was found, on trial by us, to be out of adjustment  $\frac{1}{10}$  of a foot in 300 feet, perhaps his opinion may not carry much weight.

The result of four series of test levels in France, of from 45 to 140 miles, averaged a difference of  $\frac{1}{10}$  of a foot in 43 miles, and the greatest error was  $\frac{1}{3}$  of a foot in 56 miles; another series of test levels in Scotland of two sets of levels of 26 miles was 0.02 of a foot.

If the instrument is a good one, and in perfect adjustment, and used by a competent person, the only two causes of error in leveling that can occur (except by carelessness) are from what are called "**rod errors**" and "**distance errors**"—the "**rod error**" being caused by the assistant not holding the rod precisely vertical,—the "**distance error**" by the curvature of the earth affecting the result, when the "**back**" and "**fore**" sights are of very unequal length.

To counteract as much as possible these two causes of error, we have devised for the first a "**rod level**"\*—this "**rod-level**" is also intended for setting **transit "flag-poles"** vertical, as well as "**levelling rods.**"

\* "We were also shown a spirit level for the use of rodmen. It is an ordinary disk-level attached to an L-shaped piece of brass, a limb of the L extending downward, and at a right angle with the level. By placing this limb against the side of the rod or flag-staff, and clasping it there, the rodman is enabled to know when his rod is vertical."—Extract from the report of the committee of visitation of the Polytechnic College to the establishment of Messrs. Heller & Brightly, from the Polytechnic Bulletin, Nov., 1873.

For the distance errors, we place on the "diaphragm," or ring carrying the ordinary cross-wires, two extra hairs,\*—these we adjust so as to *precisely* take in 1 foot of a rod placed at 100 feet distance from the instrument.—After taking the level reading, the space on the rod enclosed by these hairs is also noted, and the rod sent in the opposite direction until the hairs enclose the same space.—For example, if the hairs inclose  $3\frac{5}{8}$  feet on the rod, the rod is 350 feet away from the instrument.—To avoid taking the wrong hair in the "level sight" the "Stadia hairs" are placed vertical, and the telescope after taking the level sight must be turned quarter around in the Y's to read them.†

In a recess on the inner edge of the "clips" that confine the telescope in the Y's, there is generally placed a piece of cork, or a spring to bind the telescope.—When this cork, etc., fails to bind, either a new piece of cork must be substituted or paper placed between to clamp.—We have arranged our clips so that by slightly turning a milled head screw on their top the cork is forced out sufficiently to again bind the telescope.

In some level telescopes, it will be observed, while turning the telescope in the Y's, for the purpose of adjusting the cross-wires to the "line of collimation," that the object appears to move with the telescope.—The cause of this is that the object glass is not well centred (*i. e.*, the optical axis of the object glass does not lie in the same line as the axis of the telescope tube); this is a serious defect that can only be cured by substituting in whichever the defect happens to exist a new glass or tube.‡

## TELESCOPES.

A good Telescope should possess power, definition and light; and every part should be made with the greatest care, so as to have as few adjustments as possible.

As to the method by which we have doubled the power of our Telescopes without increasing their length, the reader is referred to the articles on pages 25 and 26.

If two Telescopes are to be compared, as to their power, definition and light, they should be placed side by side, and looked through at the same time,§ in order that any atmospheric or local influence should affect both equally. An optician's test, a watch dial, should be used; the difference of magnifying power between the two instruments can be seen by the apparent size of the dial; and if in one Telescope the dial appears twice as large as in the other, this Telescope has twice the magnifying power.—In the telescope through which the dial appears *brightest*, the light is most abundant; and the sharpness of outline of the figures and minute lines will give a good test of the definition.

If the face of the dial appears sharp black and white, with no tinge of color, and the image as sharp at the edge as at the centre of the field of view, the chromatic and spherical aberrations are well corrected.—Besides the above test (*i. e.*, the brightness of image) for the amount of light passing through the Telescope, let the two Telescopes stand side by side until twilight comes on; the one which will show objects latest has practically the most light.

Adequate magnifying power is the first requisite in a Telescope, not only for viewing objects at a distance, but for the purpose of doing more accurate

\* See article on Stadia measurements.

† These Stadia hairs will also be found useful as a means of measuring distances quickly when "flying levels" are taken.

‡ This "error of centring" must not be confounded with the error of the line of collimation not being the same "for long and short distances," the first being caused by a "defective object glass," the second by a defective "object slide or tube."

§ The best time for telescopic observations is not when the sun is shining, as is generally supposed; on the contrary, a *clear* cloudy day, or when the sun is slightly obscured. Recollect also that the best sight is always in a direction opposite to the sun (*i. e.*, sighting to the west in the morning, to the east in the afternoon). A good background to the object will facilitate the view (the sky is a very good one if it can be obtained): if none can be had naturally, improvise one of some neutral tint behind the object. This is specially needful in long ranges.

IMPROVED 17" IN. Y LEVELING INSTRUMENT.

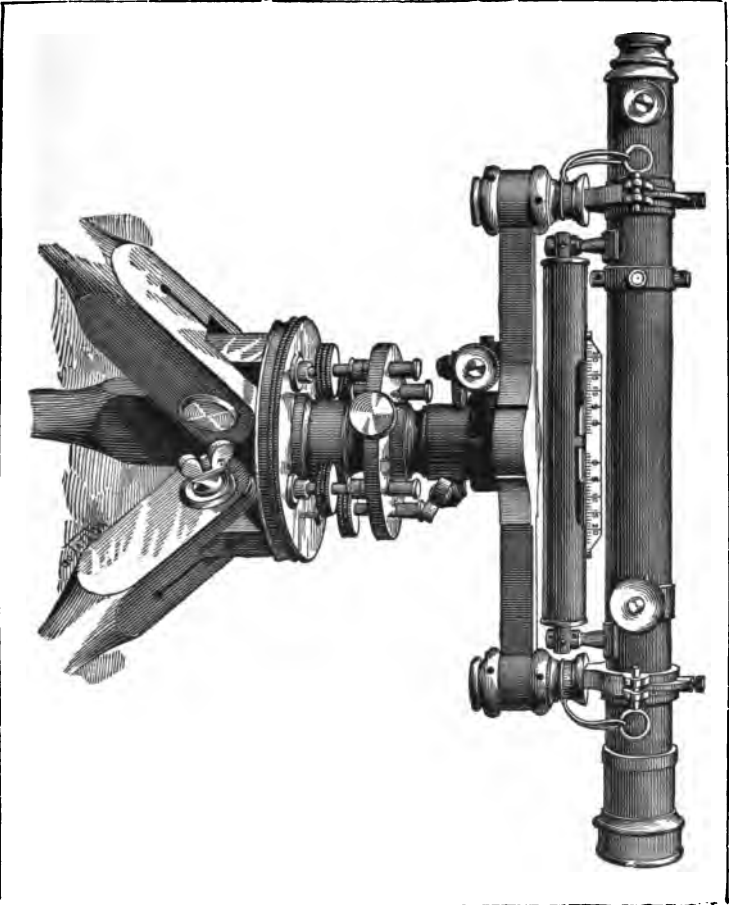

MADE BY  
HOLLER & BRIGHTLY, PHILADELPHIA, PA.



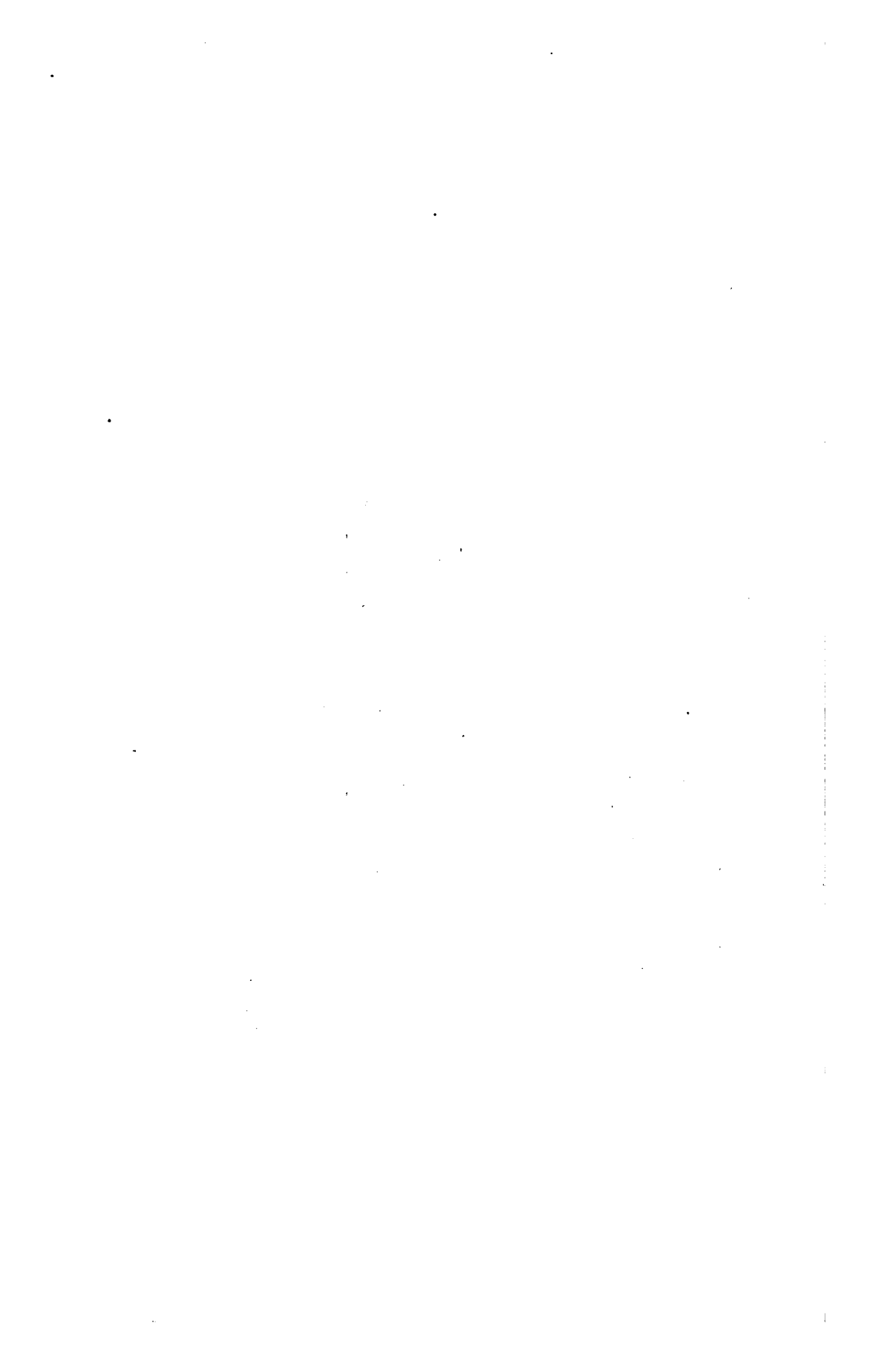

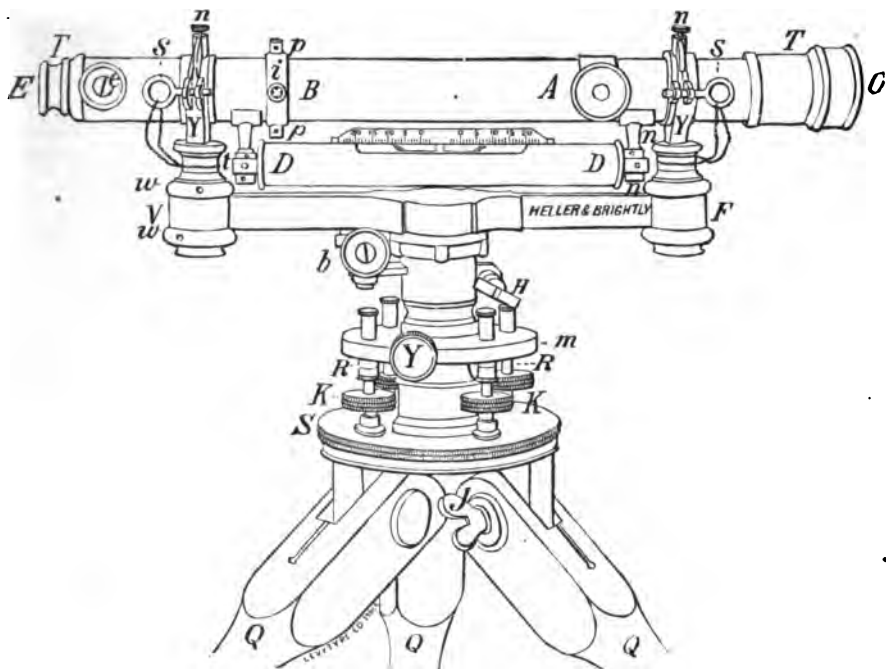

## LATE IMPROVEMENTS PEOUILIAR TO THE HELLER & BRIGHTLY LEVEL.

**Agate bearings** on the inside of the Y's for telescope T to rest and turn upon. These **agate bearings** do not allow the telescope to alter its adjustments so frequently as when the telescope merely turns in brass.

A "stop" on the telescope, and a "shifting-bar" on the inside of each of the Y's. When the stop and shifting-bar are brought into contact the vertical wire of the cross-wires is then truly vertical, or will cut a plumb-line.

This avoids the necessity of setting the vertical wire vertical by means of sighting to the edge of a building or a plummet-string, as is the case in the ordinary level.

K.—Attaching clamp, clamp-screw H, and tangent-screw *b* to the bar of the instrument, so that they are carried around with the bar V F and telescope T, and therefore will always maintain the same relative position.

n.—At *n* there are two spiral springs pressing gently against ivory bearings. These bearings bind the telescope in its Y's, thus avoiding the common use of cork, paper, etc.

The adjustment to the eye-piece (for focusing the cross-wires), dust-guard I to object-side of telescope, dust-guards *f* and *g* to the leveling-screws K, the ball-and-socket-motion *k* to the leveling-screws, the improvements to the tripod-legs Q, are similar to those on the Transit, and are fully described under the illustration of that instrument.

T.—Telescope.

Y.—Supports for telescope. Called Y's from their shape.

n.—Clips for confining telescope T in Y.

s.—Binding-pins.

w.—Large capstan-headed nuts for raising Y up or down in adjusting.

b.—Tangent or slow-motion screw for moving the bar and telescope. The tangent-screw *b* has a device for overcoming all lost motion. (See notes accompanying Transit illustration.)

h.—Clamp-screw for binding the instrument to its centre.

h.—Finger-piece for moving the eye-piece (by means of a concealed rack and pinion) to the focus of the cross-wires at *p*.

Ordinarily, this focusing is accomplished by pushing the eye-piece out or in by hand; the rack-and-pinion motion is, however, more simple and accurate.

For explanation of other parts of the telescope, tripod, and instrument, see explanatory notes under illustration of Transit.



work at comparatively short distances, as the ease with which sights can be taken and judged adds to the facility of the field work. Besides the above tests, after precise focussing of an object **the slightest pushing in or drawing out of the object glass** (by means of its milled head pinion) from the point of distinct vision should render the image confused and indistinct, "for a Telescope that will admit of much motion in the sliding tube without affecting sensibly the distinctness of vision will not define well at any point, for its object glass has spherical aberration."

**The following test** will show whether the glass is **perfectly achromatic** (or without color): "focus on a bright object, such as a star, etc.; alternately push in and draw out the eye piece from the point of distinct vision. If in the former case a ring of purple is formed around the edge, and in the latter a light green (which is the central color of the prismatic spectrum), the glass is achromatic, for these colors show that the extreme colors red and violet are corrected." **The placing of diaphragms** or stops within the object slide or body tube, so as practically to reduce the diameter of the object glass from  $\frac{1}{2}$  to  $\frac{1}{4}$ , is a common but reprehensible practice, inasmuch as such diaphragms exclude light, so that operations cannot be continued to as late an hour in the afternoon.

**On examining the object glass head** of our Telescopes, an **index mark** will be found across the cell of the glass and the head of the slide.—The object of this is, in case the object glass cell is ever taken out, that by seeing if these marks coincide when it is again screwed in, we may know that it is at the same place; or that the glass has not gotten loose by transportation.

**Defective centring of the object glass**, and of the lenses of the eye piece, and crooked tubes are by no means uncommon.—These last defects, however, may be concealed (except from experts) by screw adjustments (in the manner of the web diaphragm) of the eye piece and object glass.—These last, however, if the glasses and tubes are true, are unnecessary; for **if the object glass and the lenses of the eye piece of a Telescope are properly made and mounted, the tubes perfectly straight, the slides properly fitted, the line of collimation (when adjusted) must come in the centre of the field of view, and if it does not, something must be wrong** in some part of the Telescope, and any means of adjustment only conceals the evil.

One **error of judgment** is also sometimes made, and that is that the bore of the Telescope tube itself is so small as to cut off considerable of the light from the object glass.—Some Engineers prefer a **small hole in the eye cap** to sight through, others a large one,—but they must recollect that the size of this hole, as well as the size of the Telescope tube, is fixed by rule.

The eye-cap hole should always have a slide to cover it.—Both this and the cap on the object glass should always be kept on when not in use. This is a point that is almost universally neglected; the cap as a general rule being lost within a few weeks' time; but if it is recollected that the **fine polish of the object glass** gives in a great measure the sharpness and **brilliancy to the object**,—which if this polish is destroyed is also in a measure destroyed—more attention would be bestowed on it. Any one who has looked through an old ship's Telescope in which the polish has been destroyed by constant wiping of the glasses may have observed this.

If the **object glass becomes dusty**, brush it off with a fine camel's-hair brush, or a piece of *soft, clean* buckskin, linen or silk, taking care to use a fresh place on the buckskin at every rub. If the glasses become very dirty, wash them with alcohol.

## SURVEYOR'S COMPASS.

**In a good surveyor's compass** the slits of the sights should be *precisely* in a line with the two zero lines of the ring,—and these sights at right angles to the main plate.—It should be as light as is consistent with strength and steadiness. **The magnetic needle** is, however, the main point, and any one of the following defects will prevent its free working—bad steel,—too great heat in forging,—improper tempering or defective magnetism.

We sometimes receive communications from parties wishing to make magnetic needles,—the following will give them the information sought for.

**The steel** should be either of **shear** or the **best cast steel**, converted from Swedish Danemora iron (shear steel being the best, however).—If the needle is forged into shape, care should be taken not to overheat it during that process.—After filing and finishing into shape and length, it is to be **hardened and tempered**, and it is this operation that is most liable to be improperly performed,—the needle being so thin that it is apt to get too hot in places, and burnt steel never magnetizes properly.

**Our own method** is to heat a **crucible of lead** to a cherry red color, and to heat the needle therein, and when it is to the proper heat plunge it into water,—the beauty of this method being that, even though the needle be allowed to remain a considerable time therein, it can never attain a greater heat than the lead itself has.

**After hardening**, the needle should be tempered.—A good rule for the **degree of hardness** to which the steel is to be reduced is this: when the **length** exceeds **thirty** times the thickness, to temper to dark red, or **red blue**,—when the length is **under this**, to leave them **untempered**.

**In magnetizing**, two methods can be employed, first, by passing over each end the opposite poles of a fixed magnet; second, by a magnetic coil. If the first method be the one employed, a **thin film of oil** on the needle during magnetizing will greatly increase the power; but the method that is most certain of thoroughly magnetizing to "**saturation**," and with no possibility of "different polarities" being developed, is by passing the needle through a magnetic current.

To any one who wishes to make a coil for this purpose, the following hints may be useful. A cylindrical coil of copper wire as thick as it is long,—this cylinder to have a bore equal to its thickness, (the copper wire to be rather thick. Our own coil is of  $\frac{1}{4}$  inch thick wire).—**The exciting power** to be a voltaic apparatus on "Groves'" principle (platina and zinc);—and the needle to be magnetized passed up and down the interior of the copper cylinder.

**After being magnetized** it is necessary to know if this has been done properly (*i. e.*, if the latent magnetism of the needle has been fully developed, and if this magnetism is permanent); to prove the first the needle should lift a certain amount of soft iron; (our own needles will lift ten times their weight).—Second, after **noting the amount raised** on first magnetizing, it should be tried, after say a week's time, and it should then have lost but little of its power.—It must be recollected that a soft, untempered needle loses almost all its magnetism within a comparatively short time, though at first it will develop as much, if not more than a tempered one.\*

**The pin and the cap** on which the pin works, require a peculiar shape;—the centre of the cap to be at as obtuse an angle as possible, consistent with having a proper centre, and this centre perfectly smooth;—**the centre pin** to have a hard, round, smooth point; and this point with not too obtuse an angle. Defects of these two last, (cap and pin) are in eight cases out of ten the cause of the dull working of the needle.

**To preserve the fine point** of the centre pin from unnecessary wear or from being accidentally broken off, never jolt nor carry the compass without being sure that the needle is screwed off the pin.—In using the needle, lower it carefully, so that it gently rests, and does not fall upon the centre pin.

**To prevent unnecessary wear** of the centre pin, check the needle on first letting it down at the mean of its swing (*i. e.*, if the needle swings from say  $0^{\circ}$  to  $30^{\circ}$ , check it by raising it off the pin by means of its screw at  $15^{\circ}$ ; gently let it down again, and it will be within a few minutes of its proper settling place).

**Never allow the needle to be played with** by a knife or a piece of iron or steel, for two reasons;—first, the instrument should never be made a plaything; second, every near passing of a piece of iron or steel removes a portion of the

\* If the reader wishes to investigate thoroughly the subject of magnetism and magnetic needles, he will find ample material in the works of Scoresby, Sabine, Brewster, or the *Encyc. Britannica*, art. Magnetism.

magnetism of the needle (almost the entire magnetism can be removed by a series of such passings). A needle should never (excepting for special purposes) be more than six inches long, it being very difficult to magnetize properly beyond this length without developing different polarities on the same side of the needle. A five inch length is very good.

Be sure that **nothing to attract the needle** is carried on the person in the shape of penknives, watch-chains, buttons, or iron rivets in the magnifier used to read the graduations. Of late years new causes of error from this have arisen. The new watches in which the movements are made of nickel are almost as powerful in attracting the needle as if these movements were made of iron. The felt hat-makers' modern fashion of stiffening the rims of their hats by inserting around the edge a small iron wire (the extra broad brimmed, termed the military or Burnside hat, should especially be tabooed) should make the Surveyor examine both his hat and watch.

There is one source of error which even the manufacturer must have a special apparatus to detect; and this apparatus is as essential a part of his equipment as a lathe. This is a sensitive, mounted magnetic needle; and every piece of brass, even of the smallest size, is tested by being brought near to this needle, in order to see whether any magnetic attraction is concealed. The brass-founder is the one here in fault, as impure copper or the smallest piece of iron, such as a tack, core wire, or stirring his melted crucible with an iron rod will engender this cause. These impurities, melting and diffusing throughout the brass, although imperceptible to the eye, are brought to notice by the searching influence of the test needle. All the surveyors' Compasses made before the last 80 years are especially liable to error from this cause (those made by Rittenhouse are, however, notably free from it;)—and those who own any such should have them tried by some maker's "test needle" to prove their freedom from it.

It would be a matter of surprise to some to know how many needle instruments are defective from this cause, and we will give one instance that occurred lately.

An English Compass, venerable with age and the associations connected with it, had been constantly used by a Surveyor for over 50 years, and by his father before him. This Compass was held in such repute that all the farm lines in a radius of 100 miles had been established by it. In fact, the Surveyor and his Compass were held in such veneration as to be called in to settle every land dispute in the neighborhood, and the judgment of the two was considered final. At last the old Surveyor died, and such was the desire of the surrounding land Surveyors to possess this Compass that at the auction sale of his effects it was sold for treble the price a new one could have been bought for.

The fortunate possessor brought it to us for cleaning and adjusting; and some vagaries that took place in the adjusting induced us to give the instrument a thorough examination; and we found that this defect of "impure metal" was present in such a marked degree that in turning the instrument on its centre it was sufficient to draw the needle from its proper position from 10 minutes to  $4^{\circ}$  (in some spots  $5^{\circ}$ ).\* We are not surprised to hear, since the old Surveyor's death, that several lawsuits are in progress in this locality from land disputes.

One common error of Surveyors is to choose a heavy needle; this is a mistake. A heavy needle soon wears out the fine point of the centre pin. The superficial surface, and not the weight of the needle, determines the amount of magnetism it is capable of receiving.

One simple effect has sometimes bothered the young Surveyor. His needle will sometimes not traverse, but will persistently stick to the under side of the glass; or one end at the lightest provocation would fly up to the glass and remain there. This is caused by the glass becoming charged with electricity (from rubbing against the clothing, or being rubbed by a silk handkerchief). Touching the

\* This unequal attraction is one of the worst features in this imperfection; if the iron were equally distributed throughout the metal, the attraction being equal, the needle would still point true.

upper part of the glass in several places with the moistened finger tip, or breathing on the glass, will remove the electricity.\*

### SOLAR TRANSIT AND COMPASS.

**The Solar Compass**, or Solar Transit, as ordinarily made, has the following defects:—first, it is very heavy and cumbersome; hard to get in adjustment, and very liable to lose its adjustment; and the Solar apparatus, by occupying the upper surface of the plates, prevents a Telescope being added in the manner of an ordinary Transit.

**The best method to prove** the Solar apparatus is the following:—Two hours before the sun culminates (10 A. M.) set up the instrument, level it carefully; with the latitude arc vernier set to the latitude of the place, and with the sun's declination for that hour laid off on the declination arc, move the whole instrument until it is in its meridian (*i. e.*, until the sun's image comes between its lines); let it stand until the sun is as much beyond its meridian as in the first observation it was before it (2 P. M.); the 4 hours' difference of declination are to be added or subtracted (as the case may be) on the declination arc;—and if the sun's image still keeps between its silver lines, the polar axis of the instrument is parallel to the earth's polar axis; and the sun's image on the silver plate will follow the sun in its path during the day (allowance, however, being made for the refraction and hourly difference of declination).

It is, however, in very rare instances, that the instrument will stand the above test, its polar axis being generally out of adjustment so much that the afternoon's observation will require it to be moved east or west of its meridian from 5' to 45' (in some cases even more than this), to bring the sun's image again between the lines on the silver plate. If, however, the instrument stands this test, it only proves the truth of its Solar apparatus, and we must try whether the Telescope or sights are placed by the maker on the true meridian.

**The best method** of testing this is with an ordinary Transit, and an observation of the North Star, to first establish a true meridian line; and after setting up the Solar in the regular way, see whether the sights or cross hairs of Telescope cut the same line. By this observation it can also be seen whether the magnetic variation of the place agrees with the variation shown by the Solar Compass; and if not, the movable arc of the needle box vernier can be shifted until it does so.

**The successful addition of a Telescope** to the instrument has not heretofore been accomplished. The inventor, Burt, after numerous attempts, contented himself with placing a small inverting Telescope at the south end of the Compass plate; but the necessarily small size of the Telescope, and the one-sided weight that it added to the instrument, make this method an imperfect one.

**Another method** is to place a Telescope on the side, as in the "German Mining Transit;" but the side weight is also added to the instrument; the difficulty of adjusting the line of collimation of the Telescope, and the line of sight of the telescope, and the centre of the instrument not being in the same line, requiring a constant of this "difference of centre" to be applied to every sight, prevented it from becoming popular.

**The standards** of the Telescope of an ordinary Transit have also been bent outward, so as to allow the Telescope to reverse outside of the Solar apparatus—but as long as the Solar apparatus remains on top of the plates no Telescope can be successfully applied.

**The first idea of the inventor**, Burt, was to place the Solar apparatus below the main plates, which would have solved all the trouble as to the Telescope; but as on experiment it was found that the lens, to form the sun's image, must have a six inch focal length (and consequently a six inch bar), this was abandoned.

We find that the Solar apparatus devised and patented by G. N. Saegmuller overcomes all the above defects,—is more accurate, easier adjusted, and keeps its adjustments better than any other form, and we have (1888) adopted it where a solar apparatus is required.

\* See also "an unsuspected source of error in magnetic needle readings of surveying instruments on page 6 of Centennial Engineering Facts."

### ON THE DEFECTS OF THE ORDINARY CHAIN AND STEEL TAPE MEASURES, WITH AN ACCOUNT OF A NEW MEASURING APPARATUS FOR STRAIGHT LINES.

Before mentioning a new measuring apparatus, it might perhaps be best to allude to those in common use, and the objections found to them in actual practice.

The defects of the ordinary chain are too well known for us to enter much into detail—its weight, the unavoidable wearing of the points of contact of its numerous links and rings,\* the kinking and breaking of the links, etc.

The English steel ribbon tape is much more accurate, but it also has its defects; first, they are never precise United States standard length, it being our practice, whenever we furnish one of these steel tapes, to give its length as compared with the true United States standard, and the state of the thermometer at the time of trial. We have found that the 50 feet tape is generally from  $\frac{3}{100}$  to  $\frac{1}{100}$ , and the 100 feet from  $\frac{1}{100}$  to  $\frac{1}{100}$ , of a foot too short (the 50 feet over  $\frac{1}{4}$  of an inch, 100 feet  $\frac{1}{2}$  an inch, or in a mile more than 2 feet too short). The amount of error is small, and in a majority of cases would be of no consequence; but where accurate measurements are required would lead to error; second, the numerous joints in their length, (every joint in a tape being a source of weakness and inaccuracy);—their never being over 100 feet in length—(and in numerous cases, such as measuring across bridge piers, rivers or marshes, in shafts of mines or tunnels, etc., it is necessary to have a greater length than this)—their liability to breaking, and lastly their cost.

Having had occasion to make a measure 500 feet long that should be light, not easily broken, and very accurate, and not too expensive, we have devised a tape that fulfils these conditions. We are now prepared to furnish these tapes of any length, from 100 to 1000 feet, in one continuous ribbon—having no joint from end to end, and warranted precise United States standard in length. Large brass handles to unship at each end and a reel to wind the tape on are also furnished—as to their weight, a 400 feet tape (without handles) weighs  $2\frac{1}{2}$  pounds.

We are well aware that tapes of this material have been made before, but for the following reasons have never been popular. First, no reels were furnished with them; second, the steel ribbon, being of soft steel (not tempered), was liable to alterations in length. (Our own tape stretches taut with a strain of a few pounds, and after being taut allows of an extra strain even to breaking without perceptibly altering the measure); third, the graduations and numbering being scratched on the face of the tape itself, and the tape always breaking at these marks in cold weather, or when the tape was kinked in the slightest. To prevent this breaking, the graduations have been etched with acid on the face of the tape, or the marks were placed on a thin layer of tin soldered on the tape. But these marks were not legible enough, hard to find, and easy to efface.—The

\* If each of the 300 points of contact of a 100 foot chain (each link with its two rings having three points of contact) wears only the  $\frac{1}{100}$  of an inch, making 3 inches difference  $\frac{1}{100}$  the whole length.



marking of our tape is by a device entirely our own. It is not upon the face of the tape itself, is very legible, and the tape is stronger at the graduations than at any other portion.

For Mining and Bridge purposes these tapes are peculiarly adapted—the unshipping of the handles allowing the end handle to be taken off after a measurement, and the tape to be pulled forward with no handle to catch in any obstruction.

In City work tapes for close measurements are not used, but what are termed "Contact Rods" are adopted. These are rods of a certain length (10 feet being the most common), and are used in pairs; the two being joined together when in use by a "clamp socket" in their centre; or, after one is laid level, the second is brought in contact with it: the first one is then removed, and also then brought in contact with the second one, and so continued.

These rods are usually made from some well-seasoned, straight-grained wood, such as ash, cedar or pine, the wood protected from the weather by paint or varnish, the ends shod with brass, and the whole length made very exact in its measure.

In making these Rods, our own experience is that good, seasoned, straight-grained white pine, of what is termed "rafted lumber" (i. e., wood that has been floated to its place of destination in rafts), is to be preferred. The immersion in the water for weeks washing all the sap from the timber, and thus too lessening its liability to change.

### STADIA OR MICROMETER MEASUREMENTS.

As considerable attention is now being bestowed on what are termed Stadia or Micrometer measurements, and this method being almost the only one that can be employed sometimes in such measurements as across rivers, inaccessible morasses, meandering along rivers and streams, etc., we will give a brief account of the means employed.

One method is this—first, carefully measure off say 100 feet on the ground, place a levelling rod at this point, and note on the vertical circle of a Transit the angle passed over by the horizontal cross wire of the Telescope, in moving over one foot of the Rod; and from this as a constant, a table is made. The second method is similar to the first, except that instead of reading on the vertical circle, the space passed over by the Telescope is noted by observing the number of revolutions and parts of revolutions of a tangent screw (by means of a micrometer head), and using this as a constant.

In this last method the instrument must be very carefully used; for if the tangent screw has the least "lost motion" or "back lash," or if the screw threads wear unequally, the micrometer head will not measure correctly.

The first method is preferable to the screw; but the vertical circle should be larger than usual, so as to allow of a vernier reading to less than minutes of arc. Both of these methods require, however, constant care in the observations, and after calculations to get the precise distance. The United States Coast Survey, who have given the greatest attention to Stadia measurements, have adopted the two-hair method in their "Plane Tables." This is the one we prefer, and is as follows:—beside the ordinary horizontal and vertical cross hairs, as seen in the field of view of the Telescope, two extra horizontal hairs are placed parallel with the central one, and equally distant on each side from it.

These two extra hairs are so placed that if a levelling rod is held 100 feet from the telescope, they will enclose one foot of its length. With this as a constant (1 foot in 100 feet), a table can be made, and any distance that the Rod may be from the instrument can be precisely measured by reading its face (i. e., if the hairs take in  $2\frac{3}{16}$  feet of a rod, the rod is just 250 feet away,  $3\frac{1}{16}$ , 310 feet, etc.).

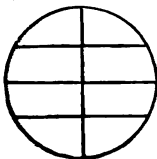

Stadia measurements have not heretofore given as good results in this country as in Europe, for the simple reason that (outside of the Coast Survey) the Telescopes have not had suffi-

cient power to read the rod, with the closeness consistent with the accuracy required for this operation. Our new Telescopes, however, remedy this.

There is one fact in regard to Stadia measurements that is very little known, even by those who are constantly employed in using it on Plane Tables and other instruments; and which will account for many of the inaccuracies of Stadia measurements in close work.

The starting point for the Stadia measurements is generally supposed to be indiscriminately—either the centre of the instrument—the centre of the cross hairs—or from a plumb line dropped in front of the object glass; and all three places have their advocates. These are all wrong, however—the precise place being a point as far in front of the object glass as is its focal length;\* for example, if the focal length of the object glass is six inches,† the starting point is a point six inches forward of a plumb line dropped from the front of the object glass—and if a measurement be required from one fixed point to another, place the instrument back from the starting point this amount.‡

A still better mode, however (where a transit is used), is to also measure from the object glass to the centre of the axis of Telescope, and add this also to the focal length of the glass, and all the measures will then be from the centre of the instrument, bearing in mind, however, that this amount is a constant, and must be added to the recorded Stadia reading at every sight or change of the instrument. We will take, for example, one of the ordinary Transit Telescopes.—The object glass of six inch focal length, and the cross wires placed close up to the axis of Telescope, or about six inches from the object glass. In this case one foot must be added to every Stadia sight (not to every 100 feet), to bring it to the centre of instrument. In cases where the sights are long, this small amount is of no consequence; but where a series of short sights are taken—for instance, in a mine gangway—one so tortuous that seven sights of 100 feet each are necessary in that length, if the measurements are from the centre of the instrument, and a Transit of the above description employed, if this “constant of the focal length of objective” is not allowed, there would be an error of 7 feet.

\* If the size of the object seen through the telescope be called  $s$ ; the distance from the object to the centre of the objective  $a$ ; the size of the conjugate image of the object, equal to the distance apart of the two horizontal cross hairs,  $i$ ; the distance of this image from the



centre of the objective  $x$ ; and the focal length of the objective  $f$ ; then,  $\frac{a}{x} = \frac{s}{i}$ ; But the gen-

eral formula of foci of lenses gives  $\frac{a}{x} = 1 - \frac{a}{f}$ . Therefore,  $a - f = \frac{f}{i} s$ ; or  $a = \frac{f}{i} s + f$ .

Practically, the distance  $a$  has commonly been reckoned so large that the small distance  $f$  was neglected, and the formula became  $a = \frac{f}{i} s$ ; in which  $\frac{f}{i}$  is a numerical coefficient peculiar to

the instrument, and determined by observation once for all. The distances, in that case, are reckoned proportional to the space cut off on the rod, counting from the centre of the instrument, whereas they ought strictly to be counted from a point as far in front of the objective glass as the focal length of that lens.—Extract from paper on Telescopic Measurements in Surveying, by Benjamin Smith Lyman, Esq., in the Journal of the Franklin Institute, April, 1868.

† The focal length of any glass can be found close enough for this purpose by focussing the Telescope for an ordinary sight, and then with a foot rule measuring from the outside of the object glass to the capstan head adjusting screws of the cross hairs.

‡ I was much bothered at first about the difference between the results given by the instrument and the tape, when the distance was small, say under 100 feet; I had assumed that the space covered upon the rod was proportional to the distance from the centre of the instrument, instead of a distance in front of the instrument, equal to the distance from the centre of the instrument + the focal length of the object glass.—Engineering News, May, 1875.

The diaphragm to which the slides for carrying the Stadia wires are attached requires peculiar care in the workmanship, as the two slides to which the two extra hairs are attached (for the two hairs ought to be adjustable, independent of each other or of the ordinary cross hairs) must move firmly, truly and smoothly, so that at any time the hairs can be adjusted with the ordinary adjusting pin without disturbing the adjustments of the ordinary cross wires.

In closing these remarks, it may be advisable to call attention to one cause of instrumental error which sometimes comes under our notice. We refer to cases where instruments injured by accident or worn by use are placed for repair in the hands of incompetent persons, or those who have not the facilities for properly repairing first-class work. This is not so uncommon as may be supposed. One extreme case of it was recently brought to our own notice, where a very costly and accurate instrument (made in Germany) was for ten years classed as having an inaccurate graduation and an inferior Telescope; when in fact both faults were the result of ignorance in repairing the instrument.

The centre upon which the instrument turned had originally been made in a "dead centre lathe" (see page 4), but the repairer had replaced this centre (for which change there was no occasion) with one turned on an inferior ordinary lathe; and in attaching the new centre, it had drawn the horizontal limb to one side in such a manner that the graduations were over seven minutes (7') from their true place; and moreover, in "improving" (?) the telescope, the diaphragms in the eye piece had been altered from their true places, so as to cut off over half of the light that should have passed through the Telescope.

It is the best policy, where repairs may be needed, to put the instrument into competent hands; and if none such can be found in the immediate neighborhood, the railroad Express system of the present day allows such to be readily reached.\* See page 43, "How to Send Instruments for Repairs, and Table of Express Charges."

\* In conclusion, we would state that if any gentleman who owns an instrument, and wishes to compare its power, etc., with ours, will bring it to our office, we shall be happy to assist him in doing so. We have a watch-dial placed at a sufficient distance from our room to afford a satisfactory test.

---

From the Monthly Report of Novelties in Science and the Arts, read by the Secretary of the Franklin Institute, at the April meeting of the Institute (April 21, 1875.)

### EUROPEAN DEMAND FOR AMERICAN ENGINEERING INSTRUMENTS.

In speaking a couple of meetings since of the foreign demand for Philadelphia manufactures, the following additional items may be of interest in this connection. Messrs. Heller & Brightly, the Mathematical Instrument Makers of this city, have recently received and are now filling heavy orders for Engineering Instruments (Transits and Levels) from Vienna, Germany, and from Bristol, England. When it is recalled to mind that up to within a comparatively recent date all the most accurate instruments of this class have been imported from Europe, and that this is the first instance known where instruments of this class have been imported into Germany from this country, this fact is deemed worthy of notice. Messrs. Heller & Brightly are also now filling orders for Engineers' Transits and Levels, etc., for the Imperial College (Kaga Yashiki), Tokio, Japan, from Yokohama and Kokaïdo, Japan, and Hong Kong, China. They have also recently shipped a number of their instruments to Meigs, of South America, and have present orders for their instruments from Concepcion, Chili, Havana, Cuba, Nacupai, Venezuela, and the Chimbote R. R., Peru. Neither do our City Engineers go abroad for their instruments, as the Centennial grounds and buildings (views of which were given at our last meeting), the Geological Survey of the State of Pennsylvania (now in process), the new Girard Avenue, Fairmount and South Street bridges, and the League Island Navy Yard, are all being laid out by means of Instruments made by this firm.

**PAPER READ BEFORE THE AMERICAN PHILOSOPHICAL SOCIETY, MAY 5, 1871, BY PROF. J. PETER LESLEY.**

(From Journal Proceedings American Phil. Soc., Jan. to July, 1871.)

**Heller and Brightly's New Transit.**

The Engineers' and Surveyors' Transit, as at first constructed, commonly termed a "flat centre," or "Railroad Transit," although superior to the English Theodolite, which it superseded, yet in practice has been found defective in the following mechanical details:

1st. The upper or vernier plate, resting, and turning upon the under or graduated limb, was accompanied by so much friction, caused by the large extent of the rubbing surfaces, that, in turning the vernier plate around the limb, the whole instrument would sometimes be moved upon the lower spindle. 2d. The oil that was necessarily used to lubricate the plates, would become so congealed in cold weather that the plates would not move at all, and old Railroad Engineers will readily recall the thawing out of their instruments over large fires, at every fall of the thermometer, before they could be used. 3d. The spindle upon which the entire instrument turns, being detached from the instrument, thus violating one of the standard rules, that, by long experience in this country and Europe, has been found necessary in the construction of any instrument with any pretensions to accuracy, viz.: "*any instrument having a graduated plate and levels, should be so constructed that both of the centres upon which the instrument turns, should be always covered and not detachable from the main plates.*" To prove the utility of this rule, it is only necessary, after adjusting the levels of one of this class of Transits, so that they will reverse on the top centre, to clamp the two plates together, and turn the instrument on the lower spindle, and the levels will invariably be found out of adjustment, showing conclusively, that through some cause, most frequently the settling of flying dust, etc., upon the surface and shoulder of the spindle, the spindle is not at right angles to the surfaces of the plates. 4th. The centre around which the graduated limb revolves, can only be the thickness of the graduated limb; this centre, by reason of its small surface, wears after comparatively short use, and does not exactly fit the conical hole in the graduated limb; and two readings of the same object taken without any change in the position of the instrument, have been found to differ by 5', and from no other cause than this.

These various defects have caused this style of instrument to be entirely discarded in city work, and for this another construction is used, in which the two main plates do not touch each other, thus obviating the two first evils, viz.: the friction of the two plates rubbing one over the other, and the stiffness of motion of the plates in cold weather. The sockets and spindles upon which the main plates revolve, being long and fitting one inside of the other, and neither of them being exposed or detached from the instrument, thus remedying the two last causes of error. These two are the only styles of Transit made, and are respectively termed the "short centre Transit" and the "long centre Transit." The "long centre," although the most perfect in its construction, has never been a favorite among Railroad Engineers for the following reasons:

1st. The increased size of the centres making it heavier, and this being a very serious objection where an instrument must be carried several miles every day, as is frequent in Railroad surveys. 2d. The instrument not being detached from the tripod, except at the base, compelled the Engineer in moving the instrument from one station to another, to either carry the entire instrument himself, or trust it to his assistant; while in the short centre, the instrument lifting off the spindle, the Engineer could take the comparatively light instrument, with all the important parts, and leave his assistant to carry the heavier portion of the tripod, with its leveling screws, legs, etc. 3d. The removing and replacing of the instrument on the tripod, being accomplished by means of a large screw thread, is a very tedious and unsafe method, and if not very carefully performed, is liable to injure the instrument. 4th. The extra skill, time and care required in making the long centre, was so much greater than the flat centre, that the price of the instrument was materially increased.

Ever since the introduction of the Transit, numerous endeavors have been made to reduce the weight of the instrument, but as they have all been conducted on the same

principle—i. e., reducing the thickness of the various plates, etc.—their only effect was to make the instrument so slight as to be unsteady, their bearing surfaces so short as to soon wear loose, and the instrument always losing its adjustment. The manufacturers of this instrument have had their attention drawn to the increased strength and steadiness that the employment of the “transverse section,” “ribbing or bracing,” imparted to metals; and the amount of metal that could be removed from a solid plate of metal, and its strength and steadiness not impaired, but even added to, if only judicious ribbing was resorted to. In this improved Transit, which is a long centre, the weight as compared with an ordinary Transit of the same size, is reduced one-half, and the instrument is not contracted in any part, but in some parts, where increased size would be an advantage, such as the graduated plate, centre, etc., it has been done, but all the plates, etc., are ribbed in such a way, as to be stronger than a solid plate, and all metal that did not impart either strength or steadiness has been removed.

The Railroad Engineer has in this instrument, a long centre Transit that can be taken from off the tripod and replaced in a quicker and surer way than the short centre Transit, but, unlike the short centre, keeps all the centres covered and not removable from the instrument, and leaves the tripod head and legs with the four levelling screws, etc., to be carried by his assistant. The difference in weight will be appreciated by the Railroad Engineer, when we inform him that a plain Transit, with all its centres, etc., only weighs about as much as a Surveyor’s Sight Compass; and is more steady and keeps in adjustment better than the ordinary long centre Transit, weighing from twenty-five to thirty pounds.

The City Engineer has in this instrument all the advantages of the ordinary “long centre Transit” with only half the weight, and an increase of steadiness.

There are several defects that are common to all Transits, among which are—

1st. The “tangent or slow motion screw” that moves the upper or vernier plate, by use becomes worn, and does not fit precisely the thread in the interior of the nut through which it passes. When this occurs, the tangent screw can be turned sometimes a complete revolution without moving the vernier plate. This “lost motion” or “back lash” of the tangent, is one of the worst annoyances of Engineers, and has been the source of serious errors in the field. Several methods have been devised to overcome this, which we will here describe. The nut through which the screw works has been made in two sections, to allow of being drawn together when the screw wears. This plan would answer if the screw always wore equally in every portion of its length—in other words, was a cylinder—but this it never does; and if the nut is tightened so that the lost motion is removed from the thinner portion of the screw, it will move so tightly as to be useless when it comes to the portions that are not worn so thin. There are several methods of drawing the nut together, but they have all the same objections as the above—that is, they are not effective in the entire length, and the nut must be pressed so very hard on the screw as to make the working of the tangent very tense, especially in cold weather. Another and the last method has been to apply a long spiral spring between the nut and the head of the screw that acts as the finger-piece, thus pressing the nut and the screw from each other, and consequently removing all “lost motion” from the screw. This plan, though in theory very good, in practice has been found inoperative, for the following reason: the spiral spring had of necessity to be made long enough, and stiff enough, to act in every portion of the screw’s length, the alternate opening and closing of the spring by use weakened it, and in a short time it failed to remove the “back play.” To get rid of this defect of “lost motion” in the tangent screw, opposing or butting screws have been sometimes substituted, but in use they do not give satisfaction, as two hands must be employed in using them, and standing from the edge of the plate, they are liable to be injured by blows, and they are apt, unless very carefully used, to throw the instrument out of level.

In this instrument we have an improved tangent screw, that, no matter how much the screw may wear by use or time, will never get “lost motion,” but will instantly obey the slightest touch of the hand: this is effected by means of a long cylinder nut, from the interior of which two-thirds of the screw have been removed; into half the recess thus left in the nut, is nicely fitted a cylindrical “follower,” with the same length of screw thread as the nut; this follower is fitted with a “key,” that prevents it turning in the recess, but allows motion in the direction of its length. A strong spiral spring is placed in the remaining half of the recess, between the fixed nut and the movable follower, and the spring has always tension enough to force the follower and fixed thread in contrary directions, and thus to remove any “lost motion” that may occur in the screw. It will be observed that in this method, the spring always remains in a state of rest, instead of closing and opening, as has been the case in all other applica-

tions of springs, and which have been the cause of their failure. Tangent screws that have had as much as 10' play have been made to work entirely taut by this method.

The mode of attaching the tangent screw to the plates in this instrument is entirely new; it is a miniature modification of the "Gimbelling" of a ship's compass, and allows the tangent screw, by its free swivelling, to be tangent to the plates in every part of its length, and thus never to bind. This tangent screw is also of value for sextants, astronomical instruments, etc., where "lost motion" is detrimental, and a smooth, easy motion is required. In all instruments the brass cheeks in which the three legs of the tripod play are fastened to the lower parallel plate by a number of small screws, commonly twelve. When the legs wear in the cheeks and become unsteady, the only method the Engineer has of tightening the legs is by drawing the cheeks in which the leg moves by means of the bolt that passes through the leg; this of necessity draws the cheeks out of perpendicularity, and strains the small screws that bind the cheeks to the parallel plate so much as frequently to loosen them. This source of instrumental error hardly, if ever, occurs to the Engineer, but very good instruments have been condemned as unsteady, when an examination has shown the fault to be the above. This source of error can never occur in this instrument, as the cheeks and the parallel plate are made in one solid piece. But to come to the last and most serious evil. The effective power of the Telescope is impaired by spherical aberration; that is, the field of view, as seen in the Telescope, is not a perfect plane or flat, but is spherical. To prove this, take an ordinary telescope and focus it so that an object will be clearly defined at the intersection of the cross hairs or the centre of the field of view; then, by means of the tangent screw, bring the same object to the edge of the field of view, and it will be found in every case to be indistinct and not in focus; on the contrary, focus it so as to be distinct at the edge, and it will be indistinct when brought to the centre. In some telescopes, however, it is impossible to focus at the outer edge of the field, and objects will be tinged with prismatic colors, showing that these glasses are affected by chromatic aberration also; sometimes the cause of this defect lies in the object glass, but in the majority of cases the lenses composing the eye-piece are in fault.

These aberrations affect the working of the telescope in several ways. First, it practically diminishes the size of the object glass, and the view is never so clear and distinct as it ought to be. Second, it is very difficult, and in some cases almost impossible, to adjust the eye-piece to prevent parallax, or "travelling" of the cross wires, when the eye is shifted from side to side; and practical Engineers know what a sharper power of defining and how much less trying to the eyes a "soft glass" has—that is, one that has a "flat field." This defect has prevented the general use of the Stadia, or Micrometer wires, as a method of measuring distances without a chain, as the two horizontal hairs that are used, being in different parts of the field of view, cannot, in a majority of cases, be focussed so as to be devoid of parallax, and the slightest travelling of the wires in this operation will give an erroneous result. The evils of this defect were most forcibly brought to Mr. Heller and the late Wm. J. Young's notice when one of their best Transits failed to define in tunnel work, from loss of light, from this cause; and they both endeavored, to within a short time of Mr. Young's death, to remedy it, trying all the known formulæ of almost all the opticians in the country, but without any good results. In the Telescope of this instrument these evils are entirely removed by the employment of a new eye-piece, and advantage has been taken of the improvements that Optics have made in the last few years in the curvatures and arrangements of the lenses that compose it; and the test referred to above, of focussing an object in the centre of the field of view and then bringing the same object to the edge, and it still remaining in sharp focus, can be done with this telescope, and the object shows no tinge of prismatic color, showing that both chromatic and spherical aberration have been removed.

The advantages of this improved Telescope are: a clear and sharply defined field of view; a field of view so flat that the cross hairs are without parallax in every part of it, and micrometer hairs or Stadia can be used with favorable results. The whole effective power of the object glass being used and none of the light lost, work can be commenced earlier in the morning and continued later in the afternoon than is usual. This, in the winter season, is no slight matter to the engineer; and lastly, there is no straining of the eyes in sighting. The spider's web, by reason of its fineness, is the only article hitherto used for cross hairs, yet in use these have been attended with some difficulties: first, the spider's web is hygrometric, or is affected by the humidity of the atmosphere—when exposed to dampness lengthening, and of course throwing the line of collimation from its true place. This defect is more serious in the Engineer's Levelling Instrument than in the Transit, instances being known where the line of

collimation has altered two or three times in the course of ten hours by reason of atmospheric changes, and of course any observation taken at those times would be defective; lastly, the spider's web being a transparent and not an opaque substance, in some positions it is impossible to see the hairs at all: this is more especially the case when sighting in the direction of the sun—that is, an easterly course in the forenoon, or westerly in the afternoon. To remedy this defect, platina cross hairs  $\frac{1}{1000}$  of an inch in thickness, or as fine as spiders' web, are substituted; these being opaque, and not transparent, in sighting in the direction of the sun are still visible, and any atmospheric changes, dampness, etc., do not affect them. They believe that they are the first ones in this country who have drawn wire so thin, and the only ones who have made any practical use of Dr. Wollaston's experiment. The platina hairs are invaluable in Mining and Tunnelling Instruments, that are so constantly exposed to dampness, and being opaque, no reflector to illuminate the cross wires is required.

To prevent the stiffness of working of the levelling, tangent and other screws in cold weather, which arises from the congealing of the grease that is used in lubricating them, no oil is used upon the screws of this instrument, but they are lubricated with pure plumbago.

By a simple arrangement of the clamps on the axle of their complete Transits, they make them also answer the purpose of a pair of Compass sights, for taking offsets at right angles to the telescope.

From the above, it will be seen that this instrument has the following improvements over the ordinary Transit: 1. A simple, secure and steady method of attaching and detaching from the tripod, being the only long-centre transit made that detaches as easily as a short centre. 2. An important decrease of weight, without decrease of size, and an increase of steadiness. 3. All the working parts of the tangent screw, etc., brought within the plates, making the instrument more compact. 4. An improved tangent screw, telescope, cross hairs and tripod head. 5. A pair of sights for taking offsets; and 6. A new method of lubricating the screws.

## REPORT OF COMMITTEE OF CIVIL ENGINEERS APPOINTED BY THE FRANKLIN INSTITUTE TO EXAMINE A NEW TRANSIT INSTRUMENT.

No. 863.

HALL OF THE FRANKLIN INSTITUTE,  
Philadelphia, December 18, 1871.

The Committee on Science and the Arts constituted by the Franklin Institute of the State of Pennsylvania for the promotion of the Mechanic Arts, to whom was referred for examination the Transit instrument made by Messrs. Heller & Brightly, of No. 33 N. Seventh Street, Philadelphia,

### R E P O R T

That the instrument exhibits the best of workmanship, and combines several novelties of construction which, in the opinion of the Committee, render it superior to those now in common use. Among these novelties are, 1st. A great reduction of weight, without any loss of strength or steadiness. 2d. An improved method of attaching and detaching the instrument to and from the tripod head. 3d. All the working parts of the tangent-screw, etc., are brought within the circumference of the plates, thus diminishing liability to injury, and at the same time making the instrument more compact. 4th. An improved tangent-screw. 5th. Cross-wires of platina instead of spiders' web. 6th. A pair of sights placed in the standards, by means of which a right angle can at all times be laid off from the line of the telescope; this is very useful for taking offsets from the line of survey. 7th. An improved telescope. 8th. A shifting or extension tripod leg, for use in mining or other contracted workings. 9th. The brass cheeks for the legs and the tripod head are cast in one piece. 10th. An improved lubricator for the screws.

The following is a detailed description of the above-enumerated improvements:

First. The weight is reduced to about one-half that of an instrument of the same size, made in the usual way, by ribbing and bracing the plates, etc.; and all metal that does not impart either strength or steadiness is removed, the size of the instrument not being reduced thereby in any part.

Second. The method of attaching the instrument to and detaching it from the tripod head is as follows: The upper parallel plate of the tripod head has two (2) fixed and one (1) movable lug on its upper surface. These three (3) lugs are placed equidistant from each other. There is also a flange on the exterior of the socket which encloses the centres. Three (3) recesses on the edge of this flange allow the flange itself, to lie on the parallel plate and to enclose the lugs. The whole instrument is now turned until the lugs are outside of the recesses, and the whole is then clamped by the milled head-screw of the movable lug. By this process a three- (3) pointed clamp is obtained. A forked guide-piece fitting into a groove in the clamp-screw and traveling with it prevents its being screwed out and lost.

Third. An examination of the instrument renders this third point so obvious as to require no explanation.

Fourth. The tangent-screw is constructed so as to overcome all lost motion in the following manner: A long cylindrical nut has two-thirds of its screw-thread removed. In one-half of the recess thus formed is fitted a cylindrical follower, with a key which prevents its rotation, but permits it to move forward or back. A spiral spring is placed in the other half of the recess, the tension of which forces the fixed thread and follower in contrary directions.

Fifth. The platina cross-wires (1000 of an inch in thickness, or as thin as ordinary spiders' web) prevent the sagging which the spiders' web undergoes from dampness. Not being transparent, they can be easily seen when sighting toward a light. This is an advantage when looking toward the sun, or when locating a meridian line by means of the North star.

Sixth. A pair of right-angle sights is obtained in the following way: The slits in the clamps on the axis of the telescope are extended downward so as to reach almost to the bottom of the clamps, and in these slits the sighting-holes are made. The slits are then adjusted by the knacker to cut a right angle, and index marks are then made on the clamps and standards. By bringing the index marks to coincide, an accurate sight at right angles to the telescope is had.

Seventh. The curvatures and distances of the lenses composing the eye-piece are so arranged as to overcome all spherical and chromatic aberration in the telescope. The spherical aberration of the ordinary telescope has prevented satisfactory results from Stadia measurements.

Eighth. The shifting tripod leg has a play of from three (3) to five (5) feet. It is composed of two (2) semi-circular cylinders, sliding one on the other on their plane surfaces, as in a levelling-rod, and clamping in any position. This leg dispenses with eccentrics, and will slide easily and clamp well, even if the wood of the halves be swollen or warped.

Ninth. Having the tripod head and the cheeks for the legs in one piece prevents the possibility of any unsteadiness from the loosening of the cheeks from tightening the legs.

Tenth. Pure plumbago is used as a lubricator for all the screws, preventing hard working in cold weather.

The side adjustment on the standard, by which one end of the axis of the telescope may be raised or lowered in order to make the vertical hair lie in a vertical plane through the axis, and the nice balancing of the telescope upon its centre of gravity, are also noticed as very important features in engineers' transits. There is, however, no claim to novelty in the application of these principles.

The ribbing of the instrument is judiciously placed, and the metal of which all castings are made is bell, instead of the ordinary brass. The Committee see no reason why it should not keep its adjustments and maintain its steadiness at least as well as any other. To solve all doubts, however, on this subject, letters were addressed to two engineers who had been using the transits of Messrs. Heller & Brightly almost daily for six (6) months. Both were engaged in operations requiring the best instruments—viz., one in city street locations, and one in a tunnel nearly four thousand feet in length. The answers of both were satisfactory in the highest degree, pronouncing said instruments superior to any they had ever used.

The substitution of platina wire for spiders' web was found to be especially advantageous in tunnel work, by contributing in an appreciable degree to the accuracy so necessary in that kind of work or in mining.

In conclusion, the Committee express themselves highly pleased with the instruments of Messrs. Heller & Brightly, and consider it but a simple act of justice to these gentlemen to say that, in its opinion, the deviations which they have made from the



common styles of transit are decided improvements. It may not be amiss to add that their instruments cost no more than those of the ordinary style of our best makers.

JOHN C. TRAUTWINE, *Chairman*.  
CHARLES S. CLOSE,  
LEWIS M. HOUPY,  
SAMUEL L. SMEDLEY,  
ELLWOOD MORRIS.

By order of the Committee.  
D. S. HOLMAN, *Actuary*.

The following are the two letters of inquiry referred to by the Franklin Institute Committee in their report. The letters to which these are the answers had, among other inquiries, the following:—Is the instrument steady? Does it keep its adjustment? if not, how frequently has it been adjusted since you first received it?

BURLINGTON, N. J., October 28, 1871.

**MESSRS. HELLER & BRIGHTLY, PHILADELPHIA:**

GENTLEMEN:—Your inquiries regarding the Transit purchased of you last spring is at hand.

I am happy to say that when put to test of unremitting use for several months with constant and critical examination during the entire period for the discovery of faults that are ordinarily supposed to exist, I have not been able to detect anything amiss.

Besides using the Transit for the customary purposes of a general practice, I have employed it in the careful reorganization and rectification of the Surveys of our city, and the preparation of a *strictly accurate* Atlas, similar to that which is in use in the Survey Department of Philadelphia; and in two very essential respects I have found it superior to any other that I have ever known; I refer to stability and permanance of adjustment.

I have frequently left it standing in one position for hours, and on my return found the telescope maintaining the same line with entire exactness; and in point of adjustment, it is as correct and reliable to-day as it was after the searching examination you gave it in my presence on the day of its delivery to me.

The graduation of the plates is exceedingly accurate, and in that respect my Transit is superior to the majority of those in common use; in fact, the results obtained from its use have been such that had they not been frequently repeated with equal success, should have been attributed to chance.

The needle, too, is excellent in all the essential particulars of straightness, correct centring and magnetic power. In perhaps a hundred readings of angles by the needle as compared with the readings of the vernier, in no one has the difference amounted to more than three minutes.

I am yours, etc.,

H. S. HAINES.

OFFICE OF THE LEHIGH COAL AND NAVIGATION COMPANY,  
NESQUEHONING TUNNEL, PA., November 1, 1871.

**MESSRS. HELLER & BRIGHTLY, PHILA.:**

DEAR SIR:—Your favor of 28th ult., inquiring about the instrument made for use on this work, is received.

The instrument has proven entirely satisfactory in every respect;—it is perfectly steady—it keeps its adjustment admirably, it not having been touched in this respect since it came from your shop, and is now perfectly correct.

The platina hairs have never shown the least indication of sagging from the moisture of inside work; and they are the only hairs that we have not had trouble with in this respect;—the instrument has frequently been in the dampness of a Tunnel for hours at a time. . . .

We were enabled to bring our lines together with your instrument with a lateral variation of  $1\frac{1}{4}$  inches in a Tunnel 3800 feet long.

We have found another great advantage in the use of the platina: namely, that when the light is reflected on them by a lamp, instead of the indistinct line which the spider web gives, we have a clearly defined black mark.

Yours, etc.,

THOS. C. STEELE, Engineer.

**HELLER & BRIGHTLY'S IMPROVED TELESCOPE.**

(From the editorial columns of the U. S. Railroad and Mining Register, Jan. 10, 1874.)

**Improved Transit Telescope.**

Every improvement in engineering instruments is of consequence; and the very great increase of power gained by Messrs. Heller & Brightly in their new telescope, as described in their letter and accompanying circulars given below, is of sufficient importance to attract the immediate attention of every engineer:

PHILADELPHIA, January 7, 1874.

*Editor U. S. R. and Mining Register:*

DEAR SIR:—Having just brought to a successful conclusion a series of optical experiments, having for their object the increasing the power and range of the ordinary telescope, and knowing the interest you take in any improvement of field instruments, we enclose you the results we have arrived at. An ordinary Transit Telescope, 10 inches long, magnifies 12 diameters; an ordinary Level Telescope, 17 inches long, magnifies 25 diameters. Without any increase of length, our new Transit Telescope magnifies 28, and the new Level 48 diameters—in other words, without any increase of length, we give the Transit Telescope more power than a regular Level Telescope has. We have lately furnished the Survey Department of Philadelphia with a Transit for use at the “new South Street Bridge,” and the engineer in charge there has been making some tests of the power and range of the new telescope as compared with another very good telescope made in the ordinary way. A copy of his letter we enclose. While making the tests the instruments were placed side by side and seen through, at the same time, in order that any atmospheric unfavorableness should affect both equally. We think, however, that the first test should read, “set a  $\frac{1}{2}$  inch flag” (instead of  $\frac{3}{4}$ ), as the  $\frac{1}{2}$  inch white space was the object sighted at, and the black only marking the boundaries of the white. As to the extreme range of the telescope, the enclosed extract from the Fairmount Park Engineers, may give some idea. Yours, &c.,

**HELLER & BRIGHTLY, 33 North Seventh Street.**

[COPY.]

ENGINEERS' OFFICE, SOUTH STREET BRIDGE,  
PHILADELPHIA, December 22, 1873.

DEAR MR. HELLER:—I have just finished some very satisfactory tests of the new Transit you lately sent me—and knowing that a statement of the results would be as gratifying to you as it was to me, I send it to you in detail. The Transit with which I compared the power of yours, was made by the late Wm. J. Young, for Strickland Kneass, Esq., when the latter was Chief Engineer and Surveyor of the city, the instrument is considered a very good one of its kind:

Set a flag, $\frac{3}{4}$ inch wide, accurately.....	W. J. Young.	Heller & Brightly.
Could just see hands on a watch—very dimly.....	450 feet.	1,535 feet.
Read time within one minute.....	212 feet.	1,231 feet.
	180 feet.	983 feet.

The “flag” test was on a target made of paper, with three  $\frac{1}{2}$  inch stripes, two black and a centre one of white. This target was sent off until the *white* stripe was just barely discernible. The watch used was a “Tobias” make,  $1\frac{1}{2}$  inch diameter of dial, face white, and hands 1-50th of an inch wide at ends. On the first “watch” test, it was sent off until I could merely tell that there were hands on the dial. At the second test I read the time within about one minute. The length of telescope in the Young Transit is 10.8 inches, and in yours 10.7 inches when both are focussed on the same object.

Yours, &amp;c.,

D. M. STAUFFER.

[EXTRACT.]

FAIRMOUNT PARK, December 6, 1873.

MESSRS. HELLER & BRIGHTLY:—At your request I tested the power and range of your new telescope. On account of the haziness of the atmosphere the day was unfavorable. As to range, from sights taken at Falls of Schuylkill in direction of Conshohocken, I could see and locate a flag staff at about seven miles.

THOMAS G. JANVIER,  
Assistant Engineer, Fairmount Park.

As the following letter from the editorial columns of the Railroad and Mining Register gives the manner by which we have increased the power of our Telescopes, we give it in full. It is in answer to a correspondent who, seeing the above article giving the comparative tests of our new Telescope as compared with an ordinary one, asks for information on some points mentioned in it that were not perfectly clear to him.

First, not knowing the means by which we increased our power, he of course imagined that we used the old "regular formula," such as had been used and abandoned for high powers years ago; inquiry is also made, whether the "Kneass Transit" was a fair sample of the ordinary Telescope; and if the powers of the regular Telescope, as made at present, might not be sufficient for ordinary purposes. The correspondent was also under the impression that the magnifying power of an ordinary Telescope was somewhat higher than we had stated. The correspondent not taking into consideration that the day of trial was one of the shortest and darkest of the whole year (December 22), thought very naturally that the flag might have been seen at a greater distance than it was (1535 feet); seeing that time was read on a watch-dial at 983 feet. Mr. Stauffer's letter explains this.

(From the editorial columns of the "United States Railroad and Mining Register" for January 31, 1874.)

*To the Editor of the U. S. R. R. & Mining Register:*

DEAR SIR:—The correspondence in your issue of the 17th inst., criticising the tests and results of the trial of our "new Transit Telescope," calls for some notice from us. The complaint of want of power in the glasses of field instruments is no new thing, when Richard B. Osborne, Esq., some years since endeavored to introduce the American form of Transit into England, the want of power in the telescope was the principal objection urged against it (the European telescopes of the same length being much more powerful than those used in this country, from the fact that the "inverting" telescope is almost exclusively used there). Our Mr. Heller, who for fifteen years continuously was connected with the late Wm. J. Young in business (for a greater portion of it as a partner, under the firm name of Wm. J. Young & Co.), and Wm. J. Young, were well aware of this want of power, and labored together for several years previous to Mr. Young's death to correct it, but without success, and up to the date of his decease (July, 1870), the formula for their telescopes was practically the same as had been used for at least fifteen years before. The "City Transit," with which our "improved Transit Telescope" was compared by Mr. Stauffer, was known in their manufactory as "Kneass Transit," and was used by the city during his entire term; and although the other parts of the instrument were somewhat worn, the telescope was considered good. To prove, however, if the telescope of the "Kneass" instrument was a fair sample of its class, we having in our establishment at the present time two Transits for repairs, that are of the make mentioned by your correspondent, but made within the last few years—the telescopes of these are respectively 11 and 12 inches long, and time was read on a watch similar to the one used in the last test at 195 and 210 feet, showing that taking the lengths of telescopes into consideration they are not superior in power to the one with which Mr. Stauffer experimented. As regards the statement of your correspondent in reference to the powers of Transit Telescopes of various modern makers, we would remark that one fact respecting telescopes must be taken into consideration; i. e. that the calculated magnifying power and their actual performance in the field are sometimes sadly at variance; we now have in our possession for repairs a Transit made in New York City, the nominal magnifying power of which is 15 diameters, yet it is impossible in consequence of its poor defining power) with it to set an ordinary flag-pole accurately at the distance of 300 feet. Although the "achromatic, compound lens," eye-piece of Kellner or a similar combination, has been of late years adopted in Europe for fine telescopes, still from its great expense, and the objection of American engineers to an "inverting" telescope, it has been comparatively unknown here; the United States Coast Survey Department use it almost exclusively on all their new instruments.

Your correspondent states that the same combination of lenses that is in the "improved telescope" was known "years and years ago;" we think he must be mistaken. Mr. Young and Mr. Heller, during their extensive experiments and researches referred to above, knew nothing of it, and so lately did we bring our own experiments

to a successful conclusion that, although we have lately (1872 and 1873) furnished the Survey Department of this city with Transits for the new bridges now in the course of erection over the Schuylkill at Girard Avenue, Fairmount and South Street, none except the last has the new telescope—in fact, so very recently have we ourselves adopted it that, although we receive orders from the University of Pennsylvania to spare no expense or pains to make the equipment of field instruments for the new Department of Science as perfect as possible, we did not insert it in their field instruments. In referring to Transit Telescopes, we of course mean such as are in common use by engineers, from 10 to 12 inches long, capable of reversing their standards both at eye and object ends, and showing objects erect, instead of inverted—those for special purposes of extra power and length (we have made them 20 inches long) and with “inverting” telescopes, we do not class as ordinary ones. We have never made any secret of the mode by which we increase the power of our telescopes. The improvement consists in our availing ourselves of the formula of Kellner, with the addition in our telescopes of the two extra lenses necessary for producing an erect image. If your correspondent will do us the pleasure to call on us, we shall be happy to show him the numerous experiments we have made, and the results; he can also examine the two instruments mentioned above at any time. If we have caused any engineer to think seriously on a subject which he has heretofore taken mainly on trust (i. e., the power of his telescope), he will find the subject repay investigation. If engineers will call on us, we will with pleasure show them the new telescope and let them judge for themselves; or if a committee of the American Society of Civil Engineers (or any kindred body) would like to make a thorough trial, we will furnish them with the means. As to the remarks of your correspondent denying the desirability of an increase of power, we think that the majority of engineers differ from him in opinion, and any one who has stood with watering eyes endeavoring to accurately set a flag at a moderate distance, will agree with us that a Transit Telescope with the power of a Level Telescope is a gain, and that the opinion of such men as John C. Trautwine, Eckley B. Coxe, Richard B. Osborne and R. P. Rothwell, that the new telescope is “a most important and useful improvement,” is entitled to some weight. If it were not against our rule to publish correspondence, we could give letters from parties of weight in the engineering profession which would, more strongly than anything we could say, corroborate what we have written—in fact, we have obeyed our repugnance so far that we have for two years refrained from publishing an exhaustive report of a committee of civil engineers appointed to examine the new Transit which we introduced at that time, although the favorable opinion of such men as John C. Trautwine, Elwood Morris, L. M. Haupt, Samuel L. Smedley and Charles S. Close might be thought of some value. In conclusion, we are sorry that a friendly private letter, giving you information that might interest you, and not intended for publication, but which you thought contained matter of interest sufficient to warrant publishing, should have caused your correspondent's letter. In the hands of the engineers we now leave the matter; if we have made an improvement, it will speak for itself. We merely repeat our invitation to engineers, instrument makers, etc., who feel desirous to test this matter for themselves to call upon us; we will freely communicate to such any information in our possession. Yours, etc.,

HELLER & BRIGHTLY, 33 North Seventh Street.

January 22, 1874.

ENGINEERS' OFFICE, SOUTH STREET BRIDGE,  
PHILADELPHIA, JANUARY 22, 1874.

To the Editor of the U. S. R. R. & Mining Register:

DEAR SIR:—A word of explanation may be necessary to explain away a seeming discrepancy pointed out by your correspondent of January 17th, in his criticism on the performance of Mr. Heller's New Telescope, lately tested by me. The test results were communicated to Mr. Heller in a friendly letter, not intended for publication, or I should have been more explicit in my explanation. The Transits were tested side by side, and at the same time, so that any local influence would have been felt by both. But the first test was made on the flag about 9 A. M., with the sun obscured by clouds, and in an atmosphere decidedly hazy, with the flag located in a depression of South Street, the worst point for an observation. The watch test was made more than three hours after, when the sun was shining brightly and all haziness removed; had I then again tried the flag, I have no doubt the results would have been more favorable than stated. Yours, etc.,

D. M. STAUFFER.

## STROLL THROUGH AN ENGINEERS' INSTRUMENT MANUFACTORY.

Having recently visited some of the establishments of our "Engineering and Surveying Instrument Makers," we became possessed of some facts which may be of interest to general readers, and also showing the immense development of this branch of industry since the early days when the Drapers, Rittenhouses and Stancliffes gave to Philadelphia mechanics their pre-eminence in the manufacture of these "instruments of precision."

But the staid plodding artisans of those days would be amazed if they could see the revolution that time has made in the details of their whilom business—the intricate machinery (one of the old establishments, with all its tools, not costing as much as one first class modern lathe with all its appurtenances), the appliance of steam, graduating engines, and the vast range it has taken in its various details.

On our list we will first take the well-known establishment of the Messrs. Heller & Brightly, and from them and their books have gleaned the facts for the following article.

The first thing to forcibly strike the stranger's attention is the widespread ramification of an establishment of reputation—in looking over their "order book," we found every State from Maine to Florida represented, and the Survey Department of almost every important city and town (the Middle and Western States predominating, however).

Orders from Japan, China, Chili, Peru, Brazil and Canada jostle each other; the order of Arinori Mori, the Japanese ambassador, for a complete set of field instruments for the "Kaitakuski of Hokaido" (whatever that may mean) stands side by side with those of the "Survey Department of Philadelphia"—Meigs, the railroad king of South America—the University of Pennsylvania—and the Centennial Building Commission—and we were shown with commendable pride a "cable telegram" order for a Transit from Hong-Kong, China, which ran thus: "One Heller, Philadelphia, send Transit Instrument like General Capron's."

The greater part of their business, like that of the majority of those in the same line, is however with the railroads; and this need not be a surprise to any one, the Pennsylvania Railroad and its numerous branches alone using up enough instruments, to keep a respectable sized manufactory constantly employed.

The Survey Departments of cities must also be constant consumers, judging from the fact that that of Philadelphia alone ordered 8 instruments within the last two years.

We were curious to learn if, in sending their wares to every point of the compass in this manner, whether they ever had trouble in receiving the money for the same; and for the character of the Civil Engineers as a class, we were proud to hear that they have yet to make the first bad debt.

Great confidence must exist between the producer and consumer, for assuredly in no other business would valuable goods be sent to a perfect stranger thousands of miles away on the faith of a telegram (as happened on the day of one of our visits) worded thus—"Send Transit to lay out town site to ———, Arizona."

An instance of the credulity of human nature, and the tenacity with which a popular belief will descend from generation to generation, we learned here that somewhat surprised us.

A letter from Massachusetts received a few days before was shown us—the writer wished to be informed whether a "divining rod" "needle" or "treasure sand"—that would be attracted by hidden gold, silver or gems in the earth, in the same manner as the magnetic needle is attracted by iron—could not be purchased by him.

On our expressing surprise that in the present age of enlightenment a belief in such an article should exist, we were informed that this letter was one of a

**class.** That from 12 to 40 letters or calls were received yearly—the majority of them however were received from parties on the Atlantic coast, from Maine to New York north, and from Maryland to Florida south, and the treasures to be found were those said to have been buried by the piratical Captain Kyd (he who “sailed, sailed”).

Besides these “treasure seekers,” calls are received in more or less numbers every year for the “witch hazel divining rod” (for discovering hidden springs by divination).

The “perpetual motion” inventors have also not “perished from off the face of the earth,” judging from the number of models that are sent to Messrs. Heller & Brightly for their opinion, each of which (according to the inventor) solves the long mooted problem.

Solomon's axiom of there being “nothing new under the sun,” and the persistency with which an idea will crop out in one generation, die away and seemingly be rediscovered in another, only to meet the same fate, was shown to us in the model of a “distance measurer” that had shortly before been received—and which the inventor thought was entirely original, and his fortune of course secured. Those who have delved in the old volumes of the various mechanics' magazines—the proceedings of the various scientific societies—or the back numbers of the patent office reports, may recollect the “Monsieur Tonson” that was ever turning up, in the shape of a “distance measurer” (an instrument by means of which the distance of any far object could be ascertained without the tedious process of chaining), in which, though the details might have been varied, the principle underlying them all was the same (*i. e.*, a fixed Telescope or vane sights placed at right angles to, and at one end of a base more or less long, generally from 2 to 3 feet, a second Telescope movable along this base, and this Telescope slightly inclined toward the first one—the movable Telescope being slid along the base until the line of sight of both it and the fixed one cut the same object. The distance of the object from the instrument being then read off from a scale on the base). This same instrument in various forms is as old as Archimedes at least. The fatal defect of the instrument is that the base necessarily being short, and the angle formed by the two Telescopes consequently being too acute for accuracy. During the late war we were informed that at least thirty applications for patents had been made for an instrument of this class, all having the above idea, and each patentee imagining himself the original discoverer.

Knowing from experience how very poorly, some twenty years ago, the institutions that made a specialty of teaching Civil Engineering were supplied with field instruments, and the inferior character of those they did have, we were curious to know whether this state of affairs continued, and were most agreeably surprised at the change we found.

The “order book” was again brought in requisition to answer our queries. First, our attention was directed to the list of instruments and their character furnished the new “Department of Science” of the venerable University of Pennsylvania.

Besides the usual Transits, Levels, Compasses, Sextants—we found such comparatively modern costly “instruments of precision” as the Solar Transit, Plane Table, etc.,—in fact, the sum total of their outlay for instruments alone would have appalled some of the other institutions; and the orders for field instruments from colleges situated where twenty years back naught but forests flourished—was a striking proof of the tremendous strides the country has made since then.

*En passant*, we were somewhat amused during one of our visits. A graduate of a so-called “college,” having received a situation on a railroad, came to purchase a Transit Instrument.—One was shown him such as is used for city work. The vernier reading of the horizontal limb, however, was not close enough for him—half minutes being entirely too inexact, and nothing but a ten second (10'') subdivision answering.—His dogmatical assertions that a half minute (30'') reading might answer for common work, such as running a straight line or turning a right angle, but not for deflecting for railroad surveys, was amusing; as was also his blank look of astonishment and doubt when informed that two of the most

difficult of his field operations, would be those very two that he treated so cavalierly, (namely, turning, a precise right angle and establishing a straight line).

We were informed, in answer to queries, that the most elaborate and accurate instruments, without regard to cost, were demanded, as a general rule, by the Mining Engineers of Lake Superior.—These were followed by the Survey Departments of the various cities—the Mining Engineers of Colorado, California and this State came next.

Judging, however, from the minuteness of detail and seeming disregard as to cost of some orders on their books from Engineers who have made Bridge Building and Tunnelling a specialty, the precision requisite for such work must require the best instruments.

To the curious spectator the several details of the manufacture—the graduating engines—the patient exactness required of the workmen (one of their proverbs being that Job would most assuredly have lost his patience, had he belonged to their craft)—are matters of surprise, and where in the finished instrument all the parts he had seen in detail could be placed would perplex him (a complete Engineer's Transit with all its belongings numbering 362 separate parts).

To an engineer, who, knowing the longevity of a Transit, and the comparatively small class by whom they are used, and seeing the number of instruments turned out of an establishment of this class—they just finishing at the time of our visit 50 Transits, and commencing 100 more—knowing that this process was continued through the entire year, and that this was only one of numerous similar establishments—the one absorbing question to him would be (as it was to us), What becomes of all the Transits?—and the answer to which would be as hard to give as to the other equally celebrated one, "What becomes of all the pins?"—(*Engineer*, March, 1874.)

## MODERN PRACTICE OF FIELD-WORK IN RAILROAD SURVEYS, BY RICHARD B. OSBORNE, CIVIL ENGINEER.

GIRARD HOUSE, October 6, 1873.

MR. CHARLES S. HELLER, PHILADELPHIA:

DEAR SIR:—You have asked me to state in what I consider your improved Transit with its vertical arc superior as a field instrument to the ordinary plain field Transit.

When an Engineer is entrusted with the location of a railroad, his first inquiry should be,—what is it intended to transport? and having learned the quantity and quality of traffic *each way*, and made a reconnoissance of the general route, and ascertained the impediments to be overcome in the location of the line, he can at once determine on the *ruling gradient* and a maximum load for a given weight of Engine.

He will find, perhaps, that a part of the line will be over gently undulating ground, while other parts will be through a mountainous country.

According to the length of time through these different kinds of land, the number of Transits of each description required can be obtained.

For the first, or easy country, the plain Transit is the best, as a little more portable and less costly.

For the mountains, none but the Transit with its fine improved telescope and *vertical arc* should be chosen.

Experience has taught me that the most economic, accurate, expeditious and successful work is done when well-tried principles and systematic plans control the operations. "Rule-of-thumb" work seldom succeeds; the good results even in close Engineering work have been attained by a bold dash based only on clear judgment—clear, I mean, to the mind using it.

The old system of "trial and error" lines is unfit for our profession now; we

have taught the whole world all they know about location of railroads, and we should advance.

When the Engineer, either by the barometer or by "flying levels," approximately ascertains the elevations of the highest summits he has to overcome, as well as the *distances* (the other elements for making out his grades), he can determine on the **ruling gradient**, which will then determine his *maximum load*.

Experience should teach us that it is inexpedient, if not wrong, as a general rule, to *spend large sums* of money to reduce gradients at *other points* of the line *below* the **ruling gradient**, because it will not financially benefit the working capabilities of the Engines, whose maximum load is already controlled.

With such fixed data in his mind, the Engineer can view in a ride the easy country, where a line generally can be at once *located*, without any experimental survey, by the eye and judgment, because the grades, being all less than the **ruling grade** over the mountains, can have the grades fitted to the country over which the maximum loads can be taken.

For such work the *plain Transit is best adapted*.

But in a country which presents mountain ranges that must be crossed, the case is *wholly different*.

Each ridge should be explored, and the elevation of its lowest available summit obtained, also the distances by time, or the pedometer, and thus the required gradient be worked out.

Then the Transit with its **vertical arc is indispensable**.

Its utility consists in perfecting with *one* experimental line, which it **vividly points out by its valuable adjunct, the vertical arc**, the exact position of the *best location* that can be made on the ground of **uniform grade**, with the **least work**. By it the exact profile of a located line can be had, on which I have even let work to contractors *before* the *field location* was made.

Hundreds of thousands of dollars would have been saved, if this had been in use in the last twenty years, the work too would have been better done, and trains would be able to mount to many summits with more ease than they now do.

**Here is the modus operandi** in explanation, and Engineers who keep the old method will see that mountain surveys, which are tedious and laborious, are thus made easy and agreeable.

**The Engineer, knowing then the average grade that will carry the line to the summit with a given cutting at that point, sets, before starting, his vertical arc to the angle corresponding to said grade.**

A flag on a pole the height of the Transit Telescope from the ground is taken ahead by the Engineer in charge, as far as *he can be seen by the Transit*, and with his judgment aided by the pocket level he gets approximately in position, so that all clearing can be done while the Transit is moving up and getting set on last transfer-point.

The Transit then sets the grade flag accurately, and the chaining is done to the grade flag, when the exact transfer point is set, **which is grade**.

On this the Transit moves, and thus continues till the summit is reached by a **true grade line**.

Cross sections with the clinometer are taken at every 100 feet station, well to right and left, where the angles are great, when that portion of the line is ready for plotting, on which the located line can be planned, the centres being all at **grade**.

The line can be straightened, curves introduced—profile made out, and in the office a tale will be fully told of all the characteristics of the future location.

Thus two quickly run lines will fit the contour of the mountain, with work just as light or heavy as the Engineer may select to give him the **best line** that can be put on the ground.

But in other ways the Transit arc is of great use.

Here is one example:

To test a line advancing toward a high summit when 8 miles from it, I once had a flying level run from the summit to a point at *the foot of a tall pine* 5 miles from the summit.

I converted this tall pine, by the *vertical arc*, into a levelling staff, and using it



as a *back rod*, transferred the level to the mountain side, high over the valley, where I fixed a point which the advancing line should pass through, so as to reach the summit with a fixed cutting thereat and on the ruling grade.

It worked to a *charm*, and my *grade came* out to a nicety.

I would as soon send a party into the field without a *chain* under such circumstances as I would without a *Transit* with your vertical arc.

These are its uses in survey work.

In construction it is a most desirable instrument, as the assistant needs but one instrument, which is both *Transit* and *Level*, which is a great desideratum.

I am, yours truly,

RICHARD B. OSBORN.

### ON A NEW MINING TRANSIT AND PLUMMET LAMP.

(From Van Nostrand's Engineering Magazine for June, 1873.)

A communication to the American Institute of Mining Engineers, at the Boston meeting, February 19, 1873, by Prof. R. W. Raymond, President of the Institute:

Having had recently the opportunity of examining a *Transit* and a *Plummet Lamp*, manufactured by Messrs. Heller & Brightly, of Philadelphia, and intended for the use of mining engineers in underground surveying, I thought a description of them would be interesting to such of our members as have work of that kind to do, and accordingly I requested the makers to prepare and send to me a detailed account. There is nothing specially novel, I may remark, in the construction of the *Transit*; its claims to favor must rest upon its compactness and lightness, together with the general excellence of its workmanship. The principal peculiarity is the ribbing and flanging of the parts requiring strength, so as to dispose the minimum amount of material where it will secure the greatest rigidity. This *Transit* is said to be the lightest of American make. I believe Caselli has sent some from London which are still lighter; but they are perhaps not so completely furnished for field-work. I confess I do not see how the weight can well be reduced any further, unless an instrument can be made of aluminium—a plan which Mr. Rothwell once suggested; but which may not, perhaps, be entirely practicable, and, at any rate, has not been tried.

The following is the manufacturers' description of this *Transit*, which they have designed and introduced within the last year:

It is a small portable angle instrument, similar in principle to the ordinary "Engineer's *Transit*," and a *fac simile* in every respect (excepting size and weight) of their "complete Engineer's *Transit*." It has long compound centres; the horizontal limb is read by two double opposite verniers, placed outside the compass box; the vernier openings in the plate being made very wide, so as to allow the easy reading of the graduations. There is a three inch magnetic needle, and its ring is divided to half degrees. The telescope is  $7\frac{1}{4}$  inches long, with object glass fifteen-sixteenths inch in aperture, and shows objects erect and not inverted. A sensitive level,  $4\frac{1}{2}$  inches long, is attached to the telescope, for reading angles of elevation and depression, levelling, etc. The tripod is furnished with an adjustable head for precise plumbing of the instrument over a centre; and the wooden legs of the tripod are made in such a manner as to form one leg when folded together. The plates, vertical circle, etc., are provided with clamps and tangent-screw movements; and the clamps on the axis of the telescope are arranged with sighting slits and indexes, so as to answer also for right angle sights. The numbering of the compass ring and horizontal limb, instead of being in quadrants from  $0^{\circ}$  to  $90^{\circ}$  each way as usual, is a continuous one, or from  $0^{\circ}$  to  $360^{\circ}$ ; but every quadrant of the horizontal limb is also marked with its magnetic bearing, *i. e.* from  $0^{\circ}$  N. to  $90^{\circ}$  E., every ten degrees is marked N. E.—from  $90^{\circ}$  E. to  $180^{\circ}$  S., every ten degrees is marked S. E., etc. The advantage of this arrangement is, that, if at starting, the vernier of the horizontal limb be set to read the same bearing as the needle, the needle can be screwed up, and both the angles and magnetic bearings read from the horizontal limb, without using the needle for the remainder of the survey, thus precluding any error from local attraction, reading from the wrong end of the needle, or loss of time in waiting for the needle to settle. The telescope, though short, is a very powerful one, magnifying and having the clearness of an ordinary 17-inch level telescope.

A reflector for illuminating the cross wires in dark places is used, as is also an extension tripod leg for lowering or raising the instrument. All the working parts of the needle-lifter, clamp and tangent screw movement are concealed between the plates, making the instrument more compact. A prism and tube for attaching to the eye-piece of the telescope, for sighting vertically in shafts, is also furnished. The weight of the instrument, exclusive of the tripod, is about  $5\frac{1}{2}$  pounds; the weight of the tripod is  $3\frac{1}{2}$  pounds; the height of the instrument from the tripod legs is 7 inches; the extreme diameter of plates, 5 inches; the diameter of the horizontal plate at the point where verniers and graduations meet,  $4\frac{1}{2}$  inches. The instrument and tripod head are packed in a box  $7\frac{1}{2}$  inches square, arranged with straps to allow its being carried over the shoulder in the same manner as an army officer's field glass, while the folded tripod legs answer as a cane. Though these instruments have been specially designed for mining use, yet from their lightness and compactness they are also meeting with favor for geological surveys, and for preliminary railroad reconnoissances; when used for these purposes, an extra pair of hairs for stadia purposes (*i. e.* measuring distances without chaining), besides the ordinary cross-hairs, is added.

The same manufacturers make a very convenient Plummet Lamp, for underground work. It consists of a brass lamp, suspended by two chains, and terminated below in a conical plummet. The so-called compensating ring is an equatorial ring, surrounding and supporting the lamp, which swings freely within it, upon an axis. The two chains are attached to this ring at the extremities of a diameter perpendicular to the axis. By means of this arrangement, the point of suspension, centre of lamp flame, and steel point of plummet always lie in a true vertical line, no matter how much the brass supporting chains may alter in length from the heating of the Lamp, kinking or wearing of the links. A shield at the top prevents the flame from burning the string. These Lamps are generally used in pairs for back and forward sights.

I understand that Mr. McNair of Hazleton and Mr. Coxe of Drifton, both members of this Institute, have used this instrument with satisfactory results.

## USE OF THE PLUMMET LAMP IN UNDERGROUND SURVEYING.

(From Van Nostrand's Engineering Magazine for July, 1873.)

A paper, read at the Boston meeting of the American Institute of the Mining Engineers, February 19, 1873, by Eckley B. Coxe:

In the anthracite coal regions of Pennsylvania the custom has been to sight either at an open light (generally a mine lamp), or at the string of a plumb-bob. If the station was intended to be a permanent one, a spud, as it is called, that is, a nail resembling a horse shoe nail, with a hole in the head, is driven into the timbers over the station, or, if there be no timber, a hole is drilled in the coal or rock roof into which a wooden plug is driven, which serves to hold the spud.

The first operation in making a survey, is to lay out the stations, that is, to mark the place where the holes are to be drilled for the points on the timbers where the spuds are to be driven in. This should be done before any instrumental work is begun, as much labor can generally be spared and the use of very short sights can often be avoided, by carefully laying out the stations beforehand. When the stations were laid out, a plumb-bob was hung from the innermost spud, which I will call No. 1, the instrument was put in position at No. 2, by plumbing down and putting a centre pin under the spud, and then setting up over the centre pin, and another plumb-bob was suspended from No. 3. If great accuracy was not required, a mine lamp was set up under the plumb-bobs at No. 1 and No. 3, and the engineer sighted at them. If great accuracy was required, a lamp or some white surface was held by an assistant behind the strings of the plumb-bobs. To work with any speed by the latter method (*i. e.*, the accurate one), it was necessary for the engineer to have three assistants on whom he could rely, even when the chaining was done afterwards, *viz.*: one to hold the light behind the string at No. 1, one at No. 3, and an assistant at the instrument to hold the light while levelling, reading the instrument, etc. When using lamps on the ground, it is necessary to examine them from time to time to see that they have not sunk in the mud or turned on one side, etc.; besides, the flame of a mine lamp is a

very large object to sight at, and sometimes it is impossible to see it on the ground (when it can be well seen two or three feet above it), in consequence of some intervening obstacles. Being so situated that it was necessary for me to do a certain amount of accurate work, where I could not rely upon having more than one competent assistant, I had the plumb-bob lamps constructed, and I work with them with a single assistant in the following manner:

When the stations have been laid out, I go to station No. 2 with the Transit, and by means of the plumb-bob belonging to the instrument, I place the centre pin, (a small block of lead with a steel pin in it,) precisely under the spud No. 2; I then remove the plumb-bob and set up my instrument. While I am doing this, my assistant takes the two lamps, suspends one from spud No. 1, and the other from spud No. 3, and then comes back to hold the light for me while I make the final adjustments and take the readings. My instrument is graduated to  $360^{\circ}$ , and has two verniers  $180^{\circ}$  apart. I set the vernier at zero, and sight backwards to lamp No. 1. The flame is very small and has a blue central cone which I bisect. I then read the compass needle, invert the telescope, deflect and sight at No. 3, and read both verniers and the needle. I then turn the telescope back, sight upon No. 1, and turn the vernier plate round nearly  $180^{\circ}$  until I sight No. 3, and again read both verniers. I obtain thus four readings of the deflection from the vernier, and a compass reading as a check, and, as the lights are steady and small, the readings can be made very accurately and quickly. If the four readings agree (with their difference of  $180^{\circ}$ ), I am sure there is no mistake and go on. I then take up my Transit, go to No. 3, run down the lamp to near the ground, put my centre pin under it, remove the lamp and begin to set up.

In the meantime, the assistant brings the lamp from No. 1 to No. 2, and then takes the lamp from No. 3 to No. 4, and comes back to No. 3 to assist me at the reading of the instrument. The work goes on in this way until all the angles are measured. I then go back and chain the distance from one station to another, and take notes of the workings, etc. In this way, two persons can make a very accurate survey as quickly as three can by the old method. Of course if one has assistants enough the chaining can go on with the instrumental work.\*

\* This paper of Mr. Coxe's and the preceding paper of Prof. Raymond's were also republished in the Engineering and Mining Journal, U. S. Railroad and Mining Register, Western Mining Review, and in the Transactions of the American Institute of Mining Engineers.

Work has been commenced on the Centennial Building, in Philadelphia. Within two days after his appointment, the engineer in charge had already broken ground. The engineer's instruments used in the surveys are of the most approved make, and are furnished by Messrs. Heller & Brightly, Philadelphia. The Telescopes on the transits and levels, made by this firm, are much superior to the old-style instruments we have been accustomed to.—*From the Engineering and Mining Journal, New York, February 14, 1874.*

The Second State Geological Survey of the State of Pennsylvania was organized at the last meeting of the Board of State Commissioners in Harrisburg, June 26th, by the adoption of by-laws and a plan of Survey presented by the State Geologist.

The rooms of the Commission in Harrisburg will at present be used, in addition to their proper use, to form the nucleus of a complete geological and mineralogical museum of the State.

The work for the remainder of the season has been organized, and by securing the most improved field instruments as proposed, much time will be saved here after and far greater accuracy attained.

All the field-instruments for the Survey are specially made for it by Messrs. Heller & Brightly, Philadelphia.—*Ibid., July 18th, 1874.*

(From the United States Railroad and Mining Register, June 28, 1873.)

### LESLEY'S MICROMETER FOR FIELD-NOTE PLOTTING.

Read before the American Philosophical Society, April 18, 1873.

I desire to place on record in the proceedings of the Society a description of my Micrometer for plotting field-notes, which appears to be coming into favor with Civil and Mining Engineers.

It was many years ago that the need of such a little instrument forced itself on my attention, as a substitute for a vernier attachment to a scale for use on the office-table. The strain upon the eyes in constant plotting on small scales, say on the common scale of 1000 feet to the inch, or the not uncommon one of 2000, is greater than the best human organs of vision can endure without permanent injury, to say nothing of the loss of time involved in adjusting the dividers, or applying the paper edge, if a paper scale be used directly. Every field worker who has constructed elaborate contour line maps covering an extensive region of country will bear me out in this assertion.

Considering also the liability to error in counting the decimals and hundredths or thousandths of the scale-unit of *distances*, after hours of application to work has lowered the tone of the nervous system, I sought some mechanical substitute analogous to Mr. Cleaver's Protractor, now in almost universal use for plotting *courses* with ease and precision.

Many forms of such an instrument passed through my mind, but over-occupation, or perhaps laziness, prevented me from taking the necessary steps to realize the idea in even tentative form, although I spoke of it several times to Mr. Young, the accomplished and experienced instrument maker of Philadelphia, now dead.

During my wanderings in Europe in search of health in 1866, 1867, and 1868, I was several times the guest of my old friend and fellow-laborer in the Anthracite coal fields (1853), Prof. Edouard Desor, at his charming residences on the Combe Varin and in Neufchatel, Switzerland. One day we strolled into the well-known philosophical instrument manufactory of Mr. Hipp, to whom, among other things, I mentioned the need of a Micrometer Divider for plotting, and drew at his request three of its possible forms, such as seemed to me the most feasible, giving him an order for one, and leaving him to select the form he preferred.

On my return to Philadelphia in the spring of 1868 I received it in a broken condition. The chain had been snapped by some custom house official, too curious to learn its nature to treat it with much delicacy of handling. It was, however, easily repaired, and I found it all I could desire: handy, accurate in its action, and perfectly relieving the eyes from the strain of measuring. \* \* \* The original was in constant use by one of my assistants in my office throughout the spring and summer of 1872. When the course of instruction in the Department of Science of the University of Pennsylvania commenced last fall, I accustomed my special geological students to use this instrument among others, and ordered of Heller & Brightly, instrument makers, a duplicate of it, set, however, not to centimeters and millimeters, but to inches and hundredths of an inch. While making it, Mr. Eckley Coxé and other civil and mining engineers saw it, and ordered others like it for their own use, and these orders have become so numerous that it has evidently taken its place among the accepted apparatus of the engineer's office-table. I hope many will in future enjoy the relief and comfort from it which I have enjoyed since 1868.

I was urged to patent it, as Mr. Cleaver patented his Protractor. But I feel a natural prejudice against patenting a little thing which may become to some extent a public benefit, at all events within the not altogether narrow limits of one of the scientific professions. I desire, however, to prevent any one else from hampering its progress by a patent, and to that end beg leave to place this record of its invention among the proceedings of this Society. Any one can obtain the instrument free of patent royalty, from the makers above named, or may order it made for themselves anywhere else.

This Micrometer consists of an arc set with three, four or more needle-points fixed at intervals of one centimeter, one-half inch, or any other unit adopted for the survey, equivalent say to 100 feet (yards, links, rods, etc.).

A handle projects upward from the inside of the arc by which to hold it, and by which it may be applied to the line of course and be gently rotated, so that each needle-point in its turn pricks its (100 feet) unit distance along the line.

Between the last two needle-points floats a supernumerary needle-point or compass-

leg, jointed high up on the handle, and swung or floated to and fro by a simple ratchet and watch chain, turned at will by means of a button, projecting from the centre of a circular disc on the handle; the disc circle being divided into hundredths (thousandths, etc.), and traversed by an index which starts from and comes round to a stop at zero.

While the index travels over the disc from 0 to 100 the supernumerary needle-point travels from needle-point to needle-point, one unit.

Example of use: Suppose a distance 327 feet to be laid off on a course; the fifth needle is applied to the station (point of tangent, or point of curve) and the arc rotated, so that the fourth needle pricks 100, the third 200, the second 300 feet. Then, the index being brought to 27, the floating needle pricks 327.

Mr. Eckley Coxe has had a useful addition made to his instruments in the shape of a set of removable rings, divided for 100ths, 1000ths, 66ths, 33ds, etc., etc. Two little screws hold the ring in place, whichever one may be in request for any particular plotting. When plotting on the scale of some other unit of distance is required, another ring is substituted.

---

[COPY.]

PHILADELPHIA, OCT. 24, 1873.  
530 NORTH SIXTH ST.

WALTER SHANLY, ESQ., *Hoosac Tunnel*.

DEAR SIR:—At Mr. Heller's request I drop you this note, to say that I have examined his improved Telescope, and that it is really a *most important and useful affair*. I could scarcely believe my eyes when I first saw for myself the extraordinary power of his instruments. I add on my own responsibility that I consider the engineering instruments of Messrs. Heller & Brightly superior, by far, to any others that are made.

They need, however, to be seen and used before such a sweeping remark can be fully realized.

In haste,

Yours, very truly,

JOHN C. TRAUTWINE.

## IMPROVED METHOD OF MEASURING IN MINE SURVEYS.

(From the Engineering and Mining Journal, New York, April 25, 1874.)

A paper read at the New York meeting of the American Institute of Mining Engineers, February 27, 1874, by ECKLEY B. COXLE.

In making surveys in the anthracite coal regions of Pennsylvania, the ordinary engineer's chain (50 or 100 ft. long) is generally used, both above and below ground. Sometimes, where it is difficult to chain, as, for instance, across a chasm, a wire is stretched from one station to the other, the distance is marked on the wire and its length is then measured with the ordinary chain. Having had occasion lately to make some surveys where it was necessary to determine with great accuracy the position of the land or property line, not only in the gangways or levels, but also in the breasts or chambers, the coal on the north side of the line belonging to one party and that on the south side to another, and as it is very difficult to measure up the breasts or slopes with accuracy, and to make the proper allowance for the pitch of the vein (the true horizontal distance being, of course, the product of the distance measured with the chain by the cosine of the angle of inclination of the chain), and as the ordinary method of chaining up or down steep slopes on the surface, by holding a portion of the chain horizontal and plumb down from the high end, would in most cases be very difficult and dangerous, and sometimes impracticable, I determined to adopt a new plan which would do away with most of the above difficulties, and by which I could eliminate many causes of error from my ordinary chaining.

My first idea was to have a fine steel wire rope, about 300 ft. long, stretched as much as possible in making, so as to do away as well as I could with that source of error, and then to have it graduated every ten feet. I proposed using small brass tags of different shapes to designate the different hundred feet thus:

- 0—100 a triangle.
- 100—200 a square.
- 200—300 a circle, etc.

The numbers of the ten feet spaces were to be marked by drilling small holes in the tags. I intended to use this for the principal lines of my surveys and to use the chain only for lines which were not of great importance.

When I called upon Mr. HELLER (of HELLER & BRIGHTLY, the instrument makers, of Philadelphia) to order this measure, he suggested that it would be better to use instead of a wire rope, which would stretch, the bands which are manufactured for hoop skirts; they are made of tempered steel, are very light, and will not stretch sensibly. After consultation with him, I decided to have the tape measure constructed which is now before you. It is 500 ft. long and weighs 2 lb. 7½ oz. It is a ribbon of tempered steel, 0.08 inch wide, 0.015 inch thick. At each 10 feet a small piece of brass wire is soldered across the tape, the solder, which is white, extending about one inch on each side of the wire. In the latter, a small notch is filed, which marks the exact point where the ten feet ends. The exact distances from the zero point of the tape are marked upon the solder by countersunk figures. The white solder enables one to find the ten feet notches very easily, and, no matter how dirty the tape may be, by wiping off the solder with the finger, the distances are easily read, as the countersunk figures, being filled with dirt, stand out upon the white ground of the solder. The 0 and 500 feet marks are not at the end of the tape, but near it, and are also denoted by a notch filed in a wire soldered to the tape.

The tape is wound upon a simple wooden reel, ten inches in diameter, which is held in one hand and turned by the other. At first some difficulty is experienced in winding up the tape, but a little practice soon overcomes it. Two brass handles, which can be detached, accompany the tape and are carried upon the reel.

*Description of a survey made with the tape.*—The instruments used were one of HELLER & BRIGHTLY'S new 11 inch transits,\* 2 plummet lamps, the 500 ft. tape and a 5 ft. wooden rod divided into feet and tenths. The latter is used to measure the distance from the nearest ten feet to the station. There were two closed sets of lines or surveys, one set entirely above ground, but through the swamps and brush of the anthracite coal region, and one partly above ground and partly in the mines. The latter began at a point in the swamp, went overground 2400.57 ft. to the mouth of the slope, then down the slope (pitch 37 deg.), 276.99 ft. (horizontal distance), then along the gang-

\* Five inch Magnetic Needle. Telescope, 10½ inches long. Telescope, erecting and magnifying, 30 diameters.

way 4272.01 ft. which formed one-half of an ellipse, then up through a breast (pitc about 34 deg.) 275.44 ft. (horizontal distance) to the bottom of an air shaft, then by two plumb lines to the surface, and then through the swamp 141.83 ft. on the surface to the point of beginning. The length of the periphery of the first closed figure was 6660.19 ft.; that of the second 7366.84 ft. Tables I. and II. show the details and calculations of the two surveys:

TABLE I.

Station.	Angle.		Reduced Angle.	Distances.	Positive Sine.	Negative Sine.	Positive Sum of Sines.	Negative Sum of Sines.	Positive Cosine.	Negative Cosine.	Positive Sum of Cosines.	Negative Sum of Cosines.
	Right.	Left.										
1	0°04'	.....	0°04'	664.97	0.78	.....	0.78	.....	664.75	.....	664.75	.....
2	0°47'	.....	0°51'	711.56	10.56	.....	11.34	.....	711.47	.....	1376.22	.....
3	.....	0°52'	0°01'	408.60	.....	0.12	11.22	.....	408.16	.....	1784.38	.....
4	0°33'	.....	+ 0°32'	567.25	5.28	.....	16.50	.....	567.22	.....	2351.60	.....
5	179°32'	.....	-179°00'	186.05	.....	3.24	13.26	.....	.....	186.02	216.58	.....
B	.....	31°12'	-210°12'	88.42	44.48	.....	67.74	.....	.....	76.72	2089.16	.....
B1	.....	19°39'	-229°51'	389.50	297.72	.....	365.46	.....	.....	251.15	1338.01	.....
B2	.....	9°36'	-239°27'	631.00	643.41	.....	898.87	.....	.....	320.73	1617.28	.....
B3	4°06'	.....	-235°21'	381.25	313.62	.....	1212.49	.....	.....	216.77	1300.61	.....
B4	35°55'	.....	-199°26'	752.50	250.37	.....	1462.86	.....	.....	709.63	690.88	.....
B5	62°39'	.....	-188°06'	157.90	.....	32.56	1430.30	.....	.....	154.51	436.37	.....
5	.....	9°01'	-145°18'	527.20	.....	94.57	275.96	.....	.....	23.90	412.47	.....
4	86°27'	.....	-59°21'	464.85	.....	70.60	1083.74	.....	648.29	.....	1060.76	.....
3	.....	44°17'	-103°38'	210.05	.....	48.01	1035.73	.....	149.64	.....	1210.30	.....
2	.....	5°51'	-109°29'	382.20	.....	54.28	981.45	.....	276.22	.....	1466.52	.....
					1466.22	1465.93						
					Difference + 0.29				2588.67	2588.67		0.00

TABLE II.

B	31°12'	-210°12'	88.42	44.48	.....	67.74	.....	.....	76.42	2089.16	.....	
B1	19°39'	-229°51'	389.50	297.72	.....	365.46	.....	.....	251.15	1338.01	.....	
B2	9°36'	-239°27'	631.00	643.41	.....	898.87	.....	.....	320.73	1617.28	.....	
B3	4°06'	-235°21'	381.25	313.62	.....	1212.49	.....	.....	216.77	1300.61	.....	
B4	35°55'	-199°26'	752.50	250.37	.....	1462.86	.....	.....	709.63	690.88	.....	
B5	73°10'	-168°06'	157.90	.....	32.56	1430.30	.....	.....	154.51	436.37	.....	
O	73°10'	-94°57'	270.99	.....	275.96	1154.34	.....	.....	.....	.....	412.47	.....
1	88°44'	-6°13'	661.98	.....	70.60	1083.74	.....	.....	648.29	.....	1060.76	.....
2	.....	11°35'	157.06	.....	48.01	1035.73	.....	.....	149.64	.....	1210.30	.....
3	6°41'	-11°07'	281.50	.....	54.28	981.45	.....	.....	276.22	.....	1466.52	.....
4	8°21'	-3°46'	86.90	.....	4.19	977.26	.....	.....	86.79	.....	1673.31	.....
5	.....	9°26'	12°12'	192.91	.....	40.77	936.49	.....	188.55	.....	1761.86	.....
6	.....	4°31'	10°43'	203.12	.....	59.86	876.63	.....	198.86	.....	1960.72	.....
7	.....	2°17'	7°26'	231.85	.....	58.79	817.84	.....	228.40	.....	2189.12	.....
8	.....	7°35'	21°59'	476.32	.....	178.30	639.64	.....	441.68	.....	2630.80	.....
9	.....	4°09'	17°52'	103.20	.....	31.05	608.49	.....	96.32	.....	2727.12	.....
10	.....	7°56'	25°48'	235.64	.....	102.16	505.93	.....	212.15	.....	2939.27	.....
11	18°50'	-6°58'	370.85	.....	44.98	460.95	.....	.....	368.11	.....	3307.38	.....
12	.....	51°46'	68°44'	80.40	.....	73.85	387.10	.....	44.84	.....	3362.32	.....
13	.....	44°30'	-103°14'	99.95	.....	97.30	289.80	.....	.....	22.88	3329.34	.....
14	.....	78°51'	-182°05'	316.50	11.51	.....	301.31	.....	316.30	.....	3013.04	.....
15	14°59'	-107°06'	151.98	.....	33.80	267.61	.....	.....	147.56	.....	2865.48	.....
16	13°08'	-163°36'	107.95	.....	47.38	220.13	.....	.....	97.06	.....	2768.48	.....
17	.....	18°30'	-169°28'	123.36	.....	22.55	197.68	.....	.....	121.59	2647.19	.....
18	.....	13°15'	-182°43'	209.60	9.93	.....	207.61	.....	.....	209.37	2437.82	.....
19	.....	4°40'	-187°23'	178.54	23.00	.....	230.61	.....	.....	177.65	2260.17	.....
20	58°10'	-129°13'	21.91	.....	18.98	213.63	.....	.....	13.55	.....	2246.32	.....
F	24°44'	-104°29'	173.71	.....	167.56	45.97	.....	.....	43.44	.....	2202.88	.....
E	34°10'	-70°19'	79.82	.....	73.79	.....	27.82	.....	26.39	.....	2229.27	.....
D	21°59'	-48°20'	9.08	.....	6.78	.....	34.60	.....	6.04	.....	2235.31	.....
C	.....	19°08'	-67°28'	25.95	.....	23.97	.....	.....	9.94	.....	2245.25	.....
A	.....	154°46'	-222°14'	106.80	71.81	.....	13.24	.....	.....	79.05	2166.20	.....
B	48°15'	.....	.....	.....	.....	.....	.....	.....	.....	.....	.....	.....
					1565.85	1565.87			2982.12	2981.60		
					Difference - 0.02				Difference + 0.62			

From these we see that the total errors were in the

	Sine.	Cosine.
First case.....	+0.29	0.00
Second case.....	-0.02	+0.62

This is very accurate work, for this kind of mine surveying. We made three other surveys on the same property with equally good results.

In measuring with the tape it is better to have at least three men, one at each end and one to take off the distances and note them. The hind chainman should be a re-

stable man, as he must hold the zero point of the tape exactly at the nail in the stake, or alongside of the cord to which the plummet lamp is suspended. The front chainman has merely to stretch the tape and to see that it passes exactly over the front station. The third man, who carries the five foot rod, starts from the rear station and notes the distances of the breasts, etc., as he goes along until he arrives at the forward end, where he notes the distance of the station from the last one. In measuring distances of over 500 feet, a temporary station is made at 500 feet exactly in the line to be measured.

*Advantages of the tape.*—First, greater facility in measuring up or down slopes, breasts, etc. Second, greater accuracy in measuring from one station to another, as the tape forms a straight line from one station to another, and as there is no error from the use of pins. Third, the tape does not stretch appreciably.

*Disadvantages.*—First. It is liable to break unless carefully handled. Second. It is necessary to roll it up and unroll it, when the distances between stations vary much.

The tape can be easily mended by any watchmaker when it breaks, and Messrs. HELLER & BRIGHTLY make a small sleeve of brass, tinned inside, in which the ends of the tape, when broken, are slipped and then soldered fast by merely heating the sleeve with a red hot poker. They also have little brass clamps to fasten on the tape to mark any point which is to be used several times.

When the men become accustomed to the tape they wind it up and unwind it very quickly.

There are three sources of error which may be referred to, viz.:

I. The extension of the tape by stretching.

II. The shortening of the tape in consequence of the tape assuming the form of the catenary curve.

III. The contraction or expansion due to the change of temperature.

As stated above, the tape does not stretch appreciably, but this error being in the opposite direction is, to a certain extent, compensated for by the shortening due to the formation of the catenary curve by the tape. I subjoin a table, calculated by my assistant, Mr. EDGAR KUDLICH, showing the shortening of the tape due to the latter cause. The tension in practice is from 30 to 40 pounds.

TABLE III.

Length of Tape Measure.	True distance when tape is subjected to a tension of (or chord of the catenary curve formed by the tape).					
	10 lb.	20 lb.	30 lb.	40 lb.	50 lb.	60 lb.
100 ft.....	99.9894	99.9074	99.9988	99.9993	99.9995	99.9997
200 ft.....	199.9153	199.9791	199.9907	199.9948	199.9967	199.9977
300 ft.....	299.7143	299.9294	299.9687	299.9824	299.9887	299.9922
400 ft.....	399.3268	399.8327	399.9260	399.9588	399.9733	399.9815
500 ft.....	498.6775	499.6732	499.8551	499.9185	499.9479	499.9638

According to the table given by HASWELL for the expansion of steel, a tape measure 500 feet long at 32° Fahr., would become 500.6 feet long at 212°, so that a variation of 60° in temperature would only cause a variation of two-tenths of a foot in a 500 feet tape.

In conclusion, I would advise the use of the tape for all important work, while the chain should be used for filling in details, and where accuracy is not absolutely necessary.

DISCUSSION.

Mr. COYE remarked, in answer to questions, that no correction was applied for temperature, and no allowance for stretching of the wire ribbon. He thought its extension was practically *nil*.

Mr. RAYMOND commented on the fact that, while mining and surveying instruments of all kinds had been improved so much in recent years as regards accuracy and precision, the method of measuring distances—the chain—had remained the same. Nothing could be inherently more objectionable as a standard of measurement than a chain composed of links which are liable to wear by friction.



From the *Railway World*, January 23d, 1875.

### ACCURACY OF AMERICAN CIVIL ENGINEERING.

As the Musconetcong tunnel (just bored through the mountain of that name, on the line of the Lehigh Valley Railroad) is one of the longest this side of the Mississippi, being almost exactly one mile long, the following technical details may be interesting to civil engineers:

The headings of the tunnel met on the 16th December, and on testing the alignments, levels and distance, the following were found to be the errors:

The alignment tested to four-hundredths (0.04) of a foot, or a little less than half an inch.

Levels were run over a mountain 5000 feet long and 450 feet above grade; also into the tunnel at each end about 2500 feet, to point where headings met. These tested to fifteen-thousandths of a foot, or less than one-fifth of an inch. The chaining, carried by steel tape-measurements over the same distance, tested, on the headings coming together, to fifty-two-hundredths of a foot, or six and four-tenths inches.

To the non-professional reader it may be necessary to explain that a hole one mile long was bored through a mountain over 400 feet high, that this hole was bored from the two opposite sides of the mountain at the same time, and that the deviation of the centres of these two holes on meeting in the centre of the mountain being termed the "error of alignment."

As the slightest error of observation or of calculation would be productive of the most disastrous consequences, the highest class of engineering skill and of instruments are absolutely necessary, and the results enumerated above show that in works of this class our civil engineers are not behind their European brethren. The "error of alignment" of the Mt. Cenis Tunnel was three feet—of level, two feet ten inches.

The instruments used were made by the firm of Heller & Brightly, of Philadelphia.

---

[Extract from a paper on "The Musconetcong Tunnel," read by Henry S. Drinker, E. M., before the American Institute of Mining Engineers at New Haven, Conn., February 25, 1875, published in full in *The Engineering and Mining Journal* (New York), for May 29, 1875.]

### THE MUSCONETCONG TUNNEL.

This concludes the description of the direct methods of mining employed at Musconetcong tunnel, and it may now be interesting to you, before leaving the subject, to have a summary also of the surveying work done, and of the tests made in meeting in alignment and levels, but first we would say that at date of publication of this paper, the arching has been carried over underneath the shaft, and the latter has been filled with clay and earth to the surface. It is also the intention to turn a five-foot ring for a permanent ventilation chimney up through the slope. This ring will be five feet in diameter in the clear, built four bricks thick, and bearing at the bottom on a retaining wall put in across the slope just where the rock begins, and around this ring the slope will be filled up to the surface.

The transit used was literally a "Heller," it, and all the instruments on the work, being made by the well-known firm of Messrs. HELLER & BRIGHTLY, of Philadelphia. The "Gentleman from Drifton" has already had occasion in several interesting papers to call the attention of the Institute to their mining transit and plummet lamp, and the experience at Musconetcong most thoroughly endorses the favorable opinion he expressed as to their make. The above transit was of the compound centre class; diameter of graduation of horizontal limb, seven inches; telescope, 17 inches long, achromatic and erecting; magnifying power, 28 diameters. A very sensitive bubble is attached to the axis of the telescope, at right angles to the line of sight, and by its careful adjustment and observation, great accuracy may be obtained.

The approach to the tunnel on the west begins on a 5° curve, the P. T. of which is about 800 feet from the entrance, and the tunnel itself located on a tangent throughout its length, the said tangent terminating in a curve, having its P. C. some 1850 feet beyond the east portal. The grade ran to a summit in the middle of the tunnel, the same being the summit for the road. It was reached by a rise of two-tenths (0.2) to

the hundred feet on the west side, or 10.56 feet to the mile, falling on the east at fifteen-hundredths (0.15) to the hundred feet, or 7.92 feet to the mile.

To determine the line after its preliminary location, an observatory was erected on the summit of the mountain, about 12 feet high, with an eight-foot square base, battering on the four sides about  $1\frac{1}{2}$  inches to the foot. Two solid stone foundations were also built on line, one on a hill about half a mile from the west entrance, the other on the grading, at the east end, and about half a mile from the eastern portal. As the observatory was located about midway over the tunnel, this gave, approximately, equidistant sights of about, say, a mile and a quarter each, at the farthest. This, however, was done after the tunnel had been started from points established on both sides by repeated and carefully checked runnings. The tower being subsequently built, two points were established, one each on the foundations, on either side, from the lines by which the work at either end had been so far run, and then assuming these end points as correct, by a series of repeated and careful trials, the centre point on the tower, or permanent back-sight for both ends was determined by setting up, approximately, over it, and then reversing and sighting repeatedly, moving the instrument to and fro sideways, within a variable distance of about fifteen-hundredths (0.15) of a foot, in which the sights all came, and finally taking their mean. This was at first done, as soon as the observatory could be located and built, with sufficient accuracy to test the preliminary lines. Subsequently this centre point was tested, and retested, and determined with extreme accuracy, by the mean of very many trials made both by sighting by day and by night, and in winter and summer. Different objects were used for sighting on in day-work. Both the ordinary red and white round pole, also a flat  $2 \times 1$  inch black pole, with a white centre streak. This latter, from its shape, was found difficult to keep plumb, either when held or fastened. Also a pole of one-half inch round iron, painted white, was tried, and found to answer well, better than either of the others. But far better and more accurate than any daylight back-sight, whether permanent or movable, was found the simple expedient of using plummet-lamps on clear calm nights. They worked admirably outside, a flame  $\frac{3}{4}$ -inch high, by  $\frac{3}{4}$ -inch in diameter, being distinctly seen in the long sights; and with a fine hair, the sights were found, finally, to repeatedly test within practically such exact limits (two or three hundredths), that, the point being once fixed, it was not subsequently found advisable to move it. Now, these three reference points being located, at the west end a centre was set at the mouth of the slope, and from it another at the bottom. This gave a back-sight of 276 feet to run from into the heading. At each shaft a centre was first set, with great care, about twenty-five feet off, and from this the line prolonged to two staples driven into the timbers on each side. On the mean of many sights being determined, the points on both staples were notched, the notches tested, and fine plummet lines dropped from them, the weights being steadied at the bottom, in water. Then the line was continued from these, as in ordinary mine surveying, in running from a shaft, the instrument being first approximately set up in line, and then moved sideways, until the hair exactly bisected the mean of the slight oscillations observable in the lines. Though the distance to be run from the shafts was not great, this care was necessary from the shortness of the back-sight, the distance between staples being only some  $7\frac{1}{2}$  feet, and from the fact that the headings were through earth, it being very necessary in enlarging through earth to be able to have the crown bars closely located at equidistant spaces from centre. On the headings between the shafts and slope meeting, the various runnings all tested closely; but it was the long line between the main east and west headings that required, of course, the most care, and caused the most anxiety. This line, at the east end, was simply continued on the grading, up into the heading, at first with one, and, subsequently, as the headings advanced, with two intermediate centres. At the west end, the line was at first run into the main heading (No. 1) down the slope, but as the enlargement in soft ground proceeded between the slope and west end, in time a clear sight was obtained from the mouth of the tunnel to the slope, and thence into the heading, making two intermediate centres, as at the east end. It was always necessary to have a station where the slope came down, since the latter was driven, after meeting rock, sixteen feet wide—thirteen on the left and three on the right of centre line, leaving at its foot about ten feet of space for passage on the right, as the line ran, and, of course, cutting off centre line. The three feet on the right, however, were dressed off, subsequently, at the level of the heading, so as to give a clear back-sight to the mouth.

These east and west lines were repeatedly run and tested as the headings advanced, and, besides the work continually spent on them by the Division and Resident Engi-

neers, they were frequently checked by the Principal Assistant Engineer. They finally tested within four hundredths (0.04) of a foot, or less than one-half an inch. The levels were carried over the mountain by a series of test benches run until succeeding benches tested within five thousandths (0.005) of a foot. On meeting, the face benches on either side were found to test within fifteen thousandths (0.015) of a foot, or less than one-fifth of an inch. Owing to the system of centre cuts, used in blowing the rock, in which ten feet at a time were brought out, it was especially necessary that the chaining should be accurate, so that the distance apart of headings might be safely determined. To measure over the mountain, two stout frames were made, steadied by weights on the legs. They each simply consisted of a vertical shaft with three legs, one movable. From a board nailed on the top of the shaft a fine plummet was hung. The two were put in line, the plummets centred by the transit, and a point at the top of one line leveled with a point near the bottom of the other, and the measurement thereon taken between the two with steel tape. The hind frame was then moved on, and the chaining so carried up or down hill in successive steps. This method was found to be satisfactory; for, on the headings coming together, the distance apart, predicted and marked, was found to agree with the measured distance within fifty-two hundredths (0.52) of a foot, or about six inches out in a total chaining of about eight thousand feet, four thousand through headings, and four thousand over the mountain, the test measurement being brought down the slope on angle instead of in at the west entrance.

#### **"INSTRUMENTS OF PRECISION" FOR EDUCATIONAL INSTITUTIONS.**

It will interest our readers to know that a number of the leading Educational Institutions that make Civil Engineering and the use of field instruments a part of their course of study are at the present time procuring full sets of the most modern styles of instruments. We have recently been shown by Messrs. Heller & Brightly full sets of their field instruments that they have just finished for Dartmouth College, New Hampshire, the University of California, and for Princeton College, New Jersey. These instruments are all very complete in their details, no expense nor pains seeming to have been spared. The instruments for Princeton are duplicates of the instruments lately furnished by this firm for the University of Pennsylvania and for the Imperial College of Japan, the Plane Table being especially a very complete instrument. The Telescope of the Engineer's Transit for Dartmouth College is provided with an "eyepiece micrometer," of a new design, that appeared to us to possess special merit; this Transit, instead of the four leveling screws, as is usual in American instruments, has a new "three leveling screw tripod," devised by Professor Quimby of the college, that possesses some points that render it superior to its European prototype, especially in having a shifting head, the allowing of the leveling screws to be packed away in the box, and being less cumbersome.—*Educational News, January 6th, 1876.*

## INFORMATION TO PURCHASERS.

---

As we have only **one grade of goods**, and **one price**, and never deviate from either, it is **not absolutely necessary** for parties to apply to us in person, for the purpose of purchasing or selecting any of our instruments.

The modern system of **Express Agencies** is now so complete as to have their agents at every important point in the United States and British America, and these agents in their turn forwarding by stage, etc., to places where there is no Express agency. This Express system renders it safer and more expeditious at the present day to send goods one thousand miles than to have sent them thirty miles away twenty years since.

As to the **good condition and safety** of the instruments that may be transported by express;—We **pack** in such a manner, and make such provision for their safe transportation, that we guarantee the good condition of the instruments on their arrival at their place of destination, after being forwarded by express; and hold the express company liable to us for all loss or damage that may be incurred on the way.

It is perhaps unnecessary to say that we **warrant** the instruments, in all their parts, to be made of good material and of good workmanship, and with no original defects.

**In ordering instruments**, all that is necessary, is to write or telegraph to us the kind of instrument desired, and we will forward by Express, (unless a different method be desired). In giving the address to where the articles are to be forwarded, be careful to **give the County as well as the State**, thus: Send "Combined Transit and Levelling Instrument," price —, and the following extras, —, —, by express, to **Wm. Andrews, Civil Engineer,**

Linden,

Cass County,  
Texas,

as in some States there are several Express stations of the same name.

As there are three Chicagos, three Cincinnati's, six Philadelphia's, etc., in the United States, and each of them in a different State, it is best to **always do this**, even if the articles are to be sent to a **large city**.

Terms of payment are uniformly cash, and any of the following methods can be adopted: remitting to us a draft on any banker or broker, in this or any eastern city; or a "post-office money-order." **The best method** is however by the **Express C. O. D.** system (collect on delivery). That is, the party ordering, paying the amount of our bill to the Express Agent on receipt of the goods.

Although we have our own standard and approved patterns, if **any change** in the style of the instrument, graduations, or numbering of the degrees be **desired**, we can do it.

---

## HOW TO SEND INSTRUMENTS FOR REPAIRS.

**In sending instruments** of our own, or any other makes, to us for repairs, it is **only necessary** to place them in their own boxes, fill the box with some elastic material, such as paper, rags, etc. Place this in a packing-box at least an inch larger in its dimensions than the instrument box, and fill the space between the two with shavings, straw, hay, etc. Mark on the box simply **Heller & Brightly, Mathematical Instrument Makers, Philadelphia, Penna.** Send it to us by **express**, and get at the same time from the agent two receipts; keep one, and **forward the duplicate** to us. Send by mail at the same time, a letter to us giving the items as to what repairs are needed and the time when the instrument is **again required**; and place a duplicate of this letter in the box with the instru-

## INFORMATION TO PURCHASERS.

ment. If the Express charges to Philadelphia are prepaid by the sender (which is optional), it will be so stated in the receipt before mentioned.

Our charge for repairs can be paid by the Express Agent (C. O. D.), on our returning the articles. Remember, however, **always to send the spindle** (or ball and socket, if it be a Surveyor's Compass) on which the instrument turns, as it cannot be adjusted without; and a socket must be improvised at additional cost to the owner, if it be not sent. If, when the instrument is not of our make, it is required to be **tested for magnetic attraction, or defective graduation**, the fact must be mentioned in the letter of advice to us.

If the distance be not too great, it would also be **best to send us the tripod legs and head**, as the legs are frequently loose in their cheeks, and the iron shoes at their ends shaky and points worn off.

When instruments are sent to us to be repaired, we will, if requested, **test any steel tape or chain** that may be forwarded with them without extra charge, and give their difference in length as compared with the true United States standard (see "straight line measurements"), and the state of the thermometer at the time of trial. If, however, any repairing or adjusting of the chains, etc., be required, there will be an extra charge.

We have been frequently asked, since we have increased the power of our Telescopes, whether we could not **place our new Telescope on instruments made by other firms**. We have heretofore uniformly refused, as our new Telescope is a distinguishing feature of our instruments as compared with others. We have however reconsidered our determination, and will alter any Telescope to our new one; **but in cases of this sort** we will engrave on the Telescope tube the name of our firm. In altering the Telescope, all that will be necessary in a majority of the cases, will be to **remove the old object glass and eye piece**, insert new ones, and to **change the place of the cross wires**.

---

## WHAT IT COSTS TO SEND A TRANSIT OR LEVELING INSTRUMENT FROM PHILADELPHIA TO ANY PART OF THE UNITED STATES OR CANADAS, OR VICE VERSA.

Parties from a distance frequently write us, "I have an instrument that requires repairing; about how much will be the express charges to Philadelphia from this place?" In order to give such parties an approximate idea of the cost of transportation, we give the following table of charges upon fifty and twenty-five pounds of freight to Philadelphia from one or more cities in each State. An engineer's transit, such as is made by regular makers (our own is somewhat lighter), with tripod head and legs, packed for shipment in two strong packing-boxes, these boxes filled in with some elastic material, such as paper, shavings, etc., will average fifty pounds; the tripod head and legs alone, also packed in strong box, etc., will average from twenty to twenty five-pounds; tripod head, with leveling screws, etc. (but without the wooden legs), will average six pounds. (See Table of Express Freight Charges.)

From the table given it will be seen that the cost of sending a transit in its box from any part of the United States or Canadas is so moderate (being only in the neighborhood of \$2.50 from Kansas to New York or Philadelphia) that it is the best policy, if a valuable instrument receives any injury anywhere in the United States, to send it to those who have all the facilities for making the necessary repairs and adjustments. As to any extra delay incurred, we will state that seven days only are needed to bring a transit from San Francisco to Philadelphia, and that the most seriously injured instrument, as a general rule, can have all the necessary repairs and adjustments made in six days. As an offset to this, there is the surety of the repairing being properly done, and in many instances the low prices charged by parties having the facilities for quick work more than counterbalance the express charges.

**INFORMATION TO PURCHASERS.**

**THE CHEAPEST AND MOST EXPEDITIOUS MODE OF SENDING  
SMALL PARCELS TO ANY PLACE IN THE UNITED STATES  
OR CANADAS.**

Surveyors are now very generally taking advantage of the post-office law allowing parcels of merchandise, if not weighing over four pounds nor measuring over three feet, to be sent through the mails at one-sixth the cost of letter postage (the postage on merchandise being one cent an ounce, while letters cost six cents an ounce); and almost all small articles, such as tripod heads, leveling screws, clamp screws, compass glasses, level tubes requiring new glasses inserted, hand levels, pocket compasses, etc., are sent or returned in this manner, as it is cheaper and more expeditious than to forward by express. From the above it will be seen that the cheapest and most expeditious way to send small articles is through the mails, as packages not weighing over four pounds nor measuring over three feet can be sent to us from any part of the United States in this manner at a cost of one cent an ounce, postage to be prepaid by stamps. Or, in other words, a six-pound tripod can be sent to us from San Francisco at a cost of ninety-six cents by mail, whereas by express the expense would be more than double. Similar packages can also be sent by mail from any place in Canada to any part of the United States at a cost of ten cents for every eight ounces. Recollect, however, that the post-office limits single packages to four pounds in weight. The six-pound tripod mentioned above would therefore have to be separated into two parcels. If circumstances, however, require it, an entire instrument may be sent by mail, if the precaution be taken to separate it in such a manner that none of the packages exceed the regulation four pounds. Tie the parcels in strong paper and merely address them (by tag or otherwise), "HELLER & BRIGHTLY, MATHEMATICAL INSTRUMENT-MAKERS, PHILADELPHIA, PA.

Another way in which the articles may be sent is to pack them securely in a pasteboard box, or else a skeleton box of four strips of wood, similar to those in which pianos or sewing-machines are packed. Recollect also to so wrap or envelop what you wish to send (if packed in a pasteboard box, with openings cut) that the articles may be seen without destroying the wrappers. No writing or mark of any description whatever (excepting the address) must be placed anywhere on the parcel, as this will subject the entire package to full letter rates of postage, three cents a half ounce. It is also best to write the address upon a tag, and tie this tag in such a manner to the parcel that it cannot possibly get loose.

If the surveyor is in doubt as to whether his package is properly packed, the precise amount of postage stamps to be placed on it, etc., etc., he may obtain full information by inquiring at his own post-office before sending.

**TABLE OF EXPRESS FREIGHT CHARGES FROM PHILADELPHIA TO ALL PARTS OF  
THE UNITED STATES AND CANADA, OR VICE VERSA.**

STATES.	CITIES.	Freight		STATES.	CITIES.	Freight	
		on 25 lbs.	on 50 lbs.			on 25 lbs.	on 50 lbs.
Alabama.....	Montgomery....	\$1.88	\$3.14	New Jersey.....	Trenton.....	\$.14	\$.24
Arkansas.....	Little Rock.....	2.60	4.35	New Mexico.....	Santa Fé.....	7.82	13.04
California.....	San Francisco...	7.28	12.14	New York.....	New York.....	.18	.30
Colorado Ter'y.....	Denver.....	4.22	7.04	"	Albany.....	.62	1.04
Connecticut.....	Hartford.....	.54	.90	"	Troy.....	.62	1.04
Dakota.....	Yankton.....	2.88	4.80	North Carolina..	Wilmington....	1.10	1.94
Delaware.....	Wilmington....	.14	.24	Ohio.....	Cincinnati....	1.16	1.94
Dist. of Columbia.	Washington....	.45	.76	"	Cleveland.....	.98	1.64
Florida.....	Tallahassee....	2.78	4.64	Oregon.....	Portland.....	8.36	13.94
Georgia.....	Savannah.....	2.06	3.44	Pennsylvania....	Harrisburg....	.21	.36
Idaho Territory...	Boise City.....	11.24	18.74	"	Pittsburg.....	.62	1.04
Illinois.....	Chicago.....	1.34	2.24	"	Lancaster.....	.18	.30
"	Peoria.....	1.62	2.70	"	Reading.....	.18	.30
Indiana.....	Indianapolis....	1.44	2.40	"	Wilkesbarre....	.36	.60
Iowa.....	Dubuque.....	1.70	2.84	Rhode Island....	Providence....	.54	.90
Kansas.....	Leavenworth....	2.42	4.04	South Carolina..	Charleston....	1.52	2.54
Kentucky.....	Louisville.....	1.34	2.24	Tennessee.....	Memphis.....	2.06	3.44
"	Covington.....	1.30	2.18	"	Nashville.....	1.88	3.14
Louisiana.....	New Orleans....	2.16	3.60	Texas.....	Galveston....	2.60	4.35
Maine.....	Bangor.....	.98	1.64	"	San Antonio....	7.34	4.40
"	Portland.....	.90	1.50	Utah Territory...	Salt Lake.....	5.12	8.54
Maryland.....	Baltimore.....	.26	.44	Vermont.....	Burlington....	.76	1.28
Massachusetts....	Boston.....	.44	.74	"	Montpelier....	1.26	2.10
Michigan.....	Detroit.....	1.26	2.10	Virginia.....	Richmond.....	.72	1.20
Minnesota.....	St. Paul.....	2.42	4.04	"	Norfolk.....	.54	.90
Missouri.....	St. Louis.....	1.70	2.84	Washington Ter'y	Olympia.....	9.08	15.14
Montana Ter'y....	Helena.....	15.58	25.99	West Virgiula...	Wheeling.....	.72	1.20
Nebraska.....	Omaha City....	2.24	3.74	Wisconsin.....	Milwaukee....	1.34	2.24
Nevada.....	Virginia City...	7.52	12.54	"	Racine.....	1.34	2.24
New Hampshire...	Concord.....	.86	1.44	Wyoming.....	Cheyenne.....	3.68	6.14

(ESTABLISHED 1870.)

**HELLER & BRIGHTLY,**

**MATHEMATICAL, OPTICAL, ENGINEERING, SURVEYING AND ASTRONOMICAL INSTRUMENT MAKERS,**

**S. E. Cor. Spring Garden & Ridge Ave., Philadelphia.**

**PRICE LIST.**

PHILADELPHIA, July 1, 1889.

**NOTICE.**—As we have in the present edition made alterations in the prices of our Engineering Instruments, etc., the present Price List will supersede all others.

**TRANSIT.**

**Complete "combined Transit and Leveling Instrument,"** for Civil Engineers and Surveyors (similar to illustration)—**5 inch magnetic needle.** "Long compound centres" to plates—all graduations on silver plate. The degrees of the ring and horizontal plate numbered in two rows, one row in quadrants ( $0^{\circ}$  to  $90^{\circ}$  each way), and the other row a continuous one (for repeating an angle) from  $0^{\circ}$  to  $360^{\circ}$ .—**Double opposite verniers** to horizontal limb.—All the level bubbles ground.—Long sensitive level bubble, vertical arc, clamps and tangent screw movement to axis of Telescope.—Tangent screw motions, both to the horizontal limb and vernier plate. Clamps on Telescope axis, arranged with sighting slits and index marks, for right angle sighting (for offsets). Telescope achromatic and erecting, of extra high power and range, (magnifies 28 diameters; and will read time on an ordinary watch dial at 983 feet distance). Telescope balanced in its axis, reversing both at eye and object ends, and with one end of its axis adjustable.—Slide for closing aperture in cap, when not in use. Shifting tripod head to tripod, for precisely centring the instrument over a point, after approximately setting by the tripod legs. Extra wide openings in vernier plate for reading the horizontal limb.—Tripod head, with the levelling screws, etc., detachable both from the instrument proper, and from the tripod legs, for packing away in the box.—Length of Telescope  $10\frac{1}{2}$  inches; Diameter of object glass  $1\frac{1}{4}$  inches..... **\$220.00**

The instrument is securely packed in mahogany box, with leather strap, hooks, lock and key.—India-rubber washers to the bottom of the box to prevent disarrangement of the adjustments by transportation.—Packed in each box, and included in the price, are a magnifier for the easy reading of the graduations, plummet, sun-shade for Telescope, adjusting-levers, and two screw-drivers.

**Plain Transit**—similar to the above in every respect, excepting that it has no level, vertical arc, clamps nor tangent screw motion to the axis of Telescope..... **\$185.00**

**EXTRAS TO PLAIN TRANSIT.**

By attaching the first three following extras (weight about 16 ounces) to a plain Transit, it is changed into a "complete, combined Transit and Leveling Instrument.

- Vertical circle  $5\frac{1}{2}$  inches diameter (reading to minutes of arc)..... **\$25.00**
- Or vertical arc, 7 inches radius, and vernier clamp..... **15.00**
- Clamp and tangent movement to axis of Telescope..... **15.00**
- Long level on Telescope, ground bubble and scale ..... **15.00**
- "Slit sights" on Telescope, to fold down on the Telescope when not in use. **12.00**

**EXTRAS TO EITHER PLAIN OR COMPLETE TRANSIT OR LEVELING INSTRUMENT.**

(Any or all of which may be added at will.)

- Rack and pinion movement to eye piece (for focussing cross-wires)..... **5.00**
- Adjustable Stadia hairs (with accurate and firm adjustment to the slides, and so arranged that the Micrometer or Stadia hairs can be adjusted without disturbing in the least the adjustments of the ordinary horizontal and vertical hair). Unless otherwise ordered, we adjust them so as to

PRICE LIST.

precisely take in 1 foot of a rod, placed at 100 feet distance from the instrument.....	\$10.00
extra detachable top Telescope, for vertical sighting in shafts. For description of this Telescope, and manner of its use, see page 7.....	35.00

(This Telescope is only furnished at this price when ordered with the instrument.)

OFFICE OF HELLER & BRIGHTLY. }

TRIAL OF INSTRUMENTS BEFORE ACTUAL PURCHASE.

We judge from numerous letters received by us, and the knowledge that we have increased the power of the ordinary Telescope, has been made public, that a personal examination of the Telescope and instrument before making a final purchase, would be desirable to parties who are but slightly acquainted with us and our reputation. We make to such the following proposition: On making known to us the kind of instrument they desire, we will forward it to their address by express; and we will direct the express agent on delivery of the instrument to collect the amount of our bill, but instead of forwarding to us immediately as is usual, he will hold the money on deposit for say four days, or until the purchaser shall have thoroughly tested the instrument in the field. The purchaser can take the instrument and give it an actual trial in the field four days should be ample for this, and if not found as represented, strictly first-class in all parts, and perfectly satisfactory in every respect, he may return it to the express agent before the expiration of the four days, and receive the money paid in full and no sale. The express agent will then return the instrument to us at our expense. If, however, the instrument is not returned to the express agent within the four days, it will be presumed that it is perfectly satisfactory, and the agent will forward the money to us.

In sales of this sort, however, as in all our other sales, our original warranty holds good—i. e., that any time after purchase if any defect appears after reasonable use, we agree either to replace with a perfect instrument or to refund the purchase money.

MARCH 25, 1874.

Report of, to lower .....	
Or one extension leg, to suit regular Tripod.....	5.00
Plated reflector for graduations (see page 7).....	4.00
“ “ “ cross hairs “ “ “.....	4.00
Small adjustable Table for lamp “ “ “.....	15.00
Lamp for Mining Engineer of new design, can be used either attached to the hat, in the hand, or on table, made of heavy sheet copper; seams lapped, and the copper tested as to its freedom from magnetic attraction; weight about 5 ounces (for full description see page 7).....	2.00



(ESTABLISHED 1870.)

**HELLER & BRIGHTLY,**

**MATHEMATICAL, OPTICAL, ENGINEERING, SURVEYING AND ASTRONOMICAL INSTRUMENT MAKERS,**

**S. E. Cor. Spring Garden & Ridge Ave., Philadelphia.**

**PRICE LIST.**



**EXTRAS TO EITHER PLAIN OR COMPLETE TRANSIT OR LEVELING INSTRUMENT.**

(Any or all of which may be added at will.)

**Rack and pinion movement to eye piece** (for focussing cross-wires) ..... 5.00  
**Adjustable Stadia hairs** (with accurate and firm adjustment to the slides, and so arranged that the Micrometer or Stadia hairs can be adjusted without disturbing in the least the adjustments of the ordinary horizontal and vertical hair). Unless otherwise ordered, we adjust them so as to

**PRICE LIST.**

precisely take in 1 foot of a rod, placed at 100 feet distance from the instrument.....	\$10.00
<b>Extra detachable top Telescope</b> , for vertical sighting in shafts. For description of this Telescope, and manner of its use, see page 7.....	35.00
(This Telescope is only furnished at this price when ordered with the instrument.)	
<b>Plated reflector</b> for graduations (see page 7).....	4.00
“ “ “ cross wires (see Professor Raymond's paper).....	4.00
<b>Extra tripod head</b> with three extension legs (see "Franklin Institute Report"), to lower or raise the instrument in contracted workings.....	\$20.00
Or one extension leg, to suit regular Tripod.....	5.00
<b>Small adjustable Table</b> to attach to tripod for holding lamp, weighing 16 oz., and packing away in box (for description and use see page 7).....	10 00
Extra magnetic needles, centre pins, levels, compass dial glasses, magnifiers, adjusting levers, plummets, plummet cord, camel's hair brush and buckskin for glasses of Telescope. (See further priced extras after "Surveying Compasses.")	

**SMALL MINING AND RECONNOISSANCE TRANSIT.**

A full detailed description of this new instrument, which we have lately designed and introduced, will be found in the paper of Professor R. W. Raymond read before the Association of Mining Engineers (which see).

<b>Small Mining and Reconnaissance Transit</b> , with level, vertical arc, etc. (similar in every respect excepting size and weight to our complete combined Transit and Level—which see).....	\$198.00
--	----------

Our attention has been called to imitations of our Mining Transits that have been placed on the market since we first introduced our style; and as from the tenor of the communications and inquiries we have received persons may be deceived by the close imitation, we give some of the leading points in which they differ. As far as the size is concerned, they are close copies, Professor Raymond's paper giving all the various dimensions, and rendering imitation in this direction easy. They can, however, be detected in the following points.—The metal of which they are made is the ordinary hammered yellow brass;—the windows for reading the verniers of the horizontal limb are only half the length; (our window openings being full two inches long). Our verniers are opposite, have double readings, and read to single minutes of arc; the imitation has single readings, and in some cases only read to three minutes (3'). Our graduations are upon silver plate; the imitation on the brass and silver washed. Our centres are the "long compound;" the imitation has the "flat Surveyor's style." Our plates, etc., are "ribbed" and "braced;" the imitation ones are solid, and of course the instrument heavier. The Telescope is, however, the part where the greatest difference exists, ours being erecting, 7¼ inches long, and of a high magnifying power (over 17 diameters), the imitation having the ordinary inverting eye piece (Ramsden's), and being longer.

**EXTRAS TO SMALL MINING TRANSIT.**

(Any or all of which may be dispensed with at will.)

<b>Extra top Telescope</b> , detachable at will, for vertical sighting (see page 7 for description of this Telescope and manner of its use).....	\$35.00
(This Telescope is only furnished at this price when ordered with the instrument.)	
<b>Adjustable Stadia</b> or "Micrometer" hairs (see regular, complete, etc., Transit).....	10.00
<b>Extra tripod head</b> with three extension legs (see "Franklin Institute Report"), to lower or raise the instrument in contracted workings.....	20.00
Or one extension leg, to suit regular Tripod.....	5.00
<b>Plated reflector</b> for graduations (see page 7).....	4.00
“ “ “ cross hairs “ “ “.....	4.00
<b>Small adjustable Table for lamp</b> “ “ “.....	15.00
<b>Lamp</b> for Mining Engineer of new design, can be used either attached to the hat, in the hand, or on table, made of heavy sheet copper; seams lapped, and the copper tested as to its freedom from magnetic attraction; weight about 5 ounces (for full description see page 7).....	2.00

PRICE LIST.

TUNNEL TRANSIT.

**Tunnel Transit**, with Telescope 17 inches in length—long compound centres, 5 inch magnetic needle, double opposite verniers to horizontal limb. (See page 8, Franklin Institute Report, and letter of Mr. Steele for further details)..... \$238.00

SOLAR TRANSIT.

**Solar Transit**.—This is our regular "Complete combined Transit and Level Instrument," with the addition of the Saegmuller Patent Solar Attachment (the solar attachment is detachable and can be placed away in the transit box when not in use),..... 300.00

PLANE TABLE.

**Plane Table** of the most approved modern construction, with **Alidade**—detached **Compass box**, level, scale, etc.,—**Table** 24 inches square—alidade with *movable edge* (this is a most important and time-saving improvement, as double the amount of field work can be done in the same time as with the ordinary style of instruments, and with greater accuracy). Telescope extra powerful with vertical arc, and with adjustable Stadia hairs—Tripod very firm and with shifting head.—The whole instrument braced in a manner to best resist side torsion ..... 295.00

(Long Level under Telescope, \$10 extra.)

**Telemeter Rod** (hinged and graduated) to use with Plane Table..... 25.00

All the above instruments (as well as those that follow) are reduced to about half the weight of instruments made in the ordinary way.—This being effected by "ribbing" and "bracing," all the parts.

The mode is fully explained in "the Report of the Committee of Civil Engineers appointed by the Franklin Institute of Philadelphia to examine Heller & Brightly's improved Transit," and in the paper read before the "American Philosophical Society."

LEVELING INSTRUMENT.

**Engineer's Leveling Instrument**, with "long centre" (instrument similar to illustration), Telescope, bar and centres arranged in such a manner as to detach above the leveling screws, without the possibility of jarring the instrument or its adjustments.—Tripod head and leveling screws detachable from the tripod legs, for packing away in box.—Telescope 17 inches long, erecting, achromatic and extra powerful.—Index lines on Telescope and Y's for setting vertical hair truly vertical, packed in mahogany box with sunshade, adjusting pins, etc.,..... \$145.00

SMALL MINING AND RECONNOISSANCE LEVEL.

This **Mining and Reconnoissance Level** is a companion instrument to the Mining and Reconnoissance Transit, and is a fac-simile of our regular Engineer's Leveling Instrument (which see) in every respect excepting size and weight—length of Telescope 10½ inches—aperture of object glass 1 inch—magnifying power 28, diameters, shows objects erect, and will read face of a levelling rod *direct* (i. e., without the aid of a target) at 700 feet. This Leveling Instrument fits the tripod head of the Mining Transit, and one tripod, if need be, will answer for both.—The whole instrument weighs without tripod 2½ pounds, and is packed in a mahogany box, 12 inches long, 4 in. wide, and 6 inches deep; a strap is furnished to carry box over the shoulder in the manner of army officer's field-glass.

Price without tripod (where Transit tripod interchanges with Level)..... \$105.00  
Tripod head and legs..... 10.00

**Plummet lamps** with "compensating ring" (for description and manner of use see Prof. Raymond & Eckley B. Coxe's papers before the American Association of Mining Engineers), singly..... 13.00  
Per pair ..... 25.00

Neat light box, with lid and shoulder strap, to carry a pair of these lamps, is also furnished if desired.—Price of box with strap..... 3.00

**PRICE LIST.**

<b>Plumb-bob</b> of brass, with steel point, accurate (see test for plumb-bob)....	\$2.50
<b>Clinometer</b> or Slope Level, straight bar.....	12.00

**HELLER & BRIGHTLY'S STEEL TAPE MEASURE  
(STANDARD).**

These Tapes can be graduated by us in any manner that may be desired. For Bridge building, or City work, we generally make them 300 feet long. The first 290 feet graduated and numbered at every 10 feet distance; the next 9 feet at every foot, and the last foot into 10ths, or even closer if preferred. For Mine or Railroad work, they are generally desired either 400 (a 400ft. Tape weighs without handles 2½ lbs.) or 500 feet in length, and graduated in a similar way to the above. We also furnish, if wanted, a "Clamping Handle," that can be attached to any portion of its length, in order that any measure shorter than the whole length can be taken without unwinding the entire length from the reel. (See account of a new measuring apparatus for straight lines.)

<b>Steel Tape</b> (of any length that may be desired, from 100 to 1000 feet), with no joint from end to end. Lengths and graduations of precise U. S. standard (guaranteed).	
First 100 feet.....	\$6.00
Every extra 100 feet .....	5.50

At the above price every 50 ft. is marked and figured, but no reel nor handles are furnished.

**EXTRAS.**

Every extra graduation and figuring, each.....	\$ .20
Large brass handles to unship, each.....	1.50
Reel, with handle and stop, (to wind up Tape).....	3.50
Spring Balance, to use with above.....	.50
Clamping Handle.....	1.80
Small Sleeve of brass. This sleeve is tinned inside, in which the ends of the tape when broken are slipped, and then soldered fast by merely heating the ends of the sleeve with a hot poker.....	.10
Small brass clamp (to fasten on tape to mark any point which is to be used several times).....	.75

The cost of a 100 foot Tape, graduated and figured up to 90 feet at every 10 feet, the next 9 feet at every foot, and the last foot into 10ths, would be (without reel or balance):

Tape (graduated at every 50 feet).....	\$6.00
24 extra graduations and figuring the same, at 20 cents each.....	4.80
Pair of brass handles (to unship).....	3.00
	<hr/> 13.80

**LEVELING RODS.**

<b>Self-reading</b> (but with target) Philadelphia Leveling Rod.....	\$18.00
New York Leveling Rod and Target.....	16.00
Ranging poles for Transit, 8 feet long.....	2.25
10 " ".....	2.50

**Barometer for Leveling, Surveying or Reconnoissances**, dial graduated to read from 8000 to 10,000 feet altitude—these barometers are carefully tested by us with a standard Barometer in the following manner. We place them under the receiver of an air Pump, and as the air is exhausted (equivalent to ascending a mountain) the two dials must note the same height .....from 25.00 to 35.00

<b>Metal "Aligning" or Ranging Poles</b> .....	6.25
--	------

These poles were designed by us for very accurate sighting in Tunnel Engineering, and gave such good satisfaction, that we have introduced them for close city and other work. They consist of a heavy bronze tube 11-16ths of an inch outer diameter and about 7 feet long, divided off into feet, which are painted white and red alternately, with brass shoe and steel point on one end, and on the opposite end a drill for transferring centres into stone, etc.; and as the steel points and the tube are turned in a lathe at the same time, absolute coincidence between the rod and the points is had. The weight is about that of an eight-foot wooden pole; they will stand a heavy blow without bending, and the cost is but little more than for the inferior wooden ones.

**PRICE LIST.**

**SURVEYING COMPASSES.**

As we make and test our Compasses in a more accurate manner than is usual, we are compelled to charge a higher price than is asked for those made in the ordinary manner. (For defects of ordinary Compass, see Surveyor's Compass.)

- |   |                |
|---|----------------|
| <b>20. Surveying Compass, 16 inch plate, 6 inch magnetic needle. Two straight (ground) levels, outkeeper for keeping tally in chaining; sights graduated for the purpose of taking levels, or angles of elevation or depression; Ball and socket for Jacob Staff mounting; Cover to glass, and the whole instrument packed in mahogany box.....</b> | <b>\$56.00</b> |
| <b>21. Same instrument as No. 20, but with an extra Nonius plate, reading to single minutes of arc, for adding or subtracting the magnetic variation.....</b>   | <b>66.00</b>   |
| <b>22. Same instrument as No. 20, but with 15 inch plate and 5½ inch magnetic needle.....</b>   | <b>52.00</b>   |
| <b>23. Same instrument as No. 22, but with the extra nonius plate for the magnetic variation.....</b>   | <b>62.00</b>   |
| <b>Light Tripod head and legs to fit any of the above compasses.....</b>  | <b>9.25</b>    |
| <b>Light Tripod similar to the ones furnished with the Engineer's Transit or Level (see cut), combining the ball and socket for approximately rapid levelling, and the four vertical levelling screws for the precise levelling of the instrument;—Clamp to the centre.....</b>   | <b>18.00</b>   |
| <b>24. Pocket Surveying Compass, 2½ inch needle (sensitive) folding sights, cover to dial and packed in morocco box.....</b>  | <b>16.00</b>   |
| <b>25. Similar to No 24, but with ball and socket for Jacob Staff mountings.</b>  | <b>19.00</b>   |

The metal of which all these Compasses are made is very dense and hard, and not the ordinary hammered yellow brass.

Extra large size Transits, such as are used by the U. S. Coast Survey, with horizontal limbs of from one to three feet diameter, and reading by microscopes to seconds of arc, and furnished with powerful Telescopes, or for Astronomical Transits—price list will be furnished on application.

**EXTRAS.**

- |  |       |
|--|-------|
| Needle and cap.....  | 5.00  |
| Centre-pin.....  | 1.00  |
| Compass glass.....   | 1.00  |
| Magnifier for graduations.....                               | 1.00  |
| Camel's hair brush (for glasses).....                        | .50   |
| Buckskin " ".....  | .25   |
| Variation plate to either "Plain" or "Complete Transit"..... | 20.00 |
| Rod level (for plumbing rod or pole).....                    | 5.00  |

**PRICE LIST.**

**SURVEYOR'S AND ENGINEER'S CHAINS.**

Surveyor's Chain, 2 poles, 50 links, No. 9, wire oval rings.....	\$2.00
"        2    "    40    "    8,    "    .....	2.75
"        2    "    50    "    8,    "    .....	2.75
"        2    "    50    "    7,    "    .....	3.75
"        4    "    100   "    9, wire round rings.....	3.50
"        4    "    100   "    8, wire oval rings.....	4.50
"        4    "    100   "    7,    "    .....	5.50
"        4    "    100   "    12, best steel wire, brazed links and rings.....	10.00
"        2    "    50    "    12, best steel wire, brazed links and rings.....	5.50
Engineer's Chain, 50 feet, 50 "    7, wire.....	4.00
"        100   "    100   "    7, "    .....	6.00
"        50    "    50    "    12, best steel wire, brazed links and rings.....	6.00
"        100   "    100   "    12, best steel wire, brazed links and rings.....	11.50

**CHESTERMAN'S STEEL TAPE MEASURES.**

These steel Tapes we always test with the true United States standard, and give the purchaser a note of the comparison and the state of the thermometer at the time of testing. (See straight line measurements.)

Steel Tape Measures; all steel, to wind up in a box, same as linen measures.	
Steel Tape Measure, 10 feet long, in 10ths or 12ths, in German Silver case, each.....	\$3.25
Steel Tape Measure, 10 feet long, tape divided on one side to 12ths, and on the other to centimeters and millimeters.....	3.50
Steel Tape Measure, 25 feet long, in 10ths or 12ths, each.....	5.00
"        "        33    "    "    "    "    .....	5.75
"        "        40    "    "    "    "    .....	7.00
"        "        50    "    "    "    "    .....	8.50
"        "        66    "    "    "    "    .....	9.00
"        "        75    "    "    "    "    .....	11.00
"        "        100   "    "    "    "    .....	14.00
Steel Tape Measure, 3 feet long, in German Silver case, with spring and stop, tape divided into 10ths or 12ths of a foot.....	1.50
Steel Tape Measure, 4 feet long, in German Silver case, with spring and stop, tape divided into 10ths or 12ths of a foot.....	2.00
Steel Tape Measure, 5 feet long, in German Silver case, with spring and stop, tape divided into 10ths or 12ths of a foot.....	2.25
Steel Tape Measure, 6 feet long, in German Silver case, with spring and stop, tape divided into 10ths or 12ths of a foot.....	2.50
Steel Tape Measure, 3 feet long, tape divided on one side to 12ths of a foot, and the other side to centimeters and millimeters.....	1.75
Steel Tape Measure, 4 feet long, tape divided on one side to 12ths of a foot, and the other side to centimeters and millimeters.....	2.25
Steel Tape Measure, 5 feet long, tape divided on one side to 12ths of a foot, and the other side to centimeter and millimeters.....	2.50
Steel Tape Measure, 6 feet long, tape divided on one side to 12ths of a foot, and the other side to centimeters and millimeters.....	2.75

**CHESTERMAN'S METALLIC TAPE MEASURE.**

Metallc Tape Measure, 24 feet long, in 10ths or 12ths, each.....	\$1.80
"        "        33    "    "    "    "    .....	2.10
"        "        40    "    "    "    "    .....	2.60
"        "        50    "    "    "    "    .....	2.50
"        "        66    "    "    "    "    .....	3.00
"        "        70    "    "    "    "    .....	3.25



**PRICE LIST.**

Drawing Pen, 4 $\frac{1}{2}$ inches long, with joints.....	\$1.25
“ 5 $\frac{1}{2}$ “ “ “ .....	1.40
“ 6 $\frac{1}{2}$ “ “ “ .....	1.60
Round, or Double Drawing Pen.....	3.75
“ “ “ with joint in each side.....	3.00
Dotting Pen, with one wheel.....	2.00
“ with six wheels.....	3.50
Horn Centre, with German Silver edges.....	40
German Silver Centre, with handle.....	60
“ Fastening Tacks, per dozen.....	60
Steel Fastening Tacks, per dozen.....	75
Irregular Curves of Horn, each.....	75
Rolling Parallel Rule, ebony.....	3.00
Eccentric Rule, 11 inches long.....	2.00

Parties wanting cases made up of these Instruments can select the pieces, by the above list, that are best adapted to their purpose, and we will have boxes made to suit, at an additional cost of from \$7 to \$15, according to the size of the boxes, which are made of rosewood, mahogany or walnut, highly finished.

**PAPER PROTRACTORS.**

Whole Circle Protractor, 13 inches diameter, half degrees, on drawing paper, each.....	30
Whole Circle Protractor, 13 inches diameter, half degrees, on Bristol boards, each.....	40
Half Circle Protractor, 5 inches diameter, half degrees, on Bristol boards, each.....	25

**FRENCH TRACING PAPER.**

FINE QUALITY, VERY CLEAR AND STRONG.

In Sheets. Royal, 19x25 inches.....per quire,	\$1.00
“ Super-Royal, 21x26 inches.....“	1.50
“ Double Elephant, 28x40 inches.....“	2.00
In Rolls, 20 yards long and 42 inches wide,.....per roll,	2.00
“ 20 “ 40 “ .....	3.50
Vegetable Royal, 19x25 inches, per quire \$2.00, per sheet.....	15
“ Super Royal, 21x26 “ “ 2.50, “ .....	40
“ Double Elephant, 28x40 “ “ 10.00, “ .....	65
“ in rolls of 22 yards, 54 inches wide, per roll.....	5.00

**CONTINUOUS OR ROLL PROFILE PAPER, IN CONTINUOUS ROLLS OF ANY LENGTH.**

Plate A.—Rulings 22 inches wide, Horizontal Divisions, four to the inch ; Vertical Divisions, twenty to the inch, and having every tenth horizontal division line and every fiftieth vertical division line heavier than the others. Price, per yard.....	35
Plate B.—Rulings 22 inches wide, Horizontal Divisions, four to the inch ; Vertical Divisions, thirty to the inch, and having every fourth horizontal division line and every twenty-fifth vertical division line heavier than the others. Price, per yard.....	30
Plate C.—Rulings 9 inches wide, Horizontal Divisions, four to the inch ; Vertical Divisions, thirty to the inch, and having every fourth horizontal division line and every twenty-fifth vertical division line heavier than the others. Price, per yard.....	20





**PRICE LIST.**

**DRAWING STATIONERY.**

**WHATMAN'S HOT AND COLD-PRESSED DRAWING PAPERS, SELECTED.**

		Best.	2d qual
Demy,	20x15 inches.....per quire,	\$1.00.....	\$0.85
Medium,	22x17 "....."	1.50.....	1.25
Royal,	24x19 "....."	2.00.....	1.60
Super-royal,	27x19 "....."	2.50.....	2.00
Imperial,	30x21 "....."	3.50.....	3.00
Atlas,	33x26 "....."	5.25.....	4.50
Double Elephant,	40x26 "....."	6.00.....	5.75
Antiquarian,	52x31 "....."	30.00.....	18.00

Whatman's papers, hot pressed, have smooth surfaces; cold pressed, have fine-grain surfaces. Best and second quality of Whatman's papers are made of the same materials; the best is free from spots and imperfections.

**CONTINUOUS DRAWING PAPER. EXTRA WHITE.**

IN ROLLS OF 30 TO 50 POUNDS.

German make, 36 inches wide,	per pound \$0.35, per yard.....	20
" 36 " thin superior,	" 45 " .....	33
" 42 " thick,	" 40 " .....	30
" 42 " " superior,	" 45 " .....	36
" 42 " thin,	" 35 " .....	24
" 54 " thick,	" 45 " .....	50
" 54 " thin,	" 45 " .....	35
Best egg shell, 59 " thick,	" 45 " .....	65
" " 59 " medium,	" 45 " .....	47
" " 59 " thin,	" 45 " .....	42

**MUSLIN BACKED CONTINUOUS DRAWING PAPER. EXTRA WHITE.**

IN ROLLS OF 10 YARDS.

Best German Paper, 42 inches wide, per roll	\$8.85, per yard.....	\$1.00
" " 54 " " 11.75 " .....		1.40
" " 59 " " 13.00 " .....		1.60

**CONTINUOUS DRAWING PAPER, BUFF TINT, FOR WORKING DRAWINGS.**

BEST ENGLISH MAKE, IN ROLLS OF 30 TO 40 POUNDS.

36 inches wide, medium thickness, per pound \$0.25, per yard..	15
56 " " " 25 " .....	25

BEST AMERICAN MAKE, IN ROLLS OF 70 TO 100 POUNDS.

30 inches wide, thick, per pound \$0.12, per yard.....	10
42 " " " 12 " .....	16
48 " " " 12 " .....	18
54 " " " 12 " .....	20

*Full rolls only of continuous paper sold by the pound at above rates.*

**TRACING OR VELLUM CLOTH.**

In Rolls of 24 yards, both sides glazed, or face glazed and back dull, suitable for pencil marks.

Imperial, 18 inches wide, per roll \$5.00, per yard .....	25
" 30 " " 6.90, " .....	30
" 36 " " 7.60, " .....	40
" 42 " " 10.50, " .....	60
Sagar's Patent, 18 " " 5.00, " .....	25
" 30 " " 7.50, " .....	35
" 36 " " 8.50, " .....	45
" 42 " " 11.00, " .....	65



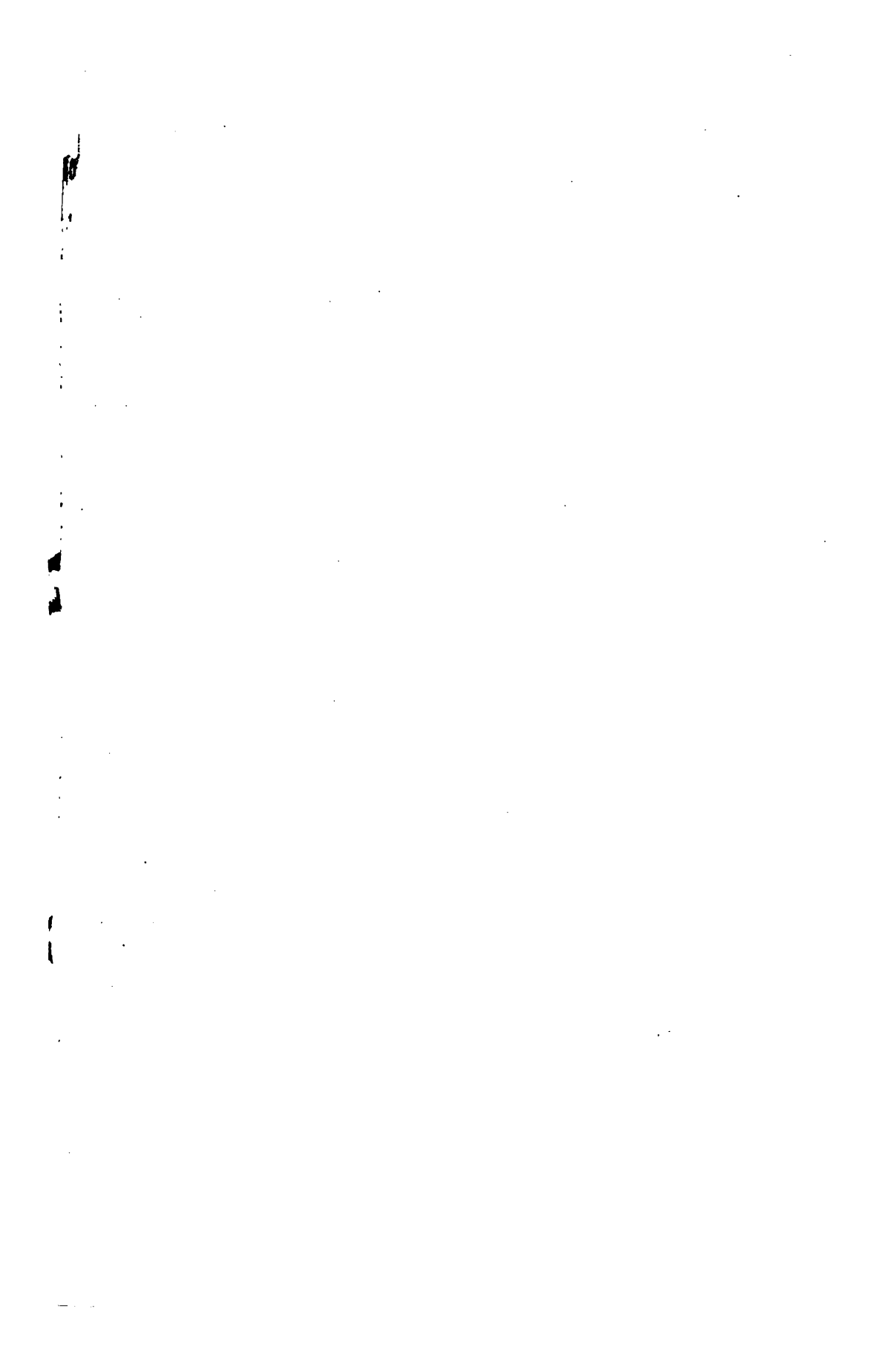

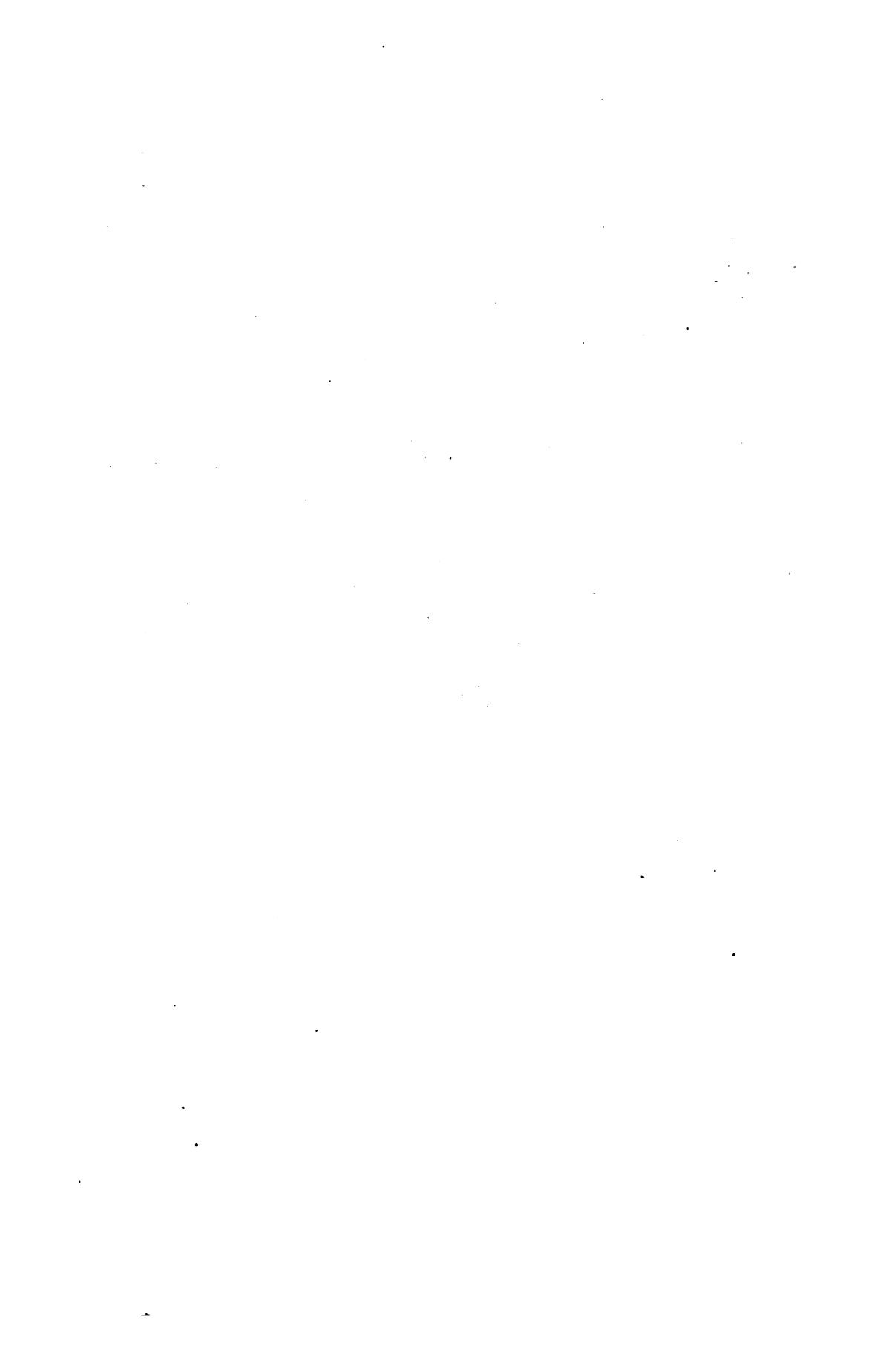

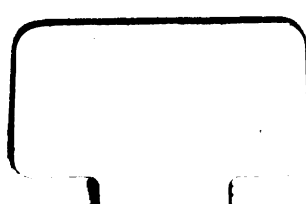

Eng 535.18  
Remarks on engineers' surveying ins  
Cabot Science 005225476



3 2044 092 010 230